



**Contributions to the
conference in Copenhagen
19-23 November 2007**

MUSEUM MICROCLIMATES

Contributions to the Copenhagen conference

19 - 23 November 2007

Museum Microclimates

Edited by Tim Padfield and Karen Borchersen

Scientific Committee
Mads Christian Christensen
Bent Eshøj
Tim Padfield
Morten Ryhl-Svendsen
David Thickett

Published by
The National Museum of Denmark

ACKNOWLEDGEMENTS

The conference was a collaboration between:

The National Museum of Denmark

The Conservation Centre, Vejle

The School of Conservation of the Royal Danish Academy of Fine Arts

The working group Preventive Conservation

of the International Council of Museums Conservation Committee

We thank The Heritage Agency of Denmark (KUAS) for support.

The information and opinions set out in this volume are the responsibility of the individual authors.

Copyright: This publication is issued with a Creative Commons Attribution - Noncommercial - No Derivative Works 3.0 Licence.

You may freely copy articles from this volume but the authors must be acknowledged, no changes may be made and you may not sell any part of this work.

The digital version of this volume is at:
microclimates.natmus.dk

Cover design by Anne Marie Brammer and photographs by Cille Krause.

The paper version is printed by
LP Nielsen Bogtryk, Hvidovre

ISBN 978-87-7602-080-4

The articles collected in this volume give a snapshot of current opinion and research in the preservation of artifacts through manipulation of their environment. There is little about exotic environments such as oxygen free enclosure or cold storage but abundant advice and information about reducing fluctuations of temperature and relative humidity in spaces that are within the environment for human comfort but not in accord with current standards for the museum environment.

Several authors concentrate on buffering the microclimates in small enclosures, to make the relative humidity, at least, independent of the ambient air [Thickett 245, Shiner 267, Watts 253, Toledo 261, Hackney 229]. It is far more difficult to prevent heat exchange with showcases so there are several articles about the influence of temperature change and temperature gradient on the atmosphere within small enclosures [Richard 237] and its consequences [Ligterink 27, Mecklenburg 19].

Calming the unruly climate of historic buildings is a challenge that is being met in several ways. One author [Larsen 167] presents case histories of architectural modifications, such as glass partitions, as a practical way of reconciling public comfort with preservation of salt contaminated wall paintings. A detailed examination of the climate in a private house museum describes it as acceptable though not ideal [Maekawa 99]. A more systematic and abstract attempt to define the allowable climate fluctuations in historic buildings [Bratasz 129] asserts that future fluctuations in a particular building should be limited to less than past fluctuations by a statistically defined amount, in preference to imposing a standardised climate specification that takes no account of the past climate in that particular building. In one extreme case, the authors advocate making an open pavilion into a closed room to reduce winter damage [Lithgow 175].

The strain of ameliorating the damage done by a bad climate is particularly evident in the tropics. Passive enclosure is surprisingly effective in reducing the extremes of relative humidity which vastly accelerate biological activity [Toledo 261]. Simple measures to ventilate during naturally dry periods of the day can also help to reduce damage [Broecke 213].

Scepticism over the validity of strict universal standards is evident in many contributions [Erhardt 11, Ntanos 91, Padfield/Larsen 191, Bratasz 129]. Risk analysis is hailed as the better way to decide what needs to be done urgently to preserve artifacts in a particular environment [Fry 107, Brokerhof 115]. Risk analysis depends on an accurate description of the connection between the environment and the deterioration of artifacts. There is still rather little scientifically exact and quantitative data about this. One article compares the preservative effect on paper of deacidification and of cooling [Balažic 39]. There is also an attempt directly to measure the deterioration of some of the materials of historic artifacts by plating them on quartz crystals and measuring weight change on exposure, as revealed by vibration frequency change [Odlyha 73]. Egg tempera paint is multi-sensitive to environmental influences but lead is fairly specifically sensitive to organic acids [Costa 63].

Enclosure of artifacts in showcases and frames reduces access to air pollutants and dust, while allowing the accumulation of corrosive gases from the materials of the interior of the enclosure and the enclosed artifacts [Ryhl-Svendsen 221]. There are contributions to the analysis of atmospheric pollution, and there is a considerable interest in dust, its composition and its pattern of deposition, particularly in environments where enclosure is not practical, such as in historic house libraries [Lloyd 135].

There are two articles about techniques for measuring air quality [Costa 63, Schieweck 67]. There are contributions about how to use these measurements to define the aggressiveness of the environment [Reilly 123]. An infra red technique is described which promises to give a good indication of the state of preservation of paper [Strlič 81] but until parallel environmental measurements have been made one cannot correlate environmental parameters with measured damage.

One of the matters curiously absent from the risk analysis articles is the risk that the environmental records that underpin risk analysis fail to survive in the digital age of rapid obsolescence of computer programs and storage formats and the uncertain durability of storage materials [Padfield 157].

Another matter that risk analysers seem to accept as beyond their power to influence is the architecture of the museum. In the Royal Ontario Museum many showcases have piped air to isolate them from the exhibition room relative humidity [Coxon 277], even in the newest extension to the museum. The physics of designing for a naturally good climate without air conditioning is laid out in one article [Padfield/Larsen 191] and the experience of using a purpose built store is described in another [Rasmussen 207]. Windows are a source of glare and of uncontrolled light but they also provide the most energy efficient lighting and can greatly reduce heating caused by artificial lighting [Huber 199].

Remarkably, photochemical deterioration attracts very little research nowadays. In this volume there is only one review article about museum lighting [Druzik 51]. The biological articles are limited to a review of the effect of temperature and relative

humidity on the life of insects [Child 57] and a calculation method for assessing the risk of mould growth within the outer walls of buildings [Krus 185].

To summarise this volume, there is much about making artificial microenvironments, mainly to control relative humidity. The economic advantages of using risk analysis to put climate control in its proper place among the agents of destruction continues to be a focus of attention. The lack of scientific evidence of decay rates to back up stringent environmental standards continues to embarrass the preventive conservator. The disregard for microclimate shown by museum architects continues to be accepted humbly by conservators, in spite of evidence that pleasant buildings can be constructed with far greater natural stability in climate than is shown by the current crop of dramatically sculptural museum buildings.

TABLE OF CONTENTS

Introduction Tim Padfield	3
-------------------------------------	---

SESSION 1

THE EFFECT OF THE ENVIRONMENT ON ARTEFACTS

Applying science to the question of museum climate David Erhardt, Charles S. Tumosa and Marion F. Mecklenburg	11
Micro climates and moisture induced damage to paintings Marion F. Mecklenburg	19
Canvas paintings on cold walls: relative humidity differences near the stretcher. Frank J. Ligterink and Giovanna Di Pietro	27
Extending the useful life of paper - evaluation of the effect of various preservation actions Aneta Balažic, Špela Habicht, Mateja Smodiš, Jana Kolar and Matija Strlič	39
Warm feet and cold art: is this the solution? Polychrome wooden ecclesiastical art - climate and dimensional changes Tone M. Olstad and Annika Haugen	43
Museum lighting: its past and future development James Druzik and Bent Eshøj	51
Insect damage as a function of climate Robert E. Child	57

SESSION 2

MEASURING THE ENVIRONMENT

Impact of the environmental conditions on the conservation of metal artifacts: an evaluation using electrochemical techniques Virginia Costa and M. Dubus	63
Screening emission analysis of construction materials and evaluation of airborne pollutants in newly constructed display cases A. Schieweck, D. Markewitz and T. Salthammer	67
Dosimeters for indoor microclimate monitoring for cultural heritage M. Odlyha, C. Theodorakopoulos, D. Thickett, M. Ryhl-Svendsen, J.M. Slater and R. Campana	73
The SurveNIR project- a dedicated near infra red instrument for paper characterization Matija Strlič, Jana Kolar and Dirk Lichtblau	81
Determination of response rates of wooden objects to fluctuating relative humidity in historic properties Barry Knight and David Thickett	85

SESSION 3

USING KNOWLEDGE OF THE EFFECTS OF CLIMATE: SURVEYING ACTUAL COLLECTIONS

A holistic appraisal of environmental conditions in the National Archives, UK	91
Kostas Ntanos and Nancy Bell	
Investigation into impacts of large numbers of visitors on the collection environment at Our Lord in the Attic	99
Shin Maekawa, Bart Ankersmit, Edgar Neuhaus, Henk Schellen, Vincent Beltran and Foekje Boersma	
What's causing the damage! The use of a combined solution-based risk assessment and condition audit	107
Claire Fry, Amber Xavier-Rowe, Frances Halahan and Jennifer Dinsmore	
Applying the outcome of climate research in collection risk management	115
Agnes W. Brokerhof	
Documenting and optimizing storage conditions at the National Museum of Denmark	123
James M. Reilly, Jesper Stub Johnsen and Lars Aasbjerg Jensen	
Target microclimate for preservation derived from past indoor conditions	129
Łukasz Bratasz, Dario Camuffo and Roman Kozłowski	
Dust in historic libraries	135
Helen Lloyd, Caroline Bendix, Peter Brimblecombe and David Thickett	
Libraries and archives in historic buildings	145
David Thickett, Soek-Joo Rhee and Sarah Lambarth	
Why keep climate records - and how to keep them	157
Tim Padfield	

SESSION 4

USE OF ENCLOSURE TO CONTROL CLIMATE - THE LARGER ENVIRONMENT

Climate control in Danish churches	167
Poul Klenz Larsen	
Managing external environments through preventive conservation: the investigation and control of environmentally-caused deterioration of decorative surfaces in the Marlborough Pavilion, Chartwell, Kent	175
Katy Lithgow, Tobit Curteis and Linda Bullock	
Mould growth prediction by computational simulation on historic buildings	185
M. Krus, R. Kilian and K. Sedlbauer	
The potential and limits for passive air conditioning of museums, stores and archives	191
Tim Padfield, Poul Klenz Larsen, Lars Aasbjerg Jensen and Morten Ryhl-Svendsen	
Problem-zone "Window"	199
Alfons Huber	

Evaluation of the climate in a new shared storage facility using passive climate control Michael Højlund Rasmussen	207
Sustainable passive climate control in developing countries: a case study at the National Museum of Art in Maputo, Mozambique Lara Broecke	213
The role of air exchange rate and surface reaction rates on the air quality in museum storage buildings Morten Ryhl-Svendsen	221

SESSION 5

THE SHOWCASE AND THE PICTURE FRAME

The evolution of a conservation framing policy at Tate Stephen Hackney	229
The benefits and disadvantages of adding silica gel to microclimate packages for panel paintings Mervin Richard	237
The effect of air tightness on rh buffering and control David Thickett, Phillip Fletcher, Andrew Calver and Sarah Lambarth	245
Museum showcases: specification and reality, costs and benefits Siobhan Watts, David Crombie, Sonia Jones and Sally Ann Yates	253
The use of glass boxes to protect modern paintings in warm humid museums Franciza Toledo, Magali Sehn, Mário Sousa Júnior, Sérgio Brazolin and Stephen Hackney	261
Trends in microclimate control of museum display cases Jerry Shiner	267
The good, the bad and the frustrating: designing and implementing a climate control system at the Royal Ontario Museum Helen Coxon	277

Session 1

The effect of the environment on artefacts

APPLYING SCIENCE TO THE QUESTION OF MUSEUM CLIMATE

DAVID ERHARDT, CHARLES S. TUMOSA AND MARION F. MECKLENBURG

ABSTRACT

An examination of the history and development of recommendations for the climate in museums reveals that there was minimal scientific support for the values and ranges that were selected. The small basis of research that existed was often extended to materials or objects to which it did not apply; decisions that were merely best guesses based on minimal evidence became set in stone; and the rationale for many decisions seems to have been forgotten or twisted around. Many recommendations were based on considerations other than permanence of the objects, such as mechanical limitations of HVAC systems, constraints imposed by the exterior climate or historic building regulations, or costs of implementation and maintenance. It is only relatively recently that research has provided a general scientific basis for determining appropriate values for the museum climate, especially the range in which temperature and relative humidity can be safely allowed to vary. Because the results of this research differed from what had become climatic dogma, it was criticized by some in the field. However, the results have stood up, with no substantive challenge to the data or conclusions, and are increasingly widely accepted.

THE NEED FOR ENVIRONMENTAL CONTROL IN MUSEUMS

The preservation of collections depends upon knowing how the materials and objects in the collection behave and how the environmental influences acting on them can be controlled to maximize their lifespan and chance of survival. Some aspects of preservation are obvious: fire, flood, pollution and earthquakes will damage or destroy most collections. It is obvious that such threats should be controlled, eliminated or minimized to the extent possible. Damage due to light and inappropriate values or ranges of temperature and relative humidity (RH) is often much slower and less dramatic, but nonetheless is also a serious problem. Light cannot simply be eliminated, since light is required to view objects and allow people to move about safely. The amount and type of radiation to which susceptible collections are exposed should be limited to the minimum amount and spectral range of visible light required to view an object. This is

difficult to put into practice because of the variability in human vision, and the wide ranges of colour, contrast, and texture of objects, as well as sources of light. The determination of appropriate ranges of temperature and relative humidity (RH) is infinitely more complex still. Many more types of effects have to be considered since different materials may have quite different responses to specific values of, or changes in, temperature and RH. Climates that are appropriate for one type of material or object may be damaging for others. Both short term effects and long term aging processes must be taken into account. The maintenance of specific museum climates in general is an active, expensive, and time-consuming responsibility. An appropriate climate will contribute to the permanence of a collection, but maintaining a climate chosen on the basis of incorrect or incomplete information may be both damaging and wasteful of money and energy. This paper will examine the history of the museum environment, the ways in which museum climates have been chosen, the development of knowledge of how and why objects deteriorate, and how the present body of knowledge is being used in the determination of appropriate environments.

THE DEVELOPMENT OF MUSEUM CLIMATE SPECIFICATIONS

Objects originally were exposed to the same climate as humans. Aside from limited heating from fireplaces, it was neither technologically nor economically feasible to control the interior climate or do much more than store valuable objects in boxes or cases. The advent of industrial technology, central heating, and eventually air conditioning and humidity control made it possible to modify or produce interior environments that were either more uniform than, or different from, the exterior. Central heating without humidification, for example, was able to produce relative humidities lower than would have previously been experienced in interior living spaces. Extremely low RH can cause problems including the flaking of paintings, cracking and warping of wood, and loosening of furniture joints. While water washing of airflow systems was originally developed to remove dust and pollutants, it was recognized that it could also be used to control the RH and reduce problems associated with unhumidified central heating. The Boston Museum of Fine Arts installed

a central heating, air washing, and humidification system in 1908, and after 2 years “found that the humidity best adapted for paintings and other works of art ranged from 55 to 60 percent” [1]. McCabe provided no information on any tests or results that led to this range, but the statement was highly influential in the development of environmental control in museums. The range appears frequently in subsequent recommendations, usually with no specifics as to how it was derived. Recommended temperatures varied, but were generally lower than would be considered today, and were often determined by the capacity of the heating systems. Then as now, though, any temperature recommended for the general museum climate had to be within the human comfort zone. The development of improved air conditioning systems led to its installation in a dozen museums in the US by 1941, including the National Archives and the Library of Congress [2].

The next major development occurred during World War II. During the war, the collections of the National Gallery in London were moved to caves in slate quarries in Wales. The natural conditions in the caves were cool and constant, but close to 100% RH. Such a high RH would have resulted in damage (mould, if nothing else), so simple heating was used to lower the RH. The target value chosen was 58%- the average RH in the National Gallery, as determined earlier by monitoring the weight of blocks of wood left for several months in the Gallery. Their average weight corresponded to the equilibrium moisture content at 55-60% RH [3]. The observation that flaking of the paintings stopped during storage in the constant environment of the caves was the primary impetus for the installation of air conditioning in the Gallery after the war. Interestingly, the specific RH chosen at the time for paintings (and, indeed, other objects in the collection as well as the library) was based on measurements of blocks of wood in the average RH in London, not on any research indicating that paintings were most stable or permanent under the chosen conditions. The conditions simply replicated the average RH in London, without the variations. In the absence of data to recommend any other climate, replicating the Gallery climate was less risky than choosing different conditions. However, there was nothing to show that these specific conditions or such narrow ranges were required or optimal, or that other conditions could not have been as, or more effective in reducing damage. The only real conclusion that could be drawn was that the quarry conditions were much better than the uncontrolled, greatly variable conditions of the un-airconditioned Gallery before the war. In part because of these results, the value

of climate control in museums rapidly gained acceptance, and was often implemented using similar values. In 1960, the results of a survey of museums indicated a preferred range of RH values ranging from 40% to 70% RH, most within or overlapping the 50-60% range [4]. In the article, Plenderleith advocates a “zone of safety” of 50 to 60% RH, with 50% the lower limit to avoid dangerous desiccation (such as the supposed embrittlement of parchment) and 60% the upper limit to avoid mould growth. Plenderleith previously had used data on the seasoning of timber to argue for the 50% lower limit [5]. Again, little real data (such as data on the RH dependence of the stiffness of parchment) is presented to justify the various values in the survey or elsewhere. Even the statements that were made, such as those assuming embrittlement of organic materials below 50% RH, often had no basis in experiment. Practicality is evident in some cases. It is difficult and expensive to maintain high RH in winter in cold climates, and even if it can be achieved, condensation in the roof and exterior walls can cause serious damage to the building. Lower values of RH (as low as 25% in winter) eventually were adopted in the northern US and Canada, not because they were shown to be safe for collections, but because maintaining higher values in winter was difficult or impossible. This relates to the common belief that values other than the usual ones are OK if objects are “used to it”, again with little real justification. (It should be noted here that most of the discussion relating to appropriate RH focuses on organic materials, since appropriate values of RH for inorganic materials are better defined and less controversial. There are some exceptions, such as weeping glass and ceramics containing deliquescent salts, for which appropriate environments are yet to be determined.)

The culmination of this process was the publication of *The Museum Environment* [6] by Garry Thomson of the Scientific Department of the National Gallery, London. To a greater extent than any previous publication, *The Museum Environment* examined the available scientific evidence and made an attempt to derive appropriate values and allowable ranges, rather than simply draw conclusions based on vague, unsupported, or questionable statements. Thomson, evidently more than anyone else, was aware of the lack of relevant knowledge, and qualifies many of his statements. While he does recommend taking into account the type of collection and local climate when determining what conditions to maintain, his recommendation for typical museums was 55% RH. The value of 55% RH was chosen to a great extent because it is the midpoint of what he considered a safety zone between 40%

RH (embrittlement) and 70% RH (mould growth), rather than because of any evidence indicating that 55% RH is an optimal value. (Later research by the present authors showed that the common perception that organic materials embrittle below 40% RH has little basis in fact). There was plenty of evidence that extremes of relative humidity cause damage, but little to indicate how much the climate could be allowed to vary without causing damage. Thomson suspected that there was a threshold variation below which damage did not occur, but not enough information to determine what the threshold range was. He qualifies his recommendations by stating quite explicitly: “The tolerance usually quoted of ± 4 or 5% RH is based more on what can be expected of an air-conditioning plant than on what exhibits can actually stand without deterioration, which is not known in any detail.” In other words, RH control was based on what was possible, not what was required, simply because at the time it was not known how closely the RH had to be controlled to eliminate damage. The threshold limit of fluctuation below which damage did not occur had not been determined, so the least risky course (at least in terms of the safety of the objects) was to control the RH as tightly as possible. An obvious implication is that when information regarding allowable fluctuations becomes available, these values should be reconsidered. Unfortunately, Thomson’s book seems to have been quoted (or misquoted) more often than it has been read or understood. When asked why the RH has to be maintained within ± 4 or 5% RH, a typical response is that *The Museum Environment* says that is what is required to keep the objects from falling apart.

Thus, while there had certainly been serious attempts to determine the effects of climate on museum objects, the climate specifications typically used in museums for temperature, RH, and allowable RH fluctuation ultimately seem to derive from three basic bits of data—the human temperature comfort zone; the average RH in the National Gallery, London, as determined by weighing blocks of wood; and the practical mechanical limitations on RH control in museums. The climate recommendations thus “derived” have since been extended, solidified, and modified with little more justification. The temperature values are probably the least controversial, since for practical reasons general exhibit spaces must be maintained within the human comfort range regardless of any effect on permanence. Storage is a different matter, and beyond the scope of this article. There is little evidence that 55% RH is optimal for blocks of wood, and no more evidence for the extension of this value to paint, paper, parchment, textiles, photographs, bone, etc. As Thomson stated, his specified variations

of $\pm 4\%$ or 5% RH were determined by mechanical limitations. Predictably, the incorrect interpretation “more constant is better” has led to the philosophy that if $\pm 5\%$ is good, then $\pm 2\%$ is better— or at least it won’t hurt. Never mind that maintaining such narrow ranges is expensive and impractical if not impossible, and standard methods of measurement of RH have uncertainties greater than the specified ranges [7].

REQUIREMENTS FOR CONTROL OF THE MUSEUM CLIMATE

There are three fundamental steps in controlling the museum climate:

1. Determine the effects of the environment on materials and objects.
2. Set specifications based on the results of Step 1, taking into account the type of collection, the building and the local climate and economics.
3. Maintain and monitor the environment based on the results of Step 2.

Unfortunately, there has been a lot more effort put into Steps 2 and 3 than Step 1. Thomson acknowledged as much when he said “...we have to erect this framework of preventive conservation before rather than after our research has reached a dignified level of completion.” [6]. Specifying climate control requirements and telling the engineers to implement them is easier by orders of magnitude than the research required to justify the specifications. Monitoring the environment is also straightforward, and with modern sensors, data logging equipment and computer processing has become routine. The hard part of Step 3 is the implementation of climate specifications. This is especially true when they are too strict, ignore factors such as local climate, can potentially damage the building, or their implementation is too expensive in terms of equipment, personnel, energy, repair and maintenance.

One of the first indications that physical damage to museum objects due to environmental effects might be quantifiable and predictable was a paper presented at the 1982 meeting of the IIC. In it, the engineering concept of finite element analysis (FEA) was shown to be applicable to the complex layered structures of paintings, and to predict patterns of damage that matched observed damage [8]. One of the authors, Marion Mecklenburg, later joined the Conservation Analytical Laboratory (CAL, later SCMRE, at present MCI) of the Smithsonian Institution,

where complementary environmental research was proceeding.

The first indication that research was being conducted at the CAL that could lead to rational and justified specifications for the museum climate was a lecture presented at a national meeting of the American Chemical Society [9]. In this presentation, the effects of specific environments, as well as changes in environments, on different types of materials of museum objects were discussed. Topics included changes in reaction rates, critical values of RH, and changes in dimension and physical and mechanical properties for various types of materials. The critical remaining problem, though, was the determination of allowable limits of variation in the environment. Other papers followed, expanding on the theme of determining environmental effects on the chemical, physical, and mechanical properties of the materials of museum objects, and applying this data to predict the behavior of complex objects [10-16]. Research was conducted on the effect of temperature and relative humidity on important degradation processes, and tests conducted to determine the physical response of a wide variety of materials to changes in temperature and relative humidity. The effects of aging processes (chemical reactions) on physical properties and responses were also examined. Extensive experimentation showed that tensile tests and dimensional temperature and moisture isotherms were related to the changes in restrained materials subject to changes in temperature and RH (the museum path), and could be used in predictive modeling using FEA [17]. In other words, measurements of the dimensional response of individual materials to environmental changes can be combined with the results of standard mechanical testing to predict stresses and strains induced in composite objects by environmental changes. Computer modeling approaches were developed that could take the data for individual materials and predict the behavior of composite objects. Most importantly, these models could predict when changes in a component of an object exceeded the elastic (reversible) limits. All materials can reversibly sustain some stress and strain, and it is only when these limits are exceeded that permanent change or damage such as warping or cracking occurs. Modeling showed how much change in climate was required to produce irreversible changes, and consequently how much change could be allowed without damage. Significantly, this approach predicted not just ultimate failure, but the onset of any irreversible physical change.

Within this allowable range of RH that does not produce short term physical damage, permanence

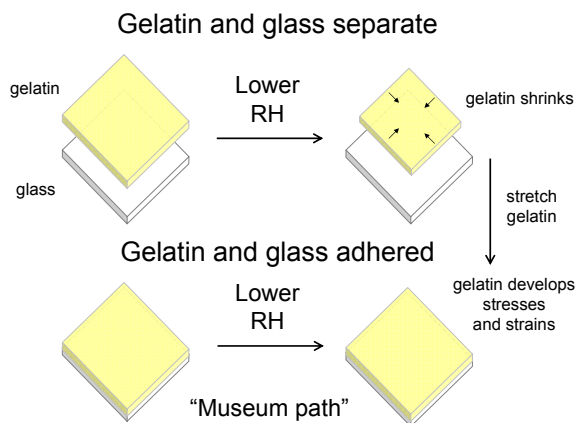

Figure 1. Extreme environmental changes cause damage due to the differential expansion and contraction of materials. If the RH around a free gelatin layer is lowered, it shrinks and no stresses or strains are generated. If it is adhered to a glass plate that does not respond to RH changes, however, it cannot shrink because the glass is stiffer, stronger, and thicker. Stresses and strains develop in the gelatin even though there is minimal dimensional change. The glass plate develops little strain (its size is minimally different from a free glass plate) but develops stresses equal and opposite to those in the gelatin layer. This example demonstrates why the stress-strain behaviour and dimensional response to RH change of the individual materials must be known to predict the behaviour of an object, and why dimensional measurements alone cannot be used to determine the state of an object or to predict behaviour.

can be optimized by choosing conditions (or more precisely, a range of conditions) that minimize long term processes and chemical reactions and that are feasible and economical to maintain. Within a range determined by minimizing physical damage, the climate can be adjusted seasonally to minimize expense, maintenance, and other problems, while still respecting the need to preserve the collection. For example, maintaining cooler and drier conditions during winter can offset the effects of slightly warmer and more humid conditions during summer (as long as these changes are kept within the overall safe range).

In 1994, a press release from the Smithsonian Institution announced that scientists at the CAL (Mecklenburg, Tumosa, Erhardt, and McCormick-Goodhart) had developed new guidelines for the museum climate based on their research [18]. Combining previous and ongoing environmental research with computer modeling, it became possible to predict irreversible changes (damage) due to fluctuations in the climate. The scientists were now able to develop rational guidelines that took into account environmental effects on chemical, physical and mechanical properties of materials. The primary advance was in being able to predict how much environmental fluctuation was required to force a component of an object beyond its

Equivalence of Laboratory and Museum Paths

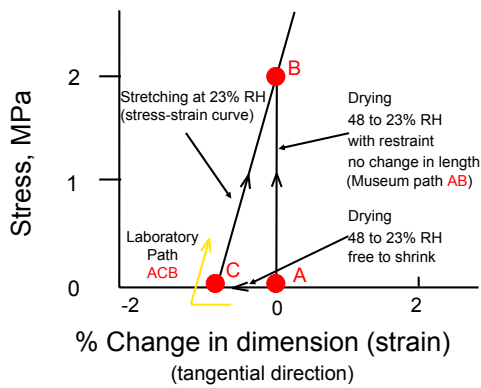

Figure 2. Point A represents a free material (such as wood) in an unstressed state. If the material is restrained while the RH is lowered, the dimension remains the same but stresses develop due to the force required to keep it from shrinking. The development of stress in moving from point A to point B is what can occur in a composite object exposed to RH fluctuations, the “museum path” AB. If the material is allowed to freely shrink during the RH change, no stresses develop in moving from point A to point C. If the material is then stretched to its original size (CB), it develops stresses equal to those generated in the restrained material. Dimensional change due to RH changes (AC) and stress-strain behaviour (CB) can be measured in the laboratory, and the laboratory path ACB used to predict the effects of RH changes in the museum. If the dimensional change CA during the stress strain measurement is within the elastic limit of the material, the process is reversible and there is no permanent change or damage.

elastic (reversible) limit, and therefore the range which did not produce irreversible changes (figures 1 and 2). Using worst case examples such as an RH responsive material adhered to a non-responsive material (e.g. gelatin on glass plate photographic negatives) that was allowed to fully respond to a possible change in RH or temperature, they could calculate conservative allowable ranges for general collections. In general, the allowable range for an object (or collection) is determined by the most responsive component material present. The guidelines provided safe ranges in which mechanical and physical damage was prevented and slower processes such as chemical deterioration could be minimized. Significantly, the results showed that moderate fluctuations within the range 50 +15% RH were safe. The results were published in a paper presented at a meeting of the International Institute for Conservation [19]. The reaction to this challenge to current dogma was immediate. Numerous critical letters and comments appeared, but these tended to have no more substance than what the previous specifications had been based on. There has been no substantive challenge to the basic data, interpretation, theory, or conclusions used to derive the guidelines. Subsequent papers have refined and expanded the guidelines and the science behind them [20-30].

The allowable fluctuation of temperature or RH varies with the starting setpoint, because the responsiveness of materials varies with temperature and RH. For general collections, variations within the range 30% to 60% RH are mechanically safe. The temperature is usually determined by human comfort considerations, but should be maintained above 13°C to stay above the temperatures at which some materials such as acrylics undergo phase transitions and become brittle. Within this range of mechanical safety, long term chemical stability is usually enhanced by cooler and drier conditions. There are exceptions to these recommendations. For example, photographs generally should be kept in cold storage. Metal objects should be kept in the dry end of the recommended range. Severely degraded materials, objects with weak or degraded adhesives (especially veneers and inlays), or objects such as drums and Japanese screens with pre-existing stresses should be kept in more stable environments. Display cases and storage cabinets alone or with buffering agents (which can be other hygroscopic objects) provide an extra degree of protection against RH fluctuations. Current environmental guidelines at the Smithsonian call for 45 ±8% RH and 70 ±4 F (approximately 21 ±2°C), values which are well within the already conservative generally allowable ranges.

RESULTS

The new guidelines are increasingly widely accepted, and have been adopted in a number of museums and institutions. Because the new guidelines are more flexible and allow a wider range of environmental conditions, implementing them is simpler, less expensive, and less time consuming. For example, the costs of construction of the Udvar-Hazy Center annex to the National Air and Space Museum of the Smithsonian Institution were reduced by approximately \$10,000,000 (10%) when the new guidelines were incorporated into the planning. Energy costs have also been reduced. Ongoing implementation of the new guidelines in Smithsonian museums resulted in cost savings of \$2.7 million in just the second half of 2006 (out of \$32 million total energy costs for all of 2006), and \$1.5 million in the first quarter of 2007. The savings were achieved because the building managers

“were able to run smaller or fewer boilers during summer, secure or setback air handling equipment during unoccupied periods, raise chilled water supply setpoints, lower heating water boiler supply setpoint, reduce boiler pressure, secure outside air

and exhaust during unoccupied periods, minimize OA intake, raise space temperature setpoints, raise AHU discharge temperatures, secure terminal reheat/fan-coils, secured reheat pumps, etc.” [31]

In addition to the cost savings, the new guidelines also help preserve the historic buildings of the Smithsonian Institution which are an integral component of the collections. There have been no reports of damage to the collections due to implementation of the new guidelines.

CONCLUSIONS

Early specifications for the museum climate were based on little evidence, illogical and unfounded interpretations of what evidence was available, and extensions to materials, objects and situations not covered even by the minimal evidence available. Nevertheless, the recommendations became fixed and inflexible. Eventually, research resulted in the development of more rational guidelines for the museum climate. While entrenched thinking (or lack of it) has persisted, the new guidelines have gained wide acceptance.

AUTHORS

David Erhardt
9323 Ocala Street, Silver Spring, MD 20901, USA
Phone: 301-562-4103
derhardt@hotmail.com

Charles S. Tumosa
University of Baltimore
Division of Criminology, Criminal Justice, and
Social Policy, Yale Gordon College of Liberal Arts
1420 North Charles Street, Baltimore, MD 21201-
5779
cstchemist@aol.com

Marion F. Mecklenburg
Senior Research Scientist
Smithsonian Institution, Museum Conservation
Institute
Museum Support Center, Room F 2013,
4210 Silver Hill Road, Suitland, MD 20746-2863
mecklenburgm@si.edu

REFERENCES

1 McCabe, J. ‘Humidification and ventilation in art museums’, *Museum News* (September 1, 1931), 7-8.

- 2 Review, ‘Air conditioning of museums’, *Refrigerating Engineering*, (August, 1935), 85, 105.
- 3 Keeley, T. and F. Rawlins, ‘Air conditioning at the National Gallery, London. Its influence upon the preservation and preservation of pictures’, *Museum (UNESCO, Paris)*, 4 (1951), 194-200.
- 4 Plenderleith, H. and P. Philpott, ‘Climatology and conservation in museums’, *Museum (UNESCO, Paris)*, 13 (1960), 202- 289.
- 5 Plenderleith, H. *Conservation of Antiquities and Works of Art: Treatment, Repair, and Restoration*, London, Oxford University Press (1956).
- 6 Thomson, G. *The Museum Environment*, 1st edition, Butterworths, London (1978).
- 7 Brown, J. ‘Hygrometric measurement in museums: calibration, accuracy, and the specification of relative humidity’, in A. Roy & P. Smith (ed.s), *Preventive Conservation: Practice, Theory and Research. Preprints of the Contributions to the Ottawa Congress*, International Institute for the Conservation of Artistic and Historic Works (IIC), London (1994), 39-43.
- 8 Colville, J., W. Kilpatrick & M. Mecklenburg, ‘A finite element analysis of multi-layered orthotropic membranes with applications to oil paintings on fabric’, in N. S. Brommelle and G. Thomson, eds., *Science and Technology in the Service of Conservation. Preprints of the Washington Congress*, International Institute for the Conservation of Artistic and Historic Works (IIC), London (1982), 150-156.
- 9 Erhardt, D., and M. Mecklenburg, ‘Relative Humidity and the Care of Museum Collections’, in *Abstracts of Papers: 198th ACS National Meeting*, American Chemical Society, Washington, 1989, ENVR 0092.
- 10 Mecklenburg, M. F., ‘Some Aspects of the Mechanical Behavior of Fabric Supported Paintings’, Report to the Smithsonian Institution, Research supported under the National Museum Act (1982).
- 11 Erhardt, D. ‘Relationship of Reaction Rates to Temperature’, *Abbey Newsletter* 13(3) (1989), 38-39.
- 12 Erhardt, D., ‘Paper Degradation: A Comparison of Industrial and Archival Concerns, in P. Luner, ed., *Paper Preservation: Current Issues and Recent Developments*, TAPPI Press, Atlanta (1990) 63-68

- 13 Mecklenburg M.F., and C.S. Tumosa, 'Mechanical Behavior of Paintings Subjected to Changes in Temperature and Relative Humidity', in M.F. Mecklenburg, ed., *Art in Transit: Studies in the Transport of Paintings*, National Gallery of Art, Washington, (1991), 173-216.
- 14 Mecklenburg, M.F., C.S. Tumosa, and M.H. McCormick-Goodhart, 'A General Method for Determining the Mechanical Properties Needed for the Computer Analysis of Polymeric Structures Subjected to Changes in Temperature and Relative Humidity', in P.B. Vandiver, J. Druzik, G.S. Wheeler, and I.C. Freestone, eds., *Materials Issues in Art & Archaeology III*, Materials Research Society Proceedings, Vol. 283, Pittsburgh, Pa., (1992) 337-358.
- 15 Mecklenburg, M.F., McCormick-Goodhart, M., and Tumosa, C.S., 'Investigation into the Deterioration of Paintings and Photographs Using Computerized Modeling of Stress Development', *JAIC* 33 (1994) 153-70.
- 16 Erhardt, D., and M. Mecklenburg, 'Accelerated vs Natural Aging: Effect of Aging Conditions on the Aging Process of Paper', in P. B. Vandiver et al., eds., *Materials Issues in Art and Archaeology IV: Volume 352- Proceedings from the Fourth Symposium on Materials Issues in Art and Archaeology*, (1994) 247-270.
- 17 Mecklenburg, M. F. and C. S. Tumosa, 'The Relationship of Externally Applied Stresses to Environmentally Induced Stresses', in H. Saadatmanesh and M. R. Ehsani eds., *Fiber Composites in Infrastructure, Proceedings of the First International Conference on Composites in Infrastructure*, NSF and University of Arizona, (1996) 956-971.
- 18 For a written version, see Schulz, W., 'CAL scientists revise guidelines for museum climate control', in *The Torch*, Smithsonian Institution, Washington (December 1994), 3, also reprinted in *WAAC Newsletter*, Western Association for Art Conservation, 17(1) (1995), 23.
- 19 Erhardt, D. and M. Mecklenburg 'Relative Humidity re-examined', in A. Roy & P. Smith (eds), *Preventive Conservation: Practice, Theory and Research. Preprints of the Contributions to the Ottawa Congress*, International Institute for the Conservation of Artistic and Historic Works (IIC), London (1994), 28-31.
- 20 Tumosa, C. S., D. Erhardt, M. F. Mecklenburg, and M. McCormick-Goodhart, 'The Effects of Relative Humidity and Temperature on Exhibited Objects', *ICOM-CC Study Series* (1), (1995) 9.
- 21 Erhardt D., M. F. Mecklenburg, C. S. Tumosa, and M. McCormick-Goodhart, 'The Determination of Allowable RH Fluctuations', *WAAC Newsletter*, 17(1), (1995) 19-23.
- 22 Erhardt, D., M. F. Mecklenburg, C. S. Tumosa, and T. M. Olstad, 'New vs Old Wood: Differences and Similarities in Physical, Mechanical, and Chemical Properties', *ICOM Committee for Conservation Preprints 1996, Volume II*, James and James, London (1996) 903-910.
- 23 Erhardt, D., M. F. Mecklenburg, C. S. Tumosa, and M. McCormick-Goodhart, 'The Determination of Appropriate Museum Environments', in S. Bradley, ed., *British Museum Occasional Paper Number 116, The Interface Between Science and Conservation*, The British Museum, London, (1997)153-163.
- 24 Mecklenburg, M. F., C. S. Tumosa, and D. Erhardt, 'Structural Response of Painted Wood Surfaces to Changes in Ambient Relative Humidity', in V. Dorge and F. C. Howlett, eds., *Painted Wood: History and Conservation*, The Getty Conservation Institute, (1998) 464-483.
- 25 Erhardt, D., C. S. Tumosa, and M. F. Mecklenburg, 'Material consequences of the aging of paper', *ICOM Committee for Conservation Preprints 1999, Volume II*, James and James, London (1999) 501-506.
- 26 Mecklenburg, M. F. and C. S. Tumosa, 'Temperature and Relative Humidity Effects on the Mechanical and Chemical Stability of Collections', *ASHRAE Journal* 41(4), (1999) 77-82.
- 27 Erhardt, D., C. S. Tumosa, and M. F. Mecklenburg, 'Chemical and Physical Changes in Naturally and Accelerated Aged Cellulose', *Historic Textiles, Papers, and Polymers in Museums*, American Chemical Society Symposium 779, American Chemical Society, Washington, (2000) 23-37.
- 28 Erhardt D., C. S. Tumosa, and M. F. Mecklenburg, 'Natural and Accelerated Thermal Aging of Oil Paint Films', A. Roy and P. Smith, eds., *Tradition and Innovation: Advances in Conservation*, The International Institute for Conservation of Historic and Artistic Works, London, (2000) 65-69.

- 28 Mecklenburg, M. F., C. S. Tumosa and A. Pride, 'Preserving Legacy Buildings', *ASHRAE Journal* 46(6), (2004) S18-S23 .
- 29 Hagan, E., E. Quasney, and Mecklenburg, M.F., 'A Parametric Analysis of Relative Humidity Effects on Traditional Panel Paintings', *Materials Research Society Symposium Proceedings*, Vol. 852, (2005) 3-11.
- 30 Mecklenburg, M.F, 'The Structure of Canvas Supported Paintings', *Preprints of the International Conference on Painting Conservation, Canvases: Behavior, Deterioration and Treatment*, Valencia, Spain, March 2005, (2005) 119-155.
- 31 Personal communication to M. Mecklenburg from Dave Hauk, Chief, Smithsonian Institution Energy Group.



This work is licensed under a Creative Commons Attribution - Noncommercial - No Derivative Works 3.0 Licence.

MICRO CLIMATES AND MOISTURE INDUCED DAMAGE TO PAINTINGS

MARION F. MECKLENBURG

ABSTRACT

Because of cold climates and minimal insulation in the walls of many buildings, the inside surfaces of exterior walls reach the dew point. Very high humidity levels and even condensation can occur on these surfaces. On hot summer days these same walls can reach elevated temperatures where the relative humidity near the interior surface can drop to as low as 30%. The zone close to such walls represents micro-climates that can differ widely from the intended “controlled” climates of museums and galleries. As a consequence, considerable damage to works of art can occur. This paper discusses some of the mechanisms that cause the damage to canvas paintings.

MICRO CLIMATES NEAR THE INTERIOR SURFACES OF EXTERIOR WALLS

The most frequently encountered damage to paintings, both on canvas and on wood, results from exposure to high moisture levels. In both new and old historic buildings, moisture can condense on the inside of exterior walls from a variety of reasons. One of those reasons is the excessive humidification of the interior spaces of the building in the wintertime.

Figure 1 shows condensing water leaking from the exterior walls of the Smithsonian Institution’s



Figure 1. Condensed water leaking from the joints in the wall of the Smithsonian Institution’s Hirshhorn Museum and Sculpture Garden in the wintertime. (Photo by Gary Johannsen and Kevin Guifreda)

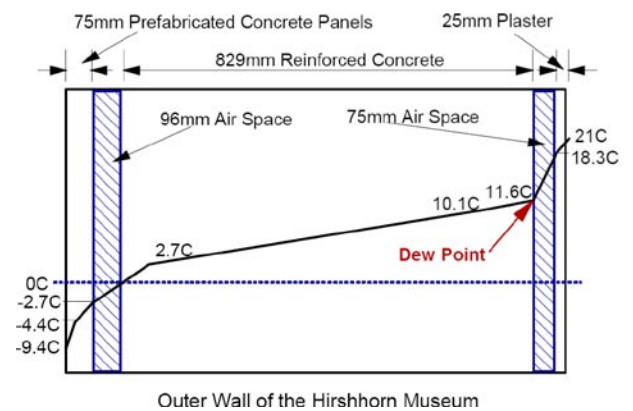

Figure 2. A computer generated temperature profile of an existing wall at the Hirshhorn Museum and Sculpture Garden. The inside surface is to the right. [1]

Hirshhorn Museum and Sculpture Garden. This water is a result of condensing humidified air within the walls on cold winter days. The Hirshhorn Museum and Sculpture Garden opened to the public on Oct. 4, 1974, so it is a relatively new building. Because of the architectural design of the building, the structural walls are massive. None the less, the walls get cold and the condensation occurs.

Figure 2 shows the temperature profile of an existing wall at the Hirshhorn Museum. The reinforced concrete structural wall is 892mm thick and where there are two air spaces, there is no insulation. On very cold winter days it can reach -10C outdoors where the interior environment of the building is 21C and 55% RH. While the temperature profile in Fig. 2 was generated by computer, actual measurements of select spaces verified that the outside, inside and inner wall temperatures are fairly accurate.

In the United States, many older buildings are constructed of brick masonry, no insulation, minimal air spaces, and highly decorative plaster interiors. These buildings are often converted for use as galleries and historic house museums. Some have been retrofitted with sophisticated heating, ventilation and air conditioning (HVAC) systems. In the winter time, the exterior walls of older buildings can get quite cold and the interior surfaces can reach the dew point because of elevated indoor RH levels.



Figure 3. Condensed moisture running down the wall from behind one of several paintings at the Renwick Gallery of the Smithsonian Institution in Washington, D.C. (Photograph courtesy of Ehrenkrantz, Eckstut & Kuhn, Architects)

Figure 3 shows condensed water running down the interior face of an exterior wall from behind a painting at the Renwick Gallery of the Smithsonian Institution. The walls are 660 mm thick brick masonry walls having a 25 mm air space and a 25mm plaster finish. There is no insulation. The painting acted as insulation along the lower edge where there was contact with the wall. Moisture condensed at this lower edge. In this case the outdoor temperature was around -10°C and the temperature and relative humidity of the interior spaces was 21°C and 50%, with a dew point of 10°C .

In the summer time, the exterior walls get hot and the space behind the painting can be warmer than the interior of the exhibition gallery. If the outside wall surface temperature is 35°C (or hotter if in direct sunlight) there is a potential for the inside of the wall to reach a temperature of 28°C or more. In such cases the relative humidity behind the painting drops and can get as low as 33% or less. The microclimate behind paintings hanging on the inside of an exterior wall is entirely different from the “controlled climate” in the center of the gallery space. Behind paintings hanging on exterior walls it is entirely possible to have annual RH fluctuations from 30% to 100% while the center of the interior space is maintaining a constant 50% RH.

THE EFFECTS OF CYCLING RH ON CANVAS PAINTINGS

Canvas paintings represent some of the most complex structures in the cultural world. This is because of the widely varied materials used and their independent response to the environment. This can be illustrated by looking at each layer of a typical painting individually and then superimposing the



Figure 4. The construction of a traditional canvas supported painting. This assembly includes the “support” canvas, a glue size layer, an oil ground and the oil design layers. This particular section was from a 19th century Italian painting. The green bar at the top of the picture is 1mm. (The cross-section and photograph courtesy of Melvin J. Wachowiak)

layers together. A cross-section of a traditional 19th century Italian canvas supported oil painting is shown in Fig. 4. This assembly includes the “support” canvas, a glue size layer, an oil ground and the oil design layers. The glue size layer is almost too thin to see.

Figure 5 shows a detail of the same 19th century Italian painting but looking from the front. The glue size layer is an extremely thin film bridging the gaps in the weave of the canvas. Even though very thin, this layer is still very responsive to changes in RH.

It is commonly assumed that the canvas is the support of an old master painting but in fact the glue size provides support over most of the RH range. [2] This can be illustrated by looking at the individual layers of the painting when they are restrained and subjected to changes in relative humidity. While exploring each layer’s response to environmental changes it is possible to determine the actual mechanisms that cause damage at different levels of relative humidity.

It is possible to measure the magnitude of forces in restrained linen samples as the RH changes. Note that the force per unit width acting on individual materials is used in this paper, since it is not



Figure 5. A detail of the same 19th century Italian painting shown in Fig. 4 but looking from the front. (Photograph courtesy of Melvin J. Wachowiak)

practical to calculate the stresses in textiles as force per unit area. Also, each of the materials examined will be of the thickness that might be encountered in typical easel paintings. Using this strategy, it is also possible to include the effects of the thicknesses of each of the different layers.

In building the composite painting up from the support canvas, it is useful to start with the canvas. The sample of linen tested was from an Ulster #8800 canvas. It is a medium weight canvas such as would be found on many easel paintings. Both the warp and weft directions were tested. An initial force was applied to the specimens at mid RH and the relative humidity was incrementally changed while the new level of force per width was recorded. As the relative humidity changed, so did the force acting on the canvas. This was continued for several cycles over a large range of relative humidity.

Figure 6 shows that between 10% RH and 60% RH there is relatively little change in the force on either the warp or fill directions of the textile. From 70% RH on there is a gradual increase in stress and above 80% RH the force increases dramatically. When damp or wet, loose textiles shrink dramatically and when restrained the shrinkage shows up as significant forces in the textile. This is the first indication that dramatic events take place in canvas paintings when the humidity gets very high. This behaviour was replicated using a wide variety of different textiles by Gerry Hedley at the Canadian Conservation Institute. [3]

Of all of the materials used in canvas paintings, hide glue is the strongest and nearly the stiffest. It is also the one material that develops the most force when restrained and desiccated. It is because this material is both stiff (and strong) and has a high dimensional response to humidity that it develops so much force. Figure 7 shows the force per width (stress) developed

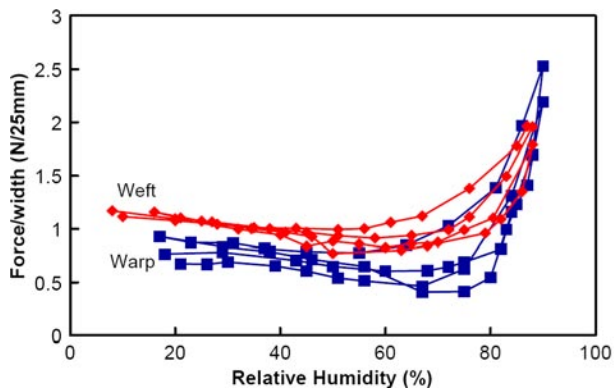

Figure 6. The tensile forces per width, measured in individual restrained samples of the #8800 linen in the warp and fill directions with changing relative humidity. The greatest forces develop when the relative humidity is above 75%.

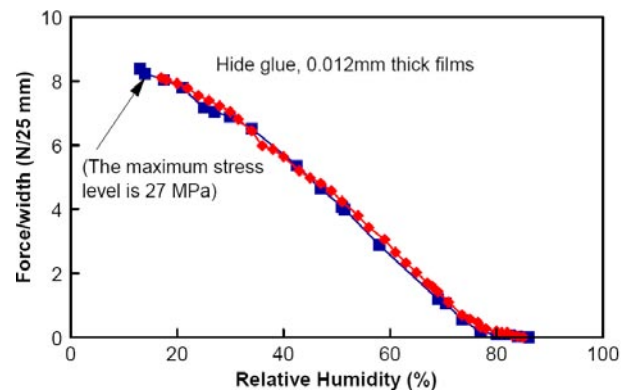

Figure 7. The force per width of restrained samples of hide glue when desiccated from 85% to 15% RH. The stress developed in the hide glue at the maximum force per width of these samples was 27 MPa.

in a very thin film of glue, 0.012mm, when it is restrained and desiccated from 85% to 15% RH. From 80% RH and above, the hide glue has no strength and therefore no ability to maintain the bond between the canvas and ground layers. The thickness of the film is about the same as that found as a size coating on paintings. (See Figures 4 and 5)

In general, the force per width developed in restrained and desiccated oil paint is considerably less than the force per width developed in other materials found in paintings. One of the reasons is that with the exception of some of the paints made with the earth colours, the dimensional response to humidity changes is low. While the earth colors tend to have a higher dimensional response, they have relatively low stiffness. Figure 8 shows two paint samples restrained and desiccated from around 75% to 5% RH. Even with this large change in relative humidity, the forces developed are low. So the likelihood that large excursions to low humidity can damage the oil paint layer is low. It takes a combination of

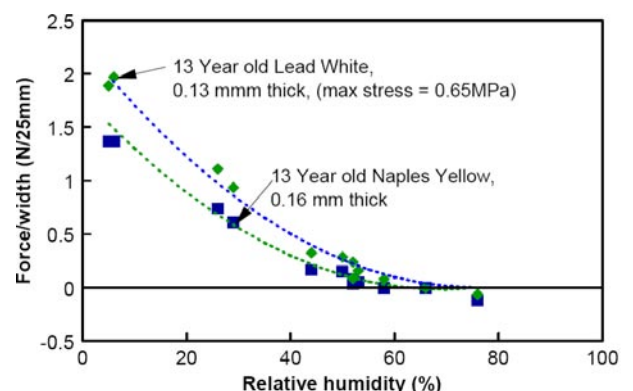

Figure 8. The force per width of restrained samples of lead white and Naples yellow oil paints. The stress of the white lead paint at the maximum force per width of this sample was only 0.65 MPa. The force per width of the paints is considerably lower than the hide glue and a bit higher than the #8800 linen shown in figure 6. The thicknesses indicated for the paint samples is typical of those found in paintings.

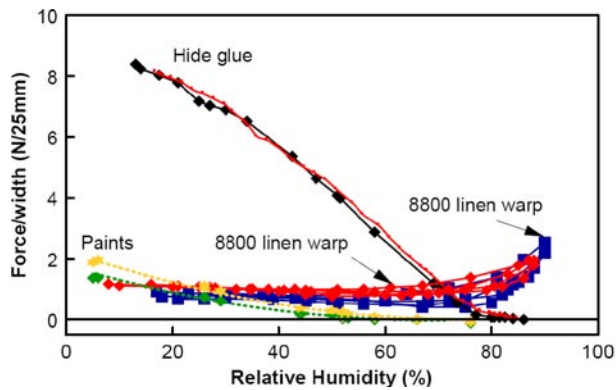

Figure 9. The force per width of restrained samples of linen, hide glue, and lead white and Naples yellow oil paints. The thickness of these films are as shown in their individual figures and would be typical of an oil painting. Using this figure it is possible to compare the responses of the individual layers to that of an actual canvas painting and to determine the different forces occurring at different levels of RH.

materials and their individual responses to changes in humidity to cause deterioration. This can be demonstrated by superimposing all of the layers of a painting together and comparing the results with an actual painting.

SUPERPOSITION OF THE DIFFERENT LAYERS OF A PAINTING

The information from Figs. 6, 7, and 8 is plotted on the same graph in Fig. 9. This makes it possible to compare the responses of the individual layers of a canvas painting to RH and to identify the RH levels that hold the most potential for damage. For example the fabric is developing high forces only at high RH levels and staying relatively constant at humidity levels below 80%. The hide glue is developing high forces at very low RH levels but loses all strength at levels above 80%RH. The paint films are developing relatively low forces and that is only at very low levels of RH.

THE RESTRAINED TESTING OF SAMPLES FROM ACTUAL PAINTINGS

Figure 10 shows the force per width developed in restrained samples of a 1906 painting by Duncan Smith. This painting was constructed with a medium weight, machine woven linen fabric, a hide glue size, a lead white ground and a design layer of raw and burnt umber. It is important to note that there are two areas of high force development, one at the very low levels of RH and the other at the very high levels of RH. This is consistent with the force development of hide glue and canvas as

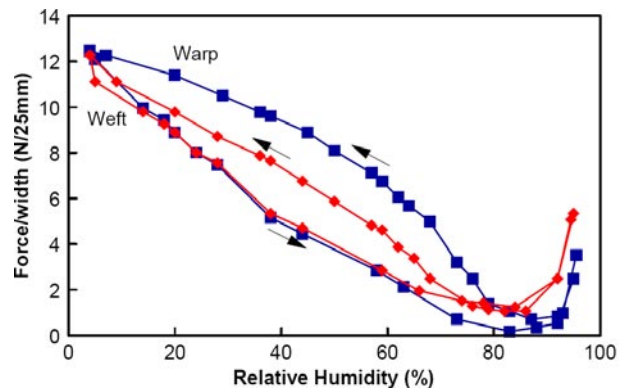

Figure 10. The forces per width of restrained samples of an unknown American portrait painted by Duncan Smith (1906), in both warp and weft directions. These painting samples were constructed with a medium weight machine woven fabric, a hide glue size, a lead white ground and a design layer of raw and burnt umber.

shown in Fig. 9. In the actual painting the fabric is developing high forces at high RH and the glue size is developing high forces at low RH.

Above 80% RH the hide glue is no longer acting as the secure bond between the ground and linen canvas. From 80% RH and above the paint layer is clearly at risk of delaminating from the canvas. At this same RH the paints films are the most flexible but are also in their weakest state. Above 80% RH, the fabric will shrink if loose and certainly could cause delamination of the design layers attached to it. One further comment here is that from 10% RH to 75% RH, the force level in the glue layer is much higher than in the other layers, including the linen canvas. In this range it is the hide glue that is supporting the painting, not the canvas.

Not all linens show the same behaviour. Some linens are woven such that the weft direction yarns are quite straight and have little crimp. It is the crimp in a yarn that causes high humidity shrinkage when loose and high forces when restrained. Also low quality linens can be used for commercially prepared artists' canvases. In order to get a stiffer feel for the linen, heavier layers of glue size are applied before the oil ground is applied. This results in even higher forces in the low humidity ranges.

EFFECTS OF CYCLING CANVAS PAINTINGS OVER LARGE RANGES OF RELATIVE HUMIDITY

If a canvas painting is exposed to large cyclic changes in relative humidity, a pattern of corner cracks can occur. This can be demonstrated by constructing a "mock" painting of canvas, a size layer of hide glue and a "design layer" composed of a hard gesso film

having the mechanical properties of an old brittle oil paint film. The dimensions of the painting were 505mm x 762mm. The gesso layer was a hide glue and calcium carbonate mixture. [4]

Figure 11 illustrates the results of such an experiment. This mock painting was cycled from 90% RH to 35% RH and then back to 90% RH. Each half cycle (from high to low RH or low to high RH) required just less than 24 hours for full equilibration. Periodically, the test painting was examined to see what cracking might have occurred. It was observed that with one small exception, all of the cracks occurred at the corners of the painting. At the ends of selected cycles (#4, #7, and #9), the ends of the cracks were marked.

After nine full cycles the crack extension ceased, as was confirmed by additional cycles. The painting was then subjected to several more severe cycles from 95% RH to 20%RH and back. There was no additional cracking or crack extension. What is of interest is that the first 4 cycles caused the most damage and subsequent cycles only produced smaller increments of crack extension until it ceased altogether. More severe RH cycles did not add to the damage. The cracks that did occur began to act as expansion joints and now the painting can experience large RH cycling without further damage.

From the discussion above, hide glue loses strength at high humidity levels but develops very high stresses when desiccated. It was also shown that, acting alone, paint layers won't generally develop high stresses and damage themselves when restrained and desiccated. It is the desiccation of

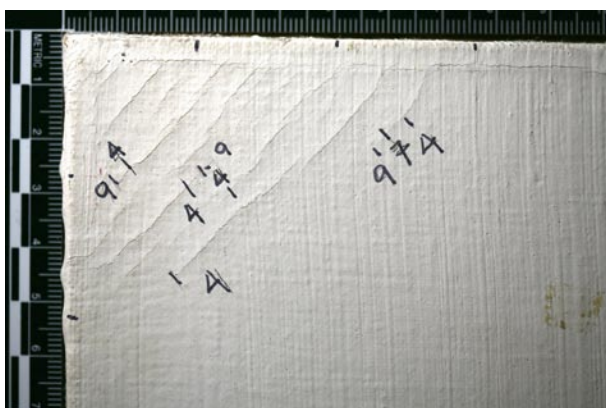

Figure 11. The results of cycling an experimental “mock” painting to cycles of large changes in relative humidity. The cycle range was from 90% RH to 35% RH. The crack limits at 4, 7 and 9 cycles are marked. Additional cycling of a greater RH range beyond the initial nine cycles did no further damage, because the cracks relieved the stresses caused by further RH cycles. This model painting was constructed with a stretched canvas, a hide glue size and a stiff gesso acting as a design layer.

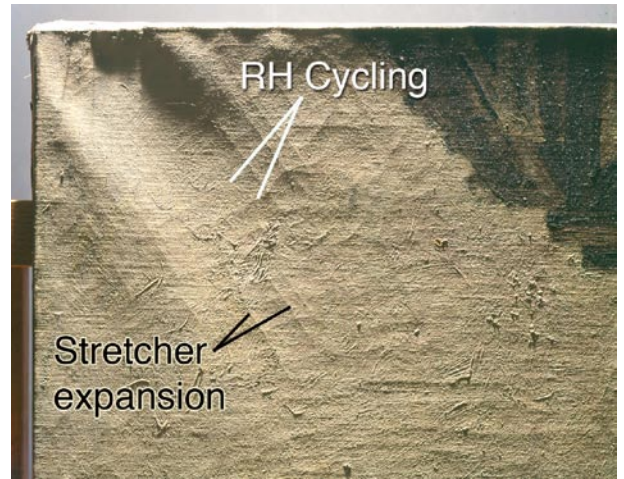

Figure 12. The combination of crack patterns from stretcher expansion and RH cycling over a large range.

the glue layer acting on the paint layer that causes damage. The cracks shown in the corner of the test painting (Fig 11) reflect the effects of the hide glue (and to a small extent the paint itself) pulling from the central regions and away from the corners of the painting. This distorts the design layers sufficiently to cause cracking in the paint layer at the corners.

In an actual painting, it is not unusual to see both the cracking from stretcher expansion and environmental cycling in large ranges of relative humidity combined. This is illustrated in Fig. 12. [5]

CONDENSED MOISTURE DAMAGE TO CANVAS PAINTINGS

One of the most frequently encountered types of damage to paintings, both on canvas and on wood is a result of exposure to high moisture levels. In old historic buildings, the moisture can condense on the inside of exterior walls from a variety of reasons. One reason has already been explained. Another reason that condensation can occur is that in old stone buildings, the masonry walls are cooled during the wintertime. These massive stone walls, due to their high thermal mass, are slow to warm up with the changing seasons and in the spring time warm moist air enters the building along with visitors through open doors. This results in extensive condensation on not only the walls but on paintings hanging on those walls. This occurs on many of the monuments such as the Lincoln and Jefferson Memorials in Washington, D.C. in the United States.

Water condensing on paintings often tends to run to the bottom of the painting and typically causes damage as shown in Fig. 13. In this case there



Figure 13. A detail of a 19th century Italian painting. It is clear that total separation of the paint and ground layers from the canvas has occurred. The amount of moisture was sufficient to cause cracking of the design layers and failure of the bond at the glue layer. The canvas shrank, and the paint cleaved from the canvas. (Photo by Matteo Rossi Doria)

was sufficient water on the canvas that it totally disrupted the adhesive bond of the animal glue size layer. Hence the canvas shrank, glue size lost all of its adhesive strength and the paint and ground layers completely detached from the canvas. Now there is insufficient room to fit the broken pieces of the paint back into proper alignment.

SELECTIVITY IN RH DAMAGE

The chemistry of oil paint is very complex and, understandably, properties of dry films vary with the pigment. For example, paints made with basic lead carbonate dry to tough durable films while those made with the earth colors form weak films. [6 7] The mechanical properties of several different paints are illustrated in Fig 14. One would expect that the white lead paint, because of its strength and low dimensional response to moisture would survive large swings in relative humidity. On the other hand one might suspect that weak and dimensionally responsive paints like umber, ochre, and Sienna would most likely suffer considerable damage in the same harsh environment. [8]

At high moisture levels the earth colours have very little strength and the hide glue size has none. Therefore neither has the ability to resist damage. Failure is going to be preferentially in the earth colours. Figure 15 illustrates selective damage to a 19th century Italian painting. Here the white lead paints are relatively intact while the earth colours are seriously damaged. Clearly avoiding high humidity levels is of primary importance. Moisture induced damage to paintings is selective in that the weaker paints will fail and the durable ones will maintain some stability.

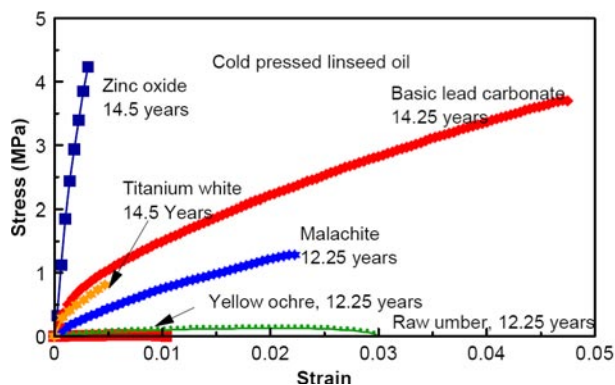

Figure 14. The results of stress-strain tests conducted on paints made with different pigments. The various pigments have a dramatic effect on the mechanical properties of oil paints.

This is in contrast to damage due to excessively low temperatures which has the same adverse effects on all paints. [4, 5]

CONCLUSIONS

While it is possible to show that low relative humidity excursions can cause damage, the most serious RH related damage to paintings is generally a result of very high moisture levels. While the source of the moisture can be leaking roofs or damp basements, a common cause of damage is high humidity and condensation on the inside surface of cold exterior walls. Lowering the indoor relative humidity and keeping an air space between the works of art and the wall can go a long way in minimizing damage. [9]

AUTHOR

Marion F. Mecklenburg, Ph.D.
Smithsonian Museum Conservation Institute
mecklenburgm@si.edu



Figure 15. A detail of a painting containing both white lead paints (blue arrows) and paints made with the earth colours, ochre and sienna (red arrows). This painting was damaged by wet walls. (Photo by Matteo Rossi Doria).

REFERENCES

- 1 This plot was constructed from data taken from “Basis of Design Report, Hirshhorn Museum & Sculpture Garden Repair Exterior Structural Leaks,” OFEO Project No. 0521104, Prepared for the Smithsonian Institution and by HNTB Architecture, (2006), p 81.
- 2 Mecklenburg, M.F., “Some Aspects of the Mechanical Behavior of Fabric Supported Paintings,” Report to the Smithsonian Institution, Research supported under the National Museum Act, (1982)
- 3 Hedley, G. “Relative Humidity and the Stress/Strain Response of Canvas Paintings: Uniaxial Measurements of Naturally Aged Specimens,” *Studies in Conservation*, 33 (1988) 133-148.
- 4 Mecklenburg, M.F., McCormick-Goodhart, M., and Tumosa, C.S., “Investigation into the Deterioration of Paintings and Photographs Using Computerized Modeling of Stress Development,” *JAIC* 33(1994) 153-70.
- 5 Mecklenburg, M.F. and Tumosa, C.S., “Mechanical Behavior of Paintings Subjected to Changes in Temperature and Relative Humidity,” *Art in Transit, Studies in the Transport of Paintings*, M.F. Mecklenburg, Ed. National Gallery of Art, Washington, D.C., (1991), 173- 216.
- 6 Mecklenburg, M. F., C. S. Tumosa and D. Erhardt, “The Changing Mechanical Properties of Aging Oil Paints”, in *Materials Issues in Art and Archaeology, VII, Volume 852*, Materials Research Society (2005), 13-24.
- 7 Tumosa, C. S., Erhardt, D., M. F. Mecklenburg and Xingfang Su, “Linseed Oil Paint as Ionomer: Synthesis and Characterization”, in *Materials Issues in Art and Archaeology, VII, Vol. 852*, Materials Research Society (2005), 25-31.
- 8 Mecklenburg, M.F, “The Structure of Canvas Supported Paintings,” *Preprints of the International Conference on Painting Conservation, Canvases: Behavior, Deterioration and Treatment*,” Valencia, Spain, March 2005, 119-155.
- 9 Mecklenburg, M. F., C. S. Tumosa and A. Pride, “Preserving Legacy Buildings”, *ASHRAE Journal* 46(6):S, 2004, 18-S23.



This work is licensed under a Creative Commons Attribution - Noncommercial - No Derivative Works 3.0 Licence.

CANVAS PAINTINGS ON COLD WALLS: RELATIVE HUMIDITY DIFFERENCES NEAR THE STRETCHER.

FRANK J. LIGTERINK AND GIOVANNA DI PIETRO

ABSTRACT

A frequently observed phenomenon with canvas paintings is the sharp transition in the condition of canvas and paint layers in the regions directly adjacent to the stretcher, strainer or cross bars and the condition of the painting in the other regions, behind which no wood is present. This paper explores the idea that this transition, referred to as the ‘stretcher effect’, is the result of a local *deviation of the relative humidity* in the vicinity of the stretcher. Two plausible mechanisms, thermal shielding and hygroscopic buffering are investigated both theoretically and experimentally. It was found that thermal gradients cause significant variations in relative humidity near the canvas and thus play a major role in the formation of the stretcher effect.

1 INTRODUCTION

Degradation processes in art objects are usually slow and gradual. Although this situation is preferable from a curator’s point of view, it presents a problem for conservation scientists who would like to clarify the mechanisms responsible for these degradation processes. In the absence of direct information on the behaviour over time, local spatial differences in the condition of a material within a single object can provide important clues to factors that enhance or reduce degradation. These local differences are therefore of special interest to conservation science.

In the field of the conservation of canvas paintings an example of such a local difference is the variation between the condition of the paint layer and of the canvas in the regions directly over the stretcher, strainer or cross bars and the condition of the painting in the other regions behind which no wood is present. From here on we will use the generic term ‘stretcher’ to indicate any part of the wooden support of the canvas, and refer to the local, sharp transition in the condition of the painted canvas as the ‘stretcher effect’. A detail of a painting exhibiting this phenomenon is shown in Figure 1.

Although the ‘stretcher effect’ is well known to paintings conservators [1], no systematic survey has been published to describe the pervasiveness

and the common characteristics and variations of the phenomenon. We believe that such a survey is needed. However in this paper we focus on elucidating the mechanism of its formation.

Various ideas have been proposed to explain the stretcher effect. Those ideas need to explain the sharp transition of the condition of the canvas at the stretcher’s edge. One possible mechanism for the occurrence is a direct *mechanical contact* between stretcher and canvas. In many paintings the stretcher is in close contact with the canvas and it provides direct mechanical support to the canvas. Mechanical vibrations are attenuated where the stretcher is present, but not outside the stretcher region. This attenuation can lead to a locally different condition of the canvas [2]. A second possible mechanism that might lead to the stretcher effect is a *locally modified chemistry* caused by the transfer of volatile components between stretcher and canvas. Although the transfer of volatiles might in principle lead to local variations in the mechanical properties of the canvas and paint layers, no direct experimental evidence is available to support this idea.

The third and probably most popular explanation for the effect is the idea that the presence of the stretcher induces a local *deviation of the relative humidity* behind the canvas which controls the moisture content of the canvas, ground, and paint layers. This local deviation of the moisture content will lead to a locally distinct swelling of the layers in the painting at the stretcher area in comparison to the area where no stretcher is present. Over time this might lead to the ‘stretcher effect’. While differences in the moisture content of the canvas are very difficult to measure directly, the relative humidity of the air in close proximity to the canvas, being an indicator of its moisture content, is easy to measure. A few studies have been published on microclimate and local variations of relative humidity and temperature in paintings and comparable semi-closed environments [3, 4, 5, 6]. In this study we investigate the mechanisms responsible for the occurrence of local relative humidity differences near the canvas. Our curiosity to understand the stretcher effect is related to the use of backing boards in paintings conservation.



Figure 1. An example of the stretcher effect: the condition of the painting is better in the area over the stretcher. Detail (0.3 x 0.3 m) of *The Coronation of Maria*, Church of the Heilige Bavo at Nuth, Netherlands. Photo courtesy Stichting Restauratie Atelier Limburg (SRAL)

2 THEORY OF THE LOCAL STRETCHER CLIMATE

We can think of two distinct properties of the stretcher that are candidates to play a significant role in the formation of a local stretcher climate. Stretchers are made of wood which is both hygroscopic as well as thermally insulating. In the following we will explore two distinct mechanisms through which both properties will affect the local stretcher climate.

HYGROSCOPICALLY INDUCED RELATIVE HUMIDITY DIFFERENCE

In Figure 2, a cross section view of a typical painting geometry with a stretcher adjacent to a canvas plus a wall is shown. Consider a situation in which the overall temperature is maintained constant. Suppose now that all the hygroscopic materials in this painting initially are in equilibrium with a constant relative humidity. In the next stage of this conjectured experiment the relative humidity in the room is changed to a new, let's say lower, level. In reaction to this change, both the stretcher and the canvas will release moisture to the surrounding air. For some time, the moisture content of the canvas in the stretcher area and the relative humidity in the air pocket between stretcher and canvas will remain close to the original level and resist following the general change of relative humidity. The magnitude and duration of the relative humidity difference, and the shape of the relative humidity profile in the stretcher area will depend on the rate of supply of moisture from canvas and wood in competition with the transport of moisture in the narrow air gap between

canvas and stretcher and the loss of water vapour by permeation through the canvas.

In our early work we were inclined to believe that this hygroscopic action of the stretcher would provide a satisfactory explanation for the stretcher effect. However, after performing some calculations for typical dimensions and material characteristics based on earlier studies [7, 8] (see appendix A), we became less convinced.

In the case of paintings well attached against the wall, where the decline of the RH at the back of the canvas takes of the order of hundreds of hours, the model predicts smooth profiles whose level slowly decreases in time (Figure 3a). In this case the permeation through the canvas dominates over the diffusional lateral flow. For smaller values of the canvas water vapour permeability the profiles are reversed but have the same smooth shape.

In the case of paintings hanging at a certain distance from the wall, the decline of the RH on the back of the canvas is of the order of few hours. The model predicts larger differences of relative humidity (Figure 3b). Apart from the first few hours, the shape of the profile is still gradual. This characteristic does not change by reducing the value of the canvas permeability or the distance between the stretcher and the canvas.

We believe that these smooth or short-lived profiles can not explain the sharp transition in the condition of the canvas typical of the stretcher effect.

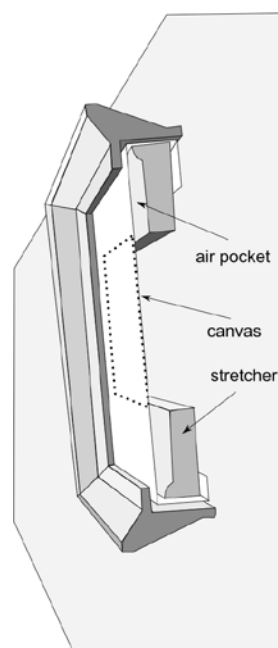

Figure 2. Cross section of a typical painting geometry.

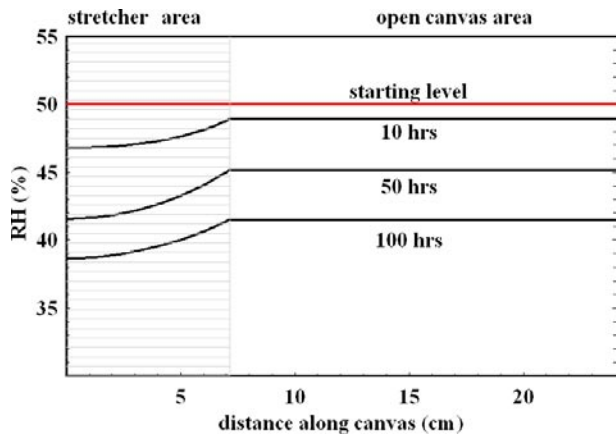

Figure 3a. RH profiles induced by the pure hygroscopic effect. The painting is close fitting against the wall.

THERMALLY INDUCED RELATIVE HUMIDITY DIFFERENCE

This inconsistency made us look for an alternative mechanism that would give rise to a more pronounced local stretcher climate with a sharper transition. The starting point for the development of an alternative mechanism was an early thermograph picture by Urbani [9] of a canvas painting mounted on a wall. The picture clearly shows the pattern of the stretcher and crossbars underneath the painting, indicating a temperature difference. This specific example may represent a general effect that will occur for paintings that are subjected to a temperature difference between room and wall. The stretcher present between canvas and wall will locally block radiative and convective heat transfer between wall and canvas and thus should cause a temperature variation along the canvas with a relatively sharp transition at the stretcher edge. As a consequence, this temperature difference would induce local relative humidity differences.

A quantitative prediction of local relative humidity resulting from spatial temperature differences in a system with hygroscopic materials and air is difficult for a general case. The major difficulty is the complex moisture diffusion behaviour in hygroscopic materials subjected to thermal gradients [10]. However for cases that can be modelled as systems with a number of hygroscopic surfaces at different but individually uniform temperatures, all in contact with a common air volume, the situation is simpler [11].

In most systems subjected to temperature variations, significant convective flow of air will be generated. As a result there will be a constant mixing of air. This mixing will cause the water vapour concentration (absolute humidity) within the air volume to equalize throughout the open space bounded by the

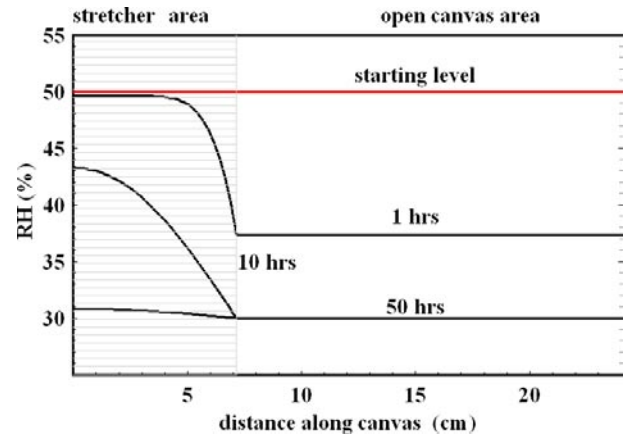

Figure 3b. RH profiles induced by the pure hygroscopic effect. The painting is hanging away from the wall.

different hygroscopic materials. Near surfaces, the temperature of the air will conform to the local surface temperature. The combination of a local surface temperature and a global absolute humidity gives rise to a different relative humidity at each surface. As soon as all local surface relative humidities are in equilibrium with the local moisture contents of the materials, the global absolute humidity will remain constant.

In this study we developed a two-step model to predict the local equilibrium relative humidity values that would result from a given temperature distribution. The starting point is a uniform temperature and RH, with all materials equilibrated to these conditions. A temperature difference is now applied between the wall surface and the room air. The calculation in the model proceeds in two steps. In the first step the new global absolute humidity level that will develop as a result of different contributions of different parts of the system is calculated. Once this global value of absolute humidity has been determined, the local relative humidity can be calculated, everywhere in the system, just depending on the local temperature. This second operation is equivalent to reading relative humidity values from a hygrometric chart at a single absolute humidity level for different local temperatures.

The two-step model (for a full mathematical description see Appendix B) essentially predicts to what extent moisture will migrate from warm to cold material sections of the painting and how final relative humidities will depend on the relative masses of the material sections. If the masses of the materials in the cold sections exceed the masses of the materials in the warm sections there will be an overall decrease of the relative humidities. In the opposite case there will be an overall increase of the relative humidities and condensation can take place at the cold sides. Box

BOX A SIMPLE SYSTEM WITH HOT AND COLD MASSES

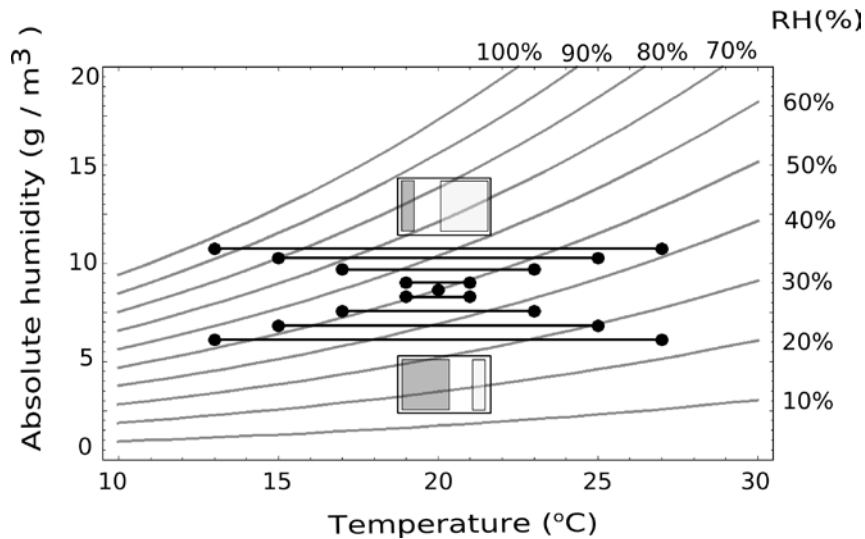

To illustrate the model of equation 8 (appendix B), we consider here a simplified situation of an inert, moisture impermeable box containing two separate sections of hygroscopic material with different masses in a ratio of 4:1.

Starting from a uniform distribution of both temperature and relative humidity at 20 °C and 50%, we will consider the effect of cooling one section of hygroscopic material in the box to a temperature of 13°C while heating the other section to 27°C in equal steps simultaneously. For two distinct cases, the local temperatures and the resulting humidity conditions are plotted in the hygrometric chart above:

1. Major mass heated and minor mass cooled

Due to the fact that the major mass is heated its moisture release will dominate the process. The global absolute humidity level will increase from its starting level of 8.7 g/m³ to a level of 10.7 g/m³

resulting in two separate relative humidity values at 95% and 42% respectively. It should be noted that the relative humidity at the cold mass is approaching condensation conditions.

2. Major mass cooled and minor mass heated

Due to the fact that the major mass is cooled its moisture uptake will dominate the process. The global absolute humidity level will decrease from its starting level of 8.7 g/m³ to a level of 6.1 g/m³, resulting in two separate relative humidity values at 54% and 24% respectively. It should be noted that the relative humidity at the warm mass is approaching comparatively dry conditions.

The major point to note in this simple example is that the mass distribution in a system exposed to a temperature gradient plays an essential role in determining the resulting relative humidity conditions.

1 shows the results of this calculation for a simple system.

3 EXPERIMENTAL SET-UP AND PROCEDURE

In order to test our hypothesis that local differences in moisture content of the canvas and paint layers are mainly determined by spatial temperature gradients we developed experiments in which a canvas painting could be exposed to both temperature and relative humidity gradients.

Our experimental set-up consisted of a mock-up painting set against a wall which could be cooled, inside a walk-in climate room. We designed the

painting so that it would have the typical moisture and heat transfer of a painting hanging closely against a wall but be simple enough to be understood with relatively simple math. We first describe the climate room, then the wall and finally the painting. Details about the materials and instruments will be given at the end of the paragraph.

The climate walk-in room has relative humidity and temperature controlled by a standard air-conditioning system. Both the temperature and the relative humidity can be changed within a few minutes. A relative humidity gradient across the painting is established by suddenly changing the RH in the room. Due to the low permeability of the

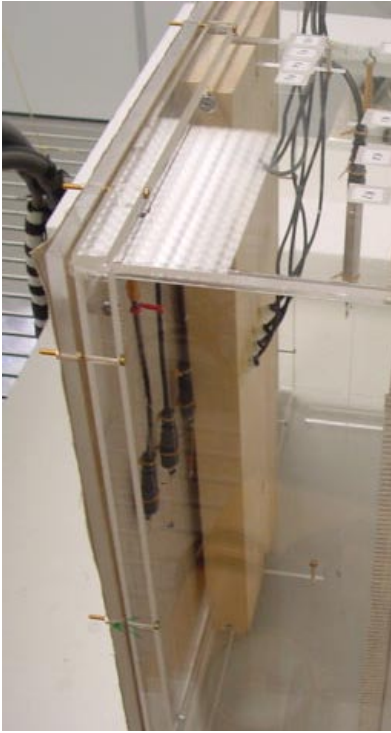

Figure 4. Side view of the mock-up painting with insulation material removed. It shows the acrylic frame, the canvas and the array of sensors positioned along the stretcher bar.

canvas, it will take a certain time for the relative humidity behind the painting to reach equilibrium with the room.

The wall is a gypsum wall containing internal water pipes connected to a thermostat. The wall was covered with a plastic foil and a cardboard sheet to give it well defined hygroscopic behaviour.

The painting is a canvas attached to an acrylic frame hanging on the wall.

The air conditioning system in the climate room produces strong air currents which can push air behind the painting, so we closed the gap between painting and wall and we thermally insulated the sides of the painting. To imitate a stretcher, we placed a wooden bar behind the centre line of the canvas.

In order to study the effects of individual hygroscopic surfaces, as predicted by the two-step model, we designed the experiment so that the hygroscopicity of the wall and of the wooden bar could be varied. When we wanted to imitate a system with a suppressed hygroscopicity, the stretcher was covered with a plastic foil and the cardboard was removed from the wall.

We measured the surface temperatures of the wall and of the two faces of the wooden bar with sensors glued to the surfaces. The temperature profile on the canvas surface was measured by bending the temperature heads of six RH&T sensors. The relative humidity and temperature of the air close to the wall was measured by a single RH&T sensor. The relative humidity of the air close to the canvas was measured with the RH heads of the previously mentioned six sensors. Three sensors were placed in slanting holes in the bar with their heads sticking out of the stretcher. Another three sensors were attached to nylon threads stretched from the bottom to the top of the frame (Figure 4).

The system is an enclosed volume with a number of surfaces: the canvas, the stretcher and the wall (Figure 5) Nine different hygroscopic surface units are distinguished: the wall, the two stretcher surfaces and six strips of canvas. The relative humidity is measured in seven locations: in the open space between wall and stretcher and in the six locations along the canvas. At these RH-sensors we did not measure the temperatures separately and therefore we had to estimate them. The temperature at the RH-sensors measuring in the air pocket between canvas and stretcher was taken as the interpolation between the measured temperatures at the canvas and at the stretcher surface. The temperature of the RH-sensors in the open canvas area was taken as the average between the canvas surface temperature and the temperature of the air region near the wall.

EXPERIMENTS

The first experiment was designed to investigate hygroscopically induced humidity differences. A relative humidity gradient across the painting was induced by suddenly changing the relative humidity

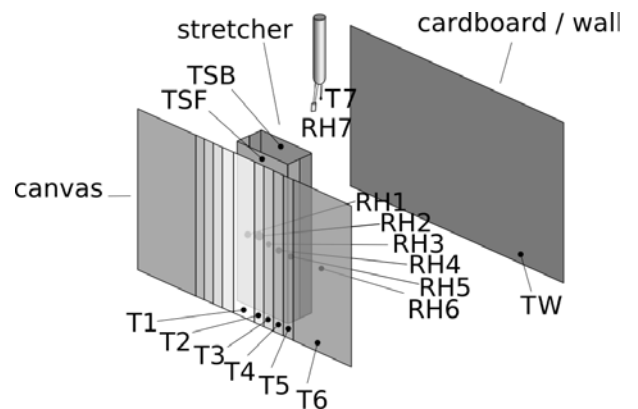

Figure 5. Diagrammatic sketch of the hygroscopic surface units present in the painting with indication of temperature and relative humidity sensor positions.

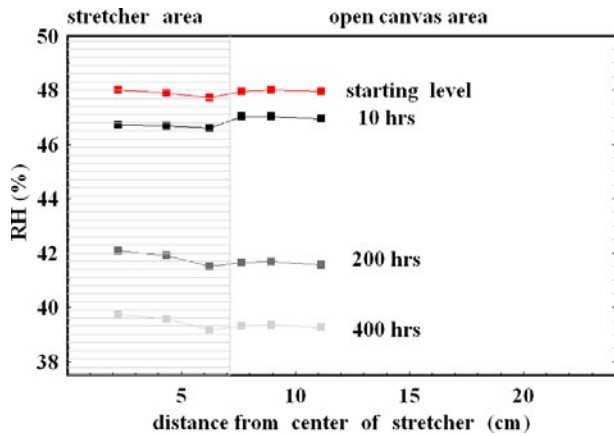

Figure 6. Relative humidity profiles along the canvas measured in the first experiment after 0, 10, 200 and 400 hours after the sudden decrease of relative humidity in the room. The striped area is the region occupied by the stretcher .

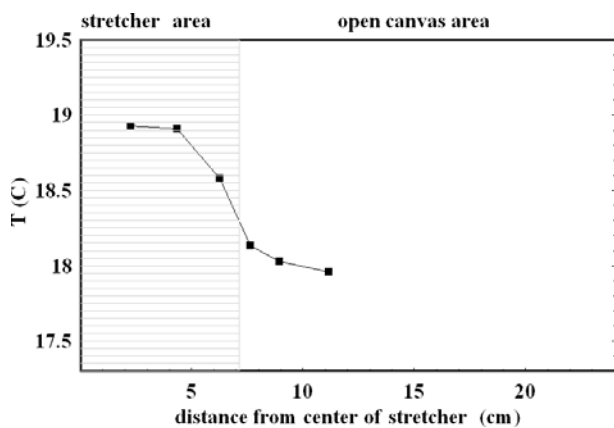

Figure 7. Temperature profile along the canvas in the second experiment. The striped area is the region occupied by the stretcher.

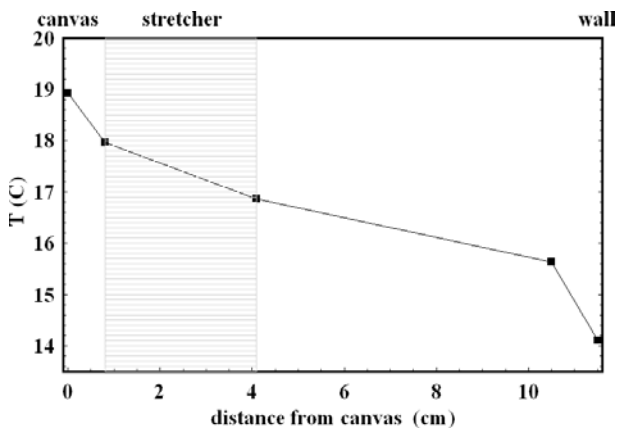

Figure 8. The temperature profile in the direction perpendicular to the canvas in the second experiment. The lines are to guide the eye. The striped area is the region occupied by the stretcher.

in the room from 50 % to 30 %, while keeping the temperature constant at 20 °C.

The second and third experiments were designed to investigate thermally induced relative humidity differences. A thermal gradient was created by

keeping the relative humidity and the temperature in the room constant at 50% and 20 °C and decreasing the temperature of the wall to 14 °C. In the second experiment the hygroscopicity of the wall and stretcher were suppressed by temporarily removing the cardboard from the wall and covering the stretcher with a plastic foil. In the third experiment the hygroscopic action of stretcher and cardboard was restored.

DETAILS OF THE MATERIALS AND INSTRUMENTS USED AND ON THE RH AND T VALUES.

The painting has an oil-primed canvas of dimension 48.5×48.5 cm glued to a polymethyl methacrylate (PMMA) frame designed to keep the canvas at 11.5 cm from the wall. The space between the frame and the wall is closed with PMMA strips screwed to the frame. The edges of this construction are sealed with waterproof tape and insulated with polystyrene foam board to prevent moisture and heat exchange through the sides of the assembly. The stretcher is a pine wood bar of $48 \times 14.3 \times 3.3$ cm. It is placed 0.8 cm from the canvas. The cardboard used to cover the wall area is an alkaline Moorman cardboard with density of 1200 g.m^{-2} .

The RH&T sensors are capacitance and NTC thermistor sensors produced by Hygrotech, Germany (Semi 833 NTC and Humicor 5000). The relative humidity heads are positioned at approximately 0.5 cm distance from the canvas. The temperature of the wooden bar and of the wall was monitored with thermocouples. The temperature and relative humidity in the room was monitored with two Vaisala HMM 30D sensors.

4 RESULTS AND DISCUSSION

Figure 6 shows the relative humidity profile along the canvas measured in the first experiment where the system was subjected to a relative humidity change and the temperature was kept constant and homogeneous. The profiles at 0, 10, 200 and 400 hours after the sudden decrease of relative humidity in the room from 50% to 30% are shown in the graph. The RH profile shifts downwards with time, due to the leakage of moisture from the system to the room through the canvas. The slow approach to 30% RH is caused by buffering by the wood and cardboard.

In disagreement with our diffusion models, the observed RH profiles are flat within the experimental error. Hence, exposure to pure relative

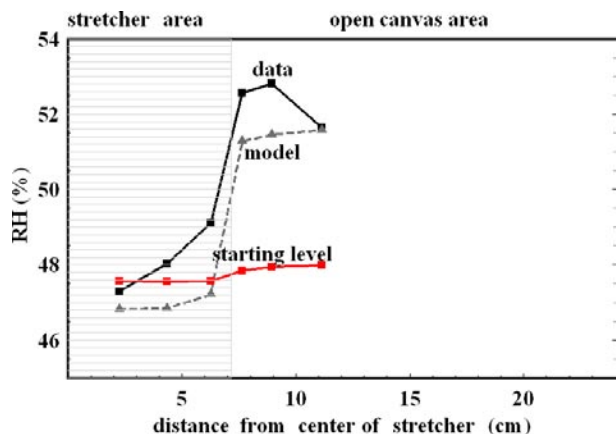

Figure 9. Measured and calculated relative humidity profile along the canvas in the second experiment (stretcher and wall buffering suppressed).

humidity gradients across canvas paintings does not induce significant relative humidity profiles. This means that the moisture content of the canvas also does not change significantly along the canvas and therefore that, under typical values of distance between stretcher and canvas like the one used in the experiments, pure relative humidity gradients cannot induce the stretcher effect.

Figures 7 to 10 show the results of the second and third experiment, where the system was subjected to a gradient in temperature. After starting the cooling procedure it takes 6 hours to reach a steady temperature gradient between room and wall. Figure 7 shows the temperature profile in the plane of the canvas. Figure 8 shows the temperature profile perpendicular to the canvas. The temperature difference between the centre of the stretcher and the centre of the free canvas is one degree. The perpendicular temperature profile shows that the temperature of the canvas is close to the room temperature, 20 °C. Very similar temperature profiles were observed in the third experiment.

Figure 9 shows both the measured relative humidity profile along the canvas in the second experiment once the temperature profile had reached stability, and the predicted profile calculated by applying equation B8 (appendix B). The parameters needed to calculate the profile are listed in Table 1a. The profile is very steep at the stretcher edges. The total relative humidity difference is about 5%. The model is in good agreement with the experimental results.

Figure 10 shows three measured relative humidity profiles along the canvas in the third experiment (with buffering by wall, stretcher and canvas) at 0, 6, 200 and 500 hrs after applying the thermal gradient, and the predicted profile after 6 hrs. The parameters needed to calculate the profile are listed in Table

1b. The relative humidity profile is steep at the stretcher edges and it levels out at the centre of the stretcher and in the region of the canvas not covered by the stretcher. The shape of the profile is constant but moves to a higher RH with time. The relative humidity started at 47%. After 6 hours from applying the thermal gradient the relative humidity between canvas and stretcher had dropped to about 40% due to the absorption of moisture by the materials whose temperature was decreased. This relatively large reduction in RH is primarily caused by the substantial cooling of the cardboard against the wall. Afterwards the level of relative humidity increased due to equilibration with the water vapour content of the room, into the system through the canvas. The model matches well the experimental results.

5 CONCLUSIONS

The measured and predicted magnitude and steepness of relative humidity profiles along the stretcher indicate that the stretcher effect found in canvas paintings is most likely due to temperature induced relative humidity gradients in the plane of the canvas. The direct local hygroscopic action of the stretcher wood is negligible. Our experimental results are in good agreement with the proposed model for thermally induced relative humidity differences. The model shows that the moisture distribution in objects like paintings depends strongly on the presence of temperature gradients and on the distribution of the dry masses within the object. Moisture will accumulate in cold hygroscopic materials and can practically only be controlled if temperature gradients are reduced.

This study provides a quantitative argument to confirm the idea of Padfield and co-workers (2001)

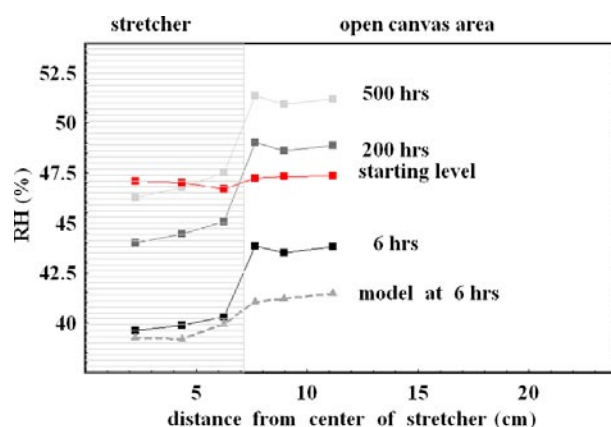

Figure 10. Relative humidity profile measured along the canvas in the third experiment (with buffering by absorbent wood and wall) after 0, 6, 200 and 500 hours from the setting up of the thermal gradient, and the calculated profile after 6 hours.

Initial Condition	Mass of Hygroscopic surf. (g) (*)	Temperature of surfaces (C)	New level of Abs. Humidity	Interpolated Air Temp. (C) (**)	Calculated Air Hum. (%)
RH = 48%	M1 = 11.88	TS1=18.9	AH=6.14 g/m ³	TA1 = 18.3	RH1 = 46.8
T = 20 C	M2 = 7.2	TS2=18.9		TA2 = 18.3	RH2 = 46.8
	M3 = 6.66	TS3=18.6		TA3 = 18.2	RH3 = 47.2
AH =8.31 g/m ³	M4 = 4.14	TS4=18.1		TA4 = 16.9	RH4 = 51.3
	M5 = 6.3	TS5=18.0		TA5 = 16.8	RH5 = 51.4
	M6 = 44.82	TS6=17.9		TA6 = 16.8	RH6 = 51.6

Table 1a. Parameters and results for the humidity profile in the second experiment (see Figure 4 for the location of the surfaces and of the measuring points)

Initial Condition	Mass of Hygroscopic surf. (g) (*)	Temperature of surfaces (C) (***)	New level of Abs. Humidity	Interpolated Air Temp. (C) (**)	Calculated Air Hum. (%)
RH = 47%	M1 = 11.88	TS1 = 18.9	AH=5.44 g/m ³	TA1 = 18.4	RH1 = 40.3
	T = 20 C	M2 = 7.2		TS2 = 19.0	TA2 = 18.4
M3 = 6.66		TS3 = 18.7		TA3 = 18.3	RH3 = 40.6
M4 = 4.14		TS4 = 18.2		TA4 = 17.0	RH4 = 44.0
AH =8.13 g/m ³	M5 = 6.3	TS5 = 18.2		TA5 = 17.0	RH5 = 44.0
	M6 = 44.82	TS6 = 18.1		TA6 = 17.0	RH6 = 44.2
	MSF = 40.72	TSF = 18.1			
	MSB = 40.72	TSB = 17.0			
	MW= 282.27	TW = 13.6			

Table 1b. Parameters and results for the humidity profile in the third experiment (see Figure 4 for the location of the surfaces and of the measuring points)

(*) Mass of the canvas units: $M = s_w \times s_h \times \sigma$, where s_w is the strip width, s_h is the strip height (45 cm) and σ is the surface density of the canvas (0.04 g cm⁻²). The strip widths are respectively 6.6 cm, 4 cm, 3.7 cm, 2.3 cm, 3.5 cm and 24.9 cm. , Mass of stretcher surfaces: $M = S \times \rho \times d$, where S is half of the total stretcher surface (792 cm²), ρ is the wood density (0.6 g cm⁻³) and d (0.086 cm) is the effective thickness of the wood, calculated as $d = (D \times t)^{1/2}$, with D the diffusion constant of moisture in wood (3.4×10^{-7} cm² s⁻¹) [8] and t the time past since the beginning of the experiment (6×3600 s).

Mass of cardboard on wall: $M = c_w \times c_h \times \sigma$ where c_w is the cardboard width (48.5 cm), c_h is the cardboard height (48.5 cm) and σ is the surface density (0.12 g cm⁻²).

(**) The temperature at points 1, 2 and 3 is interpolated based on a linear profile between the temperature of the canvas and the temperature of the front face of the stretcher. The temperature at points 4, 5 and 6 is the average between the temperature of the canvas and the temperature $T7$ (15.6 C).

(***) In the third experiment the wall was covered by a cardboard sheet and the temperature of the wall was measured under the cardboard sheet. This underestimates the actual cardboard temperature which was therefore in the calculation assumed to be equal to $T7$ (15.6 C).

who claim that when backboard protections are applied to drawings directly in thermal contact with cold walls, they may accumulate substantial amounts of moisture, which in changing temperature conditions can be released and result in dangerously high relative humidity values.

Although this study is aimed at the specific issue of the stretcher climate, we believe that the effects of temperature variation in semi-enclosed systems are of general importance in preventive conservation. The model we present is a powerful tool to predict and understand the distribution of the relative humidity in the general case of semi-closed systems subjected to temperature gradients.

AUTHORS

Frank J. Ligterink.
Instituut Collectie Nederland, Gabriel Metsustraat 8,
1071 EA Amsterdam, The Netherlands
phone: +31.20.3054775, fax: +31.20.3054700,
www.icn.nl,
frank.ligterink@icn.nl

Giovanna Di Pietro.
Meltingerstrasse 17,
CH-4053 Basel, Switzerland,
phone: +41.61.3611340,
giovanna.dipietro@gmail.com

REFERENCES

- 1 Achternkamp, P. 1991. *Die Rückseitenschutz von Gemälden: Historische und zeitgenössische Praxis*, Zeitschrift für Kunsttechnologie und Konservierung 5 (1): 17-47.
- 2 Green, T. 1987. *Shock and vibration - test results for framed paintings on canvas supports*. Proceedings of the ICOM-CC 8th triennial meeting in Sydney, Getty Conservation Institute, Marina del Rey: 585-596.
- 3 Kaufmann, M. 1991. *Studien zur Problematik der Speziellen Klimasituation am Leinwandbild*. Zeitschrift für Kunsttechnologie und Konservierung, 5: 59-73.
- 4 Toishi, K. 1994. *A Note on the Movement of Moisture Between the Components in a Sealed Package*. Studies in conservation 39 (4): 265-271.
- 5 Ranacher, M. 1995. *Bilder an kalten Wänden, Oberflächentemperaturmessungen an Wänden und Bildern als Neuansatz für konservatorisch richtige Klimatisierung in Gemäldegalerien*, Restauratorenblätter; Band 15: 147-163.
- 6 Padfield, T., Berg, H., Dahlstrom, N., Rischel, A.G. 2001. *How to Protect Glazed Pictures from Climatic Insult*. Proceedings of the ICOM-CC 13th Triennial Meeting in Rio de Janeiro. James & James London Vol. I: 80-85. <http://www.padfield.org/tim/cfys/framepic/glazedpics.pdf>
- 7 Di Pietro G., Ligterink, F.J. 1999. *Predictions of the Relative Humidity Response of Backboard Protected Canvas Paintings*. Studies in Conservation, 44 (4): 269-277.
- 8 Ligterink F.J., Di Pietro, G. 1999. *The Effect of the Wooden Stretcher on the RH Response of Backboard Protected Canvas Paintings*, Proceedings of the ICOM-CC 12th triennial meeting in Lyon, James & James London: 70-76.
- 9 Urbani, G. 1974. *Applicazioni della „Termovisione“ nel Campo della Conservazione delle Opere d'Arte*. In: Problemi di Conservazione (ed. G. Urbani), Bologna, chapter 12, page 326, figure 7.
- 10 Lykow, AW, 1958. *Transporterscheinungen in kapillarporösen Körpern*. Akademie-Verlag, Berlin.
- 11 Hazeu, W., Hueck, H.J. 1966. *Changes of Humidity Inside Packages Due to Environmental Conditions*, Society of chemical industry, Monograph Series, 23: 224-231.
- 12 Morton W.E., Hearle, J.W.S. 1993. *Physical properties of textile fibers*. The Textile Institute, Manchester.

APPENDIX A. MODEL FOR HYGROSCOPICALLY INDUCED RH DIFFERENCE.

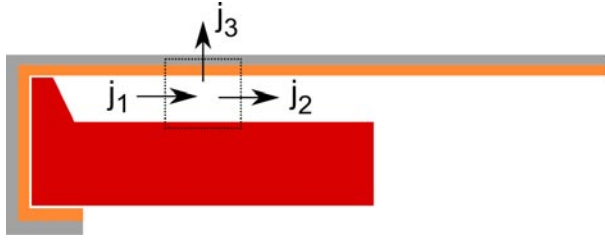

Figure A1. Sketch of the stretcher area with the permeation and diffusional flows determining the moisture transport in the air gap.

We want to calculate the profile of relative humidity building up along the stretcher pocket during the conjectured experiment explained in section 2. Neglecting possible convection of air, three main factors determine the relative humidity profile: the desorption (or absorption) of moisture by the stretcher and the canvas, the diffusion of moisture along the air pocket and the permeation of moisture through the canvas. We will assume that the desorption of moisture by the hygroscopic materials is so quick that the moisture content of the hygroscopic materials is always in equilibrium with the local relative humidity. This means that the contribution of the hygroscopic materials is taken into account by the (linear) relation between the equilibrium moisture content of the materials and the local relative humidity and by the prevailing amount of moisture contained in the hygroscopic materials with respect to air. The contributions of the diffusion of moisture along the air pocket and the permeation of moisture through the canvas are taken into account by assuming that the variation in time of the total moisture $m_V(x,t)$ [g] contained in the small representative volume V [cm³] centered at position x [cm] is given by the balance between the incoming diffusional flow J_1 [g cm² s⁻¹] on one side and the outgoing diffusional flow J_2 [g cm² s⁻¹] and the permeation flow J_3 [g cm² s⁻¹] on the other side (see Figure A1).

The diffusional flows are given by Fick's law while the permeation flow is given by the relation:

$$J_3(x, t) = P \times (RH(x, t) - RH0) \quad [A1]$$

where P [g cm² s⁻¹] is the experimentally determined permeability of the canvas [7, 8] and $RH0$ is the relative humidity level in the room.

Combining these ingredients, the differential equation which needs to be solved to find the relative humidity profile in the air pocket is:

$$\frac{d^2 RH(x, t)}{dx^2} (x, t) + k_1 \times (RH0 - RH(x, t)) \quad [A2]$$

$$= k_2 \times \frac{dRH(x, t)}{dt}$$

with:

$$k_1 = \frac{P}{d \times D \times c_{sat}} \quad [A3]$$

$$k_2 = \frac{\alpha \times \delta + \sigma}{d \times D \times c_{sat}}$$

where d [cm] is the distance between stretcher and canvas, D [cm² s⁻¹] is the diffusion constant of moisture in air, $c_{sat}(T)$ [g cm⁻³] is the saturation moisture content in air at temperature T [K], α [dimensionless] is the constant of proportionality in the linear relation between the equilibrium moisture content of the materials and the local relative humidity, also called the hygroscopicity factor. δ [cm] is the thickness of the stretcher surface effectively desorbing moisture in the experimental time. ρ [g cm⁻³] is the density of the wood and σ [g cm⁻²] is the surface density of the canvas.

The boundary conditions to solve A2 are 1) that at the beginning the relative humidity is homogeneous in the air pocket, 2) that there is no flow of moisture at $x = 0$ (the pocket is closed on this side) and 3) that the relative humidity at the opposite side of the air pocket is known at each time and has a decreasing exponential behaviour [7].

For the numerical calculations of the profiles from figures 3a and 3b we have used the following values: $D = 0.25$ cm² s⁻¹, $c_{sat}(T) = 22 \times 10^{-6}$ g cm⁻³, $\alpha = 0.15$, $\delta = 0.1$ cm, $\rho = 0.6$ g cm⁻³, $\sigma = 0.04$ g cm⁻², $P = 7.7 \times 10^{-8}$ g cm² s⁻¹ and $d = 0.8$ cm.

APPENDIX B. TWO STEP MODEL FOR THERMALLY INDUCED RH

STEP 1. CALCULATION OF THE NEW GLOBAL ABSOLUTE HUMIDITY LEVEL

To perform the calculation we assume that the painting can be modeled as a closed system that contains a fixed total amount of moisture. In the initial situation the whole system will be at a single constant temperature T^i [°C] and at a single constant relative humidity level RH^i which is expressed as a fractional value between 0 (0%) and 1 (100%). The hygroscopic materials present within the system are treated as a number of sections j . If a single material, such as the canvas, will assume different temperatures along its surface, for each local temperature a separate section is assumed. After constant exposure to a temperature gradient a new temperature distribution will arise, and each section, with its associated dry mass M_j [g] is assumed to reach an individual constant local temperature T_j [°C]. The local temperature shift for a section j is denoted

$$\Delta T_j = T_j - T_i \quad [B1]$$

To model the relation between a local surface relative humidity RH_j [0-1] and the equilibrium moisture content m_j of a section j with dry mass M_j , a simple linear equation is used. The direct proportionality between moisture content and relative humidity is characterised by the hygroscopicity factor α [dimensionless]. The absorption isotherms for canvas, wood and cardboard are known to show a downward shift upon increasing temperatures. To include this dependence a temperature dependent offset term $\beta \times \Delta T_j$ is added, where β [T⁻¹] is the temperature coefficient:

$$\frac{m_j}{M_j} = \alpha RH_j - \beta \Delta T_j \quad [B2]$$

The hygroscopic behaviour of typical cellulose based materials [12] is relatively similar. In our calculations the values for hygroscopicity factor α and temperature coefficient β for all materials have been set to respectively $\alpha = 0.15$ and $\beta = 0.0008$ °C⁻¹.

At the initial condition of equal temperature T and relative humidity RH throughout the system, ΔT_j is zero and equation 2 simplifies to

$$\frac{m_j}{M_j} = \alpha RH^i \quad [B3]$$

Using this equation, the total amount of moisture m_T present in the system, can now be estimated from the initial relative humidity by summing the contributions m_j from all individual hygroscopic sections.

$$m_T = \sum_j (\alpha RH^i) M_j \quad [B4]$$

Note that the relatively small contribution of moisture present in the enclosed air volume is neglected here. Our assumption that the painting can be modelled as a system that is closed for moisture exchange results in a condition for the final local relative humidity values.

$$\sum_j (\alpha RH^i) M_j = m_T = \sum_j (\alpha RH_j^f - \beta \Delta T_j) M_j \quad [B5]$$

We now proceed to calculate the final overall absolute humidity concentration C^f [g m⁻³] that will result from reaching the final temperature distribution. The fact that a homogenous absolute humidity is assumed through the whole enclosed air volume provides a direct relation between the local temperature T_j at a section j , and the local relative humidity RH_j^f . By definition, the relative humidity is the ratio of the actual absolute humidity C^f over the saturation absolute humidity C_{sat} at a given temperature T :

$$RH_j^f = \frac{C^f}{C_{sat}(T_j)} \quad [B6]$$

Substituting equations [5] in [6] it is possible to solve for the final homogeneous absolute humidity C^f that will be attained as a result of all local temperature shifts ΔT_j :

$$C^f = \frac{\sum_j (\alpha RH^i + \beta \Delta T_j) M_j}{\sum_j \left(\alpha \frac{1}{C_{sat}(T_j)} \right) M_j} \quad [B7]$$

STEP 2. CALCULATION OF LOCAL RELATIVE HUMIDITY LEVELS

Substitution of this result in equation 6 can now be used to predict the local relative humidity value RH_x for any local temperature T_x in the system. The relative humidity values are predicted both in the boundary layers at the hygroscopic surfaces, as well as for any other position in the system, for example at a sensor with a certain temperature, hanging free in the enclosed volume.

$$RH_x = \frac{C^f}{C_{sat}(T_x)}$$

[B8]

$$= \frac{\sum_j (\alpha RH^i + \beta \Delta T_j) M_j}{\sum_j \left(\alpha \frac{1}{C_{sat}(T_j)} \right) M_j} \left(\frac{1}{C_{sat}(T_x)} \right)$$

Essentially this equation tells us that moisture will migrate from warm to cold material sections in the painting and that the final relative humidities will depend on the relative masses of the material sections.



This work is licensed under a Creative Commons Attribution - Noncommercial - No Derivative Works 3.0 Licence.

EXTENDING THE USEFUL LIFE OF PAPER - EVALUATION OF THE EFFECT OF VARIOUS PRESERVATION ACTIONS

ANETA BALAŽIČ, ŠPELA HABICHT, MATEJA SMODIŠ, JANA KOLAR AND MATIJA STRLIČ

ABSTRACT

Environmental influences, such as temperature, relative humidity and volatile organic compounds in the atmosphere surrounding an artefact often play a key role in its deterioration. Yet the effects of these parameters are seldom quantified, leading to difficulties in the development of suitable preservation programmes. A recent project, PaperTreat, co-funded by the European Commission's 6th Framework Programme, addresses these issues with respect to paper-based cultural heritage.

Using the Arrhenius approach, data on the extension of the useful life of paper, as achieved by Bookkeeper mass deacidification, cool and cold storage, were obtained. It is demonstrated that deacidified paper is 3.5 times more stable than untreated (pH 6.2), while a decrease of storage temperature by 5 °C increases the longevity of paper by a factor of 2.

INTRODUCTION

The memory of civilisation is inherently linked to the written word which, written on durable materials, has withstood the test of time. For more than five centuries, paper has been the predominant carrier of information and numerous medieval manuscripts bear witness to its durability. However, increasing demand for paper led to several changes in its production in the 19th century. High quality rag fibres were replaced by inferior wood-derived ones. Acid manufacturing technology was introduced which, due to its simplicity and low cost, continued to be used until the end of the 20th century. Otherwise stable paper rapidly degrades in the presence of acids and its decay is further promoted by poor storage conditions and environmental pollutants. As a result, the amount of degraded paper in libraries, archives and museums is reaching enormous proportions.

In order to prolong the usable time of the vast quantities of original materials, paper collections may be treated with alkalis (i.e. deacidified) and/or stored at lower temperatures. While preservation options are known, the lack of well-controlled comparative studies leaves collection keepers hesitant to use them.

Within the PaperTreat project, several European libraries and archives have joined forces with research laboratories to provide information on the extension of the usable life of paper, as achieved by various preservation options. This is a challenging task. Degradation of paper at room temperature is a slow process and although numerous analytical techniques have been used to study the degradation of paper, none is sensitive enough to observe the processes under ambient conditions. In order to estimate the longevity of paper at room temperature, we thus have to resort to determinations of the degradation rate at higher temperatures.

The rate of chemical reaction at a given temperature can be experimentally determined using viscometry by the Ekenstam equation (eq. 1)[1], where t is time and k is the rate constant in $\text{mol}_{\text{bonds}}^{-1} \text{mol}_{\text{monomers}} \text{s}^{-1}$:

$$\frac{1}{DP_t} - \frac{1}{DP_0} = k \cdot t \quad (\text{eq. 1})$$

Interested reader may obtain further information about the Ekenstam equation from readily available works, such as the recently published book 'Ageing and degradation of paper' by Strlič et al. [3]

The rate of degradation under ambient conditions is then obtained by extrapolation of the data to room temperature using the Arrhenius equation (eq. 2), where the rate constant depends on a pre-exponential factor A , activation energy E_a , universal gas constant R ($8.314 \text{ J mol}^{-1} \text{ K}^{-1}$) and temperature (T).

$$k = A \cdot e^{\frac{-E_a}{R \cdot T}} \quad (\text{eq. 2})$$

The approach was experimentally confirmed by Zou et al. for a number of slightly acidic bleached cellulose pulps[2]. The authors showed that the rates predicted from (eq. 2) are in comparatively good agreement with the rates of degradation observed during 22 years of natural ageing. In another experiment, the validity of the Arrhenius equation for oxidation of a bleached sulphate pulp

(pH 7.2) in dry air in a wide temperature interval was demonstrated[3].

This approach is used in the present paper to evaluate and compare the effects of deacidification and storage at lower temperatures on the useful life of paper made from bleached chemical pulp.

EXPERIMENTAL

The paper used in the study was Wifsta Office paper, used previously in a EU co-funded STEP project, CT-90-0100. It is composed of 40% softwood, 60% hardwood fibres, is alum-rosin sized and has a pH of 6.2. The paper was deacidified during the STEP project using the Bookkeeper system (Preservation Technologies, L.P., Cranberry Township PA, USA). The deacidification is based on a liquid-phase process using magnesium oxide (MgO) particles suspended in an organic solvent (perfluoro heptane).

Samples were aged between 90 and 60 °C, at 65% RH, in a Vötsch VC 0020 ageing oven.

Viscometric determinations of the degree of polymerisation (DP) were performed according to the standard procedure[4], using cupriethylenediamine solvent (Carlo Erba). Degree of polymerisation (DP) was calculated from the intrinsic viscosity $[\eta]$ using the equation 3.[5]

$$DP^{0.85} = 1.1 \times [\eta] \quad (\text{eq. 3})$$

RESULTS

Degradation rate constants at room temperature, obtained by extrapolation of data from experiments undertaken at higher temperatures, are associated with considerable error. To improve the quality of predictions, accelerated ageing experiments were performed at seven temperatures. In determinations of degradation rate constants (k), linear correlation coefficients were between 0.976 and 0.998.

	Factor of stabilization
Storage at 15°C	1.9 ± 0.8
Storage at 5°C	8 ± 4
Deacidification and storage at 20°C	3.3 ± 0.9
Deacidification and storage at 15°C	7 ± 3
Deacidification and storage at 5°C	30 ± 17

Table 1. Factor of stabilisation due to deacidification with Bookkeeper (BK) and/or storage at lower temperature, with respect to untreated paper, stored at 20 °C.

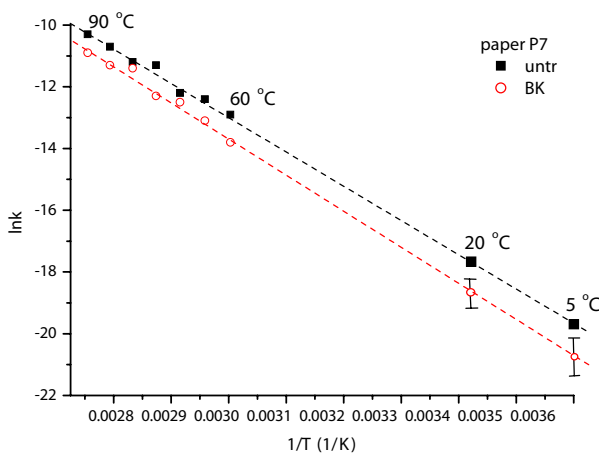

Figure 1. Extrapolation of $\ln(k)$ to 20 °C: ageing of paper P7, either untreated (untr) or deacidified using Bookkeeper (BK) in air at seven temperatures in the interval 60-90 °C. Each of the seven rates of degradation was obtained experimentally by applying the Ekenstam equation to a number of points (DP) determined during an experiment, while the predicted ones (20 and 5 °C) were calculated from the regression parameters. The regression parameters are as follows: untreated; $y = (18 \pm 2) - (1.05 \pm 0.07) \cdot 10^5 \cdot x$, $R = 0.989$ BK; $y = (21 \pm 2) - (1.16 \pm 0.08) \cdot 10^5 \cdot x$, $R = 0.988$

As observed from Figure 1, a reasonably good correlation was obtained between $\ln(k)$ and $1/T$, which allowed us to observe significant differences between predicted degradation rate constants of untreated and of deacidified paper at 20 °C. The ratio of degradation rate constants of deacidified paper and of untreated paper at 20 °C provides a factor of stabilisation, which enables us to establish the efficiency of deacidification compared with storage at lower temperatures (Table 1). It can be observed that the deacidified paper is 3.3 times more stable than the untreated one (pH 6.2), while a decrease of storage temperature by 5 °C increases the longevity of paper by a factor of 1.9. A combined approach, deacidification and storage at low temperature (5 °C), enhanced the stability of paper by a factor of 30.

CONCLUSION

Using the Arrhenius approach, predictions of the extension of the useful life of paper, as achieved by mass deacidification, cool and cold storage were obtained. In the following year, the study will be expanded to include several other papers and other mass deacidification techniques. The results will enable development of the most cost-effective preservation strategies for the decaying collections, and thus contribute to safekeeping and long term access to the endangered written cultural heritage.

ACKNOWLEDGEMENT

The authors gratefully acknowledge the support of the European Community, 6th Framework Energy, Environment and Sustainable Development programme, contract no. SSPI-006584 (PaperTreat). The work is the sole responsibility of authors and does not represent the opinion of the Community. The Community is not responsible for any use that might be made of the data appearing herein.

AUTHORS

Jana Kolar,
National and university library,
Turjaška 1, 1000 Ljubljana, Slovenia,
kolar.jana@gmail.com

Aneta Balažic,
National and university library,
Turjaška 1, 1000 Ljubljana, Slovenia

Špela Habicht,
National and university library,
Turjaška 1, 1000 Ljubljana, Slovenia

Mateja Smodiš,
National and university library,
Turjaška 1, 1000 Ljubljana, Slovenia

Matija Strlič,
University of Ljubljana,
Aškerčeva 5, 1000 Ljubljana, Slovenia

REFERENCES

- 1 A. Ekenstam: "Über das Verhalten der Cellulose in Mineralsäure-Lösungen, II Mittel: Kinetisches Studium des Abbaus der Cellulose in Säure-Lösungen", *Ber.*, 69 (1936) 553-559.
- 2 X. Zou, T. Uesaka, N. Gurnagul: "Prediction of paper permanence by accelerated aging I. Kinetic analysis of the aging process", *Cellulose*, 3 (1996) 243-267.
- 3 M. Strlič, J. Kolar, B. Pihlar: "Methodology and analytical techniques in paper stability studies", in: M. Strlič, J. Kolar (eds.), "Ageing and Stabilisation of Paper", National and University Library, Ljubljana, Slovenia, 2005.
- 4 ISO 5351/1: "Cellulose in dilute solutions- Determination of limiting viscosity number. Part 1: Method in cupri-ethylene-diamine (CED) solution."
- 5 R. Evans, A. F. A. Wallis, "Comparison of Cellulose Molecular Weights Determined by High Performance Size Exclusion Chromatography and Viscometry", in: 4th Int. Symp. Wood Chem., (1987) 201-205.



This work is licensed under a Creative Commons Attribution - Noncommercial - No Derivative Works 3.0 Licence.

WARM FEET AND COLD ART: IS THIS THE SOLUTION? POLYCHROME WOODEN ECCLESIASTICAL ART - CLIMATE AND DIMENSIONAL CHANGES

TONE M. OLSTAD AND ANNIKA HAUGEN

ABSTRACT

The installation of heating systems in the unheated churches in Norway in the first part of the 20th century was, after a period, thought to be the cause of damage to the polychrome wooden objects in the churches. From the end of the 1970s, localised heating in churches has been seen as a way to minimise the climatic impact on the wooden objects. There were however in the 1990s still a number of unanswered questions concerning the climatic stress put on the painted wooden objects.

In the research project *Ecclesiastical Art – Climate and Dimensional Changes* led by The Norwegian Institute for Cultural Heritage Research, the dimensional changes in the surface of the wood were registered. Two of the results from the project were of special interest: the surface of the wood reacted extremely fast, just a few minutes after a change in the environment (relative humidity or temperature). In addition it appeared that relatively larger dimensional changes occurred over distances of one millimetre than in distances around 100 millimetres. A change in the environment (relative humidity or temperature) seemed to cause both swelling and shrinking in the micro distances while the larger distances seemed to be dominated by either shrinking or swelling.

NIKU is in 2007 starting a cooperation with the Institute of Catalysis and Surface Chemistry, Polish Academy of Sciences, in a project with the aim of finding a method of observing reactions in painted wood when exposed to a varying climate. Documentation of changes in the paint layer by laser vibrometry and direct monitoring using acoustic emission will be tried out, complemented by computer modelling. In 2007, Gotland University and NIKU start a project trying to find out whether intermittent heating really has damaged polychrome wooden objects in the churches. Between one and two hundred objects, placed both in heated, unheated and intermittently heated buildings, are planned to be investigated. Hopefully the two projects will create a basis for defining whether the intermittent

heating is damaging the polychrome wooden objects in our churches.

INTRODUCTION

For church authorities in a cold country like Norway, the aim is to keep the users warm and the works of religious art cold. As practitioners within the field of cultural heritage conservation, our approach to climate and dimensional changes in painted wood is based on experience in the field and in the conservation laboratory. We have seen paint flake off as a result not only of unsuitable heating in the churches themselves, but also as a result of a breakdown in the laboratory's humidity control system. This has raised the wish to confirm the link between theory and the "real world". Through cooperation with natural scientists we want to try to find some answers to our questions on climate in churches and climate-influenced dimensional changes in painted wood. Norway's Directorate for Cultural Heritage and NIKU have for many years cooperated with scientists at universities, technical institutions and research institutions. In this paper we present the results of this cooperative work and research, leading to the NIKU publication *Ecclesiastical Art – Climate and Dimensional Changes*, together with the planned work in a Polish-Norwegian project and a Swedish-Norwegian cooperation that started this year. The project partners for the Polish-Norwegian project are the Institute of Catalysis and Surface Chemistry, Polish Academy of Sciences (ICSC PAS) and NIKU. Gotland University and NIKU will work together in the Swedish-Norwegian project. Finally we present our thoughts and questions in a discussion.

CLIMATE IN CHURCHES IN NORWAY

Polychrome (painted) objects made of wood decorate the interiors of most old churches, and Norwegian churches are no exception.

The installation in the early 20th century of heating systems in the previously unheated churches was after a certain period seen to be a threat to the church

art, as damage to polychrome wood was thought to be related to the heating of the buildings. These damages had not been reported previously, in the period starting around the mid-19th century, when some of the churches were locally heated by wood-burning stoves during the hours they were in use in the winter.

Localised heating in churches was thus seen as a way to minimise climatic impact on the wooden objects, and was, from the end of the 1970s, established as the preferred heating system.

In the 1980s the main objective for the climate work – then carried out by the Directorate for Cultural Heritage – was to chart climatic conditions in the churches and to measure the effects of climate on church art in order to implement measures to improve conditions for both the artefacts and the buildings [1]. The measurements confirmed that dramatic changes in relative humidity occurred when churches were heated [1,2]. This has also been observed by, among others, the European project “Friendly heating” [3]. Following a project that confirmed the efficiency of intermittent heating, it is currently recommended that churches in Norway install local heating systems based on radiant heating [4]. Electrical heaters are placed under the benches in the pews, and other radiant heaters are used locally to warm the priest and the organ player when necessary. The heating is activated for the shortest possible period. The Friendly Heating project also improved and refined the localised heating system based on local heaters in the pews and other critical places in the church.

In a cold climate, the intermittent heating method seemed to improve the climate viewed over the whole year, and as a solution was thought to be better than general heating throughout the cold season. In the 1990s, however, a number of questions arose concerning the climatic stress put on the painted wooden objects.

THE PROJECT: CLIMATE AND DIMENSIONAL CHANGES IN PAINTED WOOD

Further work at the Norwegian Institute for Cultural Heritage Research in the 1990s on climate and dimensional changes was based on the need to know how fast the surface of the wood responded to a climatic change. In addition; how big and how long lasting an environmental (relative humidity or temperature) change might be allowed when heating a church, or, put another way: what size and rate

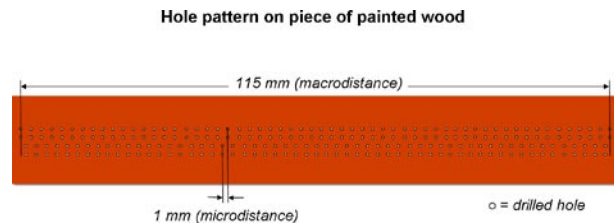

Figure 1. The macro area is 115 mm. It is divided into micro areas. Each micro area is 1 mm and is marked by drilled holes (white dots) in the paint. Two parallel lines of 57 and 58 pairs of holes were drilled. A micro area is the distance between the lines which are formed between the middle of two pairs of drilled holes (white dots). One micro area is the distance between the two black arrows on the figure.



Figure 2. The picture shows the set-up of the climate room with the test piece lying on the workbench. The measurement scale can be seen as a light stripe in the upper part of the plank. The scanner has been moved to the side of the test piece. Photo: Tom-Nils Nilsen

of change were the wooden painted objects able to tolerate before damage occurred?

The project *Climate and dimensional changes in painted wood 1999-2001* [5] used a dummy to test the reaction of painted wood to climatic fluctuations. The test piece was a pine plank measuring 1050 x 215 x 43 mm. It was surface treated on the two largest surfaces in the same way as was standard for medieval wooden painted art. [6]

Of the measurement methods tested in the project, only an optical method based on scanning and data handling was suitable for revealing surface movements over short distances. The method was developed at the Norwegian Building Research Institute. A measurement scale in the form of pairs of holes was drilled into the layer of primer on the test piece. Each pair of holes defined a measurement line and there was about 1 mm between each measurement line. There were 116 measurement lines in all, across a total distance of 115 mm, which delimited the total measurement area (see figure 1). The total measurement area is called the macro area,

while the small areas delimited by the measurement lines are called the micro areas.

While the test piece lay undisturbed in the climate room (see figure 2), the climate changes were carried out in a predetermined series of climate cycles. The climate cycles were based on, and partly simulated, the climatic changes known from heated churches. The tests were carried out over three periods, with several climate cycles in each one. The first cycle had a constant temperature (5°C) and changed the relative humidity from 30% to 80% and then back to 30%. In cycles 2 and 3 the relative humidity was unchanged while the temperature was changed from 5°C to 20°C and then back to 5°C. In cycles 4 and 5 the temperature was again held stable at 5°C and the relative humidity was changed from 30% to 60% and then back to 30%. In cycles 6 and 7 both the temperature and the relative humidity were altered while the water vapour pressure was constant. In cycle 8 the relative humidity was unchanged at 35% while the temperature was altered from 8°C to 22°C. In the last cycle, no. 9, the temperature was held stable at 15°C while the relative humidity was changed from 30% to 80%.

Scanning was initially carried out every 20 minutes, and thereafter every 10 minutes and then every 5 minutes. In each scan 115 micro areas were calculated.

We recorded the movement in the surface of the wood. The discussion of the results is based on the difference between the dimensional changes in the wood and in the paint layer caused by each of the specific materials' interaction with the climate. The dimensional changes in the wood dominate and might cause damage to the paint layer.

The surface of the wood seemed to react extremely fast: a dimensional change was recorded within a few minutes after a change in climate. We do not know the thickness of the wood layer that was rapidly affected. It also appeared that, relatively speaking, considerably larger movements occur in the micro areas than at macro level. At the micro-level, one millimetre area in the materials seemed to be able to expand while the adjacent area contracted.

But is the micro distance important? To what extent will the movements over such small areas influence the paint layer? Our interpretation is that the movement in the micro areas of the wood might stress the paint layer and cause problems for this layer. Is there local compression and strain in millimetre areas in the paint structure?

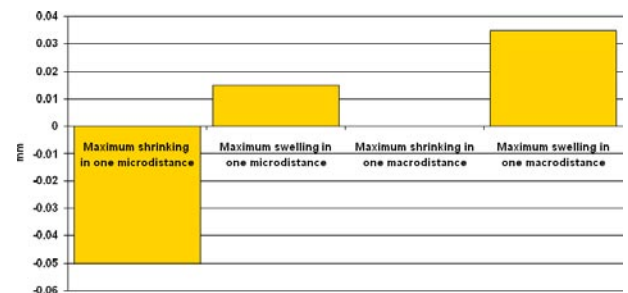

Figure 3. Measured maxima of shrinking and swelling on micro- and macrolevel when the temperature is 15 °C and the relative humidity is raised from 40% to 80%.

We ended up with results that needed confirmation by further work. A measurement method that keeps human participation to a minimum should be used for further work. Since the previous climate may have influenced the project results, it is also extremely important in further work that the test piece is sufficiently stabilised before a climate series is begun.

MICRO MEASUREMENT AREAS

When we worked on the project described above [5] we found that very few had looked at dimensional changes over small areas. Brewer and Forno had used a type of screen or grid measurement technique (moiré fringe analysis) to measure within millimetre areas [7]. Dreiner, Klein and Zillich had used lasers and created a three-dimensional picture of the panel's surface with a reading after each mm step [8]. For the other published projects we looked at, the minimum distance measured was 20 mm and the largest was 400 mm. [9, 10, 11 &12].

RESPONSE TIME

In the 1990s we saw that there was a lack of agreement in the publications regarding response times following climatic change. Dreiner [13] together with Brewer and Forno [7] stated that changes occur quickly after climatic change. Holmberg, together with Klein and Bröker [11, 12, 9] stated that daily changes can be registered, while the *WARP-experiment* indicated that daily fluctuations may be insignificant [10].

There was in general at that time not much in the literature about response time of the outer layer of the wood. When response time was an issue, the responsetimes were usually not described in numbers, but by using expressions such as immediate, instant or fast, or the opposite: late or slow. Brewer and Forno recorded after five minutes a sharp increase in warping in a test panel as a result of climatic change

[7]. Dreiner clearly thinks that it only takes minutes from the imposition of a climatic load until a change in the moisture content in the layer can be registered. He does not quantify the thickness of the layers [13]. The fast, almost immediate, response time is confirmed by later research [14, 15]. Bratasz and Koslowski have found that a change in temperature gives the fastest response in the materials, while the response to RH is slower [16].

In the project *Climate and dimensional changes in painted wood* the response time was shortest at micro-level: under 10 minutes for changes in both relative humidity and temperature. At macro level, however, the response time was shorter for changes in the temperature than for changes in the relative humidity.

It seems as if research during the last 20 years confirms that heating the church even for a short time will influence the objects, at least if the change in temperature, with the consequent change in RH, also reaches the area where the objects are located.

RH AND TEMPERATURE AS ENVIRONMENTAL INFLUENCES

During our work we saw that the wood reacted to changes in both temperature and in RH. The scientists at The Smithsonian Center For Materials Research and Education (SCMRE) considered RH the most important climatic factor. All their tests were done with a fixed temperature and fluctuating RH. Bratasz and Koslowski regard the RH as the most important stress-creating and potentially damaging factor with regard to wooden objects. This is because a change in temperature affects the wood right through, while a change in RH first affects the outer layer of the wood [14]. The stress gradient in wood caused by RH change is discussed also by other scientists. [Among others 17, 13, 18] The stress in the wood may cause it to crack. If the wood cracks the paint will also be damaged. A change in temperature affects the underlying wood, including the surface layer, so a temperature change might cause stress in the paint layer.

Because the RH impact moves inwards through the wood, layer by layer so to speak, the duration of an unwanted climatic condition must be of importance. Short climatic fluctuations will constantly influence the surface of the wood, while the longer the same RH lasts, the thicker the layer of wood that will be influenced by the new climate. However, the

thickness of wood influenced is probably not of importance for the condition of the decorative layer, if the paint is already influenced by movements in the upper layer of the wood.

During the Friendly Heating project the Institute of Catalysis and Surface Chemistry, Polish Academy of Sciences (ICSC PAS) did tests on three different heating episodes and found that the fast changes from 70% to 30% RH lasting from 10 minutes till 24 hours, created unacceptable internal stress in the wooden structure. Rate and duration is of importance for the stress created in the wood, but of what importance is that to the paint layer, as long as the wood does not crack?

Another question is the climatic starting point for the object when exposed to a climatic impact. The scientists at SCMRE did find that there was a significant difference in the allowable RH-fluctuations if the materials were equilibrated to 50% RH in the air, or to a higher or lower RH, when they were exposed to a climatic change. The range of the allowable fluctuation of RH was widest for the materials adjusted to 50% RH. This was later partly confirmed by the research done at ICSC PAS [14].

There always will be gradients of moisture content inside a wooden painted object in a church. It may take months to establish equilibrium moisture content in large masses of wood. How long depends on the thickness of the object. In a church there will constantly be fluctuations in the climate and one climatic situation will most often not last long enough to allow for uniformity of water content to be established throughout the object. Since one can't avoid climatic fluctuations, the aim is to find the allowable microclimatic variations for polychrome wood.

Another problem is that the objects are probably very seldom adjusted to 50% RH when exposed to a change in interior climate.

FUTURE WORK

In the future the following questions need to be answered:

- Is damage in the paint layer related to micro movements in the wood caused by fluctuations in climate?
- Are visible damages in the paint layers related to intermittent heating?
- Is it significant if the values of RH or T rise or fall?

These are simple questions that demand more research to find the more complex answers. There is a need to systematise collected experience, to have more knowledge of materials, and to monitor the wooden polychrome structure while RH/T is being changed. If monitoring is difficult, one possibility is to establish a method to document at micro-level any eventual changes in the structure, before and after a climatic impact.

The first question will be studied in the Polish-Norwegian project *establishing standards for allowable microclimatic variations for polychrome wood* and the second in the Swedish-Norwegian project *Polychrome wood in intermittently heated churches in Scandinavia*.

THE PROJECT "ESTABLISHING STANDARDS FOR ALLOWABLE MICROCLIMATIC VARIATIONS FOR POLYCHROME WOOD"

From 2007 the Institute of Catalysis and Surface Chemistry, Polish Academy of Sciences: ICSC PAS, and NIKU will be partners in a project whose final aim is to establish precisely and quantitatively the variance limits of air parameters, RH and T, which are safe for the painted wooden surfaces. The main idea of the project is to find a method to detect what happens to the painted wood when exposed to varying climate. This method will then be the tool used when trying to define the possible fluctuations the painted wood may sustain without damage. We are looking for a method that enables us to see the earliest stage of the damage process caused by movements in the wood due to climatic changes, which means long before the paint falls off and the damage is irreparable.

The work in the project is based upon the research done at SMRCE in the 1990s by Mecklenburg, Tumosa and Erhardt [19, 20, 21 & 22], the research done by ICSC PAS in the Friendly Heating Project, and the idea that the micro areas are important. Both NIKU [5] and ICSC PAS in their research projects [14] have chosen to use a definition of damage which is based on research carried out by SCMRE, and which states that damage can occur when the structure is loaded beyond the yield point. This definition will also act as the damage definition in the running project.

The main research tool in the project will be direct monitoring of decohesion of the decorative layers

from the wooden support and their mechanical damage using laser vibrometry and acoustic emission, when the object is exposed to certain climatic conditions.

Laser vibrometry will be used to survey the condition of the test piece before and after the climatic tests.

The monitoring of the test pieces during the imposed drying and heating episodes modelled on patterns from real world situations will be done by recording acoustic emissions from the test pieces. Earlier monitoring of acoustic emission done by ICSC PAS has allowed direct tracing of the fracturing intensity in wooden cultural objects exposed to variations in temperature (T) and relative humidity (RH) in their environment [23].

Parallel to the experimental work, there will be computer modelling of mechanical stress appearing at the wood-paint interface. The modelling will be based on the laboratory measurements of physical parameters of materials in the individual layers of the composite polychrome structure.

The measurement methods established in the first laboratory phase of the project is planned to be used on-site in churches in Poland and Norway. This part of the project might be connected to the Swedish-Norwegian project described below.

THE PROJECT "POLYCHROME WOOD IN INTERMITTENTLY HEATED CHURCHES IN SCANDINAVIA"

The Swedish - Norwegian project has been established in cooperation with Gotland University and will start in 2007 as a preliminary study. The main objective is to find out if intermittent heating really has damaged the existing polychrome wooden artefacts. The project plans to study between one and two hundred objects in situ. Materials and painting techniques should preferably be the same for most of the objects in the survey, but in reality it will probably be necessary to note the differences between them.

Information on the conservation and treatment history of the objects will be collected together with information on the building acting as a storage or show case for the objects. The condition for the objects will be defined by the building construction, by historical meteorological data, by heating information and information on the environmental conditions today.

Today's state of the investigated furnishing and wooden objects, will be related to the collected historical information and the climate of today, the aim being to find connections between the climate and the development of damages.

The survey will hopefully create a basis for defining whether it is possible to observe visible damages due to intermittent heating.

DISCUSSION

Wood is a complex material and a wooden painted object comes in many variations. For how many of these objects will research based general rules about suitable preservation climate apply?

Polychrome wooden objects have survived huge climatic impact caused by the natural environment through centuries, by transport from one country to another, from church to church, from church to museum, and between museums, and the impact caused by heating of buildings. The objects still in the churches are in a way objects in use, and have to accommodate to the demands of comfort from people using the churches. The same kind of climatic impact is resisted quite well by some objects, others suffer. The climatic conditions are not the only damaging factor, even if it is important. Maybe further work will show us that we have to make climatic conservation categories that correspond to the structure and materials of the object. Size, shape and paint structure will be parameters in such a division into groups. The practitioner's collection of information from the objects in situ and in museums will have to be used together with the scientists' results from laboratory work.

The climatic history of the objects is also an important parameter for the ideal conservation climate. The same kind of objects, made in the same period, with the same kind of wood and the same painting technique, might have survived better if they had remained in an unsuitable climate in an intermittently heated building, than if they had been moved to a conservation climate for the last few centuries.

ACKNOWLEDGEMENT

The authors would like to thank senior researcher Tom-Nils Nilsen at the Norwegian Building Research Institute (NBI) in Trondheim for developing a measurement method for registering surface movements and to use this to measure how

large and how rapid the dimensional changes are in painted wood in the event of the rapid climatic changes. According to NBI, this was a new optical measurement principle for surface movements in wood, which was developed, tested and utilised in the project *Climate and dimensional changes in painted wood*; a co-operative project between NIKU and NBI.

AUTHORS

Tone Marie Olstad
The Norwegian Institute for Cultural Heritage
Research
P.O. Box 736 Sentrum
NO-0105 Oslo, Norway
tone.olstad@niku.no

Annika Haugen
The Norwegian Institute for Cultural Heritage
Research
annika.haugen@niku.no

LITERATURE:

- 1 Marstein, N. & M. Stein. 1987. Advanced measuring of the climatic conditions in the mediaeval wooden churches in Norway. - ICOM Committee for Conservation, 8th triennial meeting, Sydney. pp. 889 -895.
- 2 Olstad, T. M. 1994. Mediaeval wooden churches in a cold climate – Parish churches or museums? - Roy, A & Smith, P. Preventive Conservation. Practice, Theory and Research. Preprints of the Contributions to the IIC Ottawa Congress, 1994. London. pp. 99 -103.
- 3 Camuffo, D. et al. 2006. Church Heating and the Preservation of the Cultural Heritage. Guide to the Analysis of the Pros and Cons of Various Heating Systems. Milan.
- 4 Olstad, T. M. & A. Haugen. 1997. Klima i stavkirker: Lokal klimatisering av menigheten i Kaupanger stavkirke, Sogndal kommune. - NIKU Fagrapport 004. Oslo
- 5 Olstad, T.M, Haugen, A. & Nilsen, T. N. 2001. Polychrome wooden ecclesiastical art –Climate and dimensional changes. NIKU Publications 110. 24 p
- 6 Surface treatment of the test piece:

Layer	Materials
Topcoat / decorative layer	Boiled linseed oil / English red pigment
Insulation layer	Egg white
Chalk-glue ground	8 coats rabbit glue / water / chalk
Sizing	Rabbit glue / water
Base	Pine

- 7 Brewer, A. & C. Forno. 1997. 'Moiré Fringe Analysis of Cradled Panel Paintings'. - *Studies in Conservation* 42 (1997). - London. pp. 211-230.
- 8 Dreiner, K., Klein, P. & Zillich, I. 1996. 'Investigation into the deformations of Panel Paintings'. - ICOM Committee for Conservation (ICOM-CC). - 11th Triennial Meeting, Edinburgh. 1996. Preprints. - Volume 1. pp. 268 – 270
- 9 Klein, P. & Bröker, F.-W. 1990. 'Investigation into the deformations of Panel Paintings'. ICOM Committee for Conservation (ICOM-CC). - 9th Triennial Meeting, Preprints. Volume 1. Dresden. pp.41-43.
- 10 Ashley-Smith, J., Umney, N. & Ford, D. 1994. Let's be honest – realistic environmental parameters for loaned objects. - Roy, A & Smith, P. Preventive Conservation. Practice, Theory and Research. - Preprints of the Contributions to the IIC Ottawa Congress, 1994. London. s. 28-31.
- 11 Holmberg, J. 1996. Relative Humidity, RH, in historic houses, museums and museum storage rooms, a literature study. - Projektburo EUREKA EU 1383 - PREVENT, Report No. 1 from Swedish partners. Stockholm
- 12 Holmberg, J. G. and B. Kylsberg (1999). Final report on results from measurements at Skokloster palace of: indoor climate; time dependent moisture sorption in old wood; surface deterioration and cupping of old wood; presence of mould; outdoor air filtration. Stockholm. Projektburo EUREKA EU 1383 - PREVENT, Report No. 10 from Swedish partners. Stockholm
- 13 Dreiner, K. 1996. Untersuchungen zur Reduzierung Klimabedingter Belastungen für das Aschaffener Tafelbild. - I: Emmerling, E. & Ringer, C. red. Das Aschaffener Tafelbild. - Arbeitshefte des Bayerische Landesamtes für Denkmalpflege, Band 89. - München. pp. 283-291.
- 14 Bratasz L., Jakiela S., Kozłowski R., 2005 - 'Allowable thresholds in dynamic changes of microclimate for wooden cultural objects: monitoring in situ and modeling'. In 14th Triennial Meeting of ICOM Committee for Conservation, the Hague, 12-16 September 2005: Preprints, James & James, London, vol.2, 582-589.
- 15 Dionisi Vici P., Mazzanti P., Uzielli L., 2006 – 'Mechanical response of wooden boards subjected to humidity step variations: climatic chamber measurements and fitted mathematical models'. *Journal of Cultural Heritage*, Vol 7 (1), 37-48.
- 16 Bratasz L., Kozłowski R., 2005 - 'Laser sensors for continuous monitoring of dimensional response of wooden objects in situ'. *Studies in Conservation*, vol.50, 307-315.
- 17 Uzielli, L. & Casazza, O. 1992. Conservazione dei dipinti su tavola. Firenze 1992.
- 18 Padield, T. www.padfield.org/tim/cfys/
- 19 Mecklenburg, M.F. & C.S Tumosa. 1991. 'Mechanical behavior of paintings subjected to changes in temperature and relative humidity'. - In: Art in Transit. Studies in the Transport of Paintings. - International Conference on the packing and Transportation of Paintings. London 1991. -Washington.
- 20 Erhardt, D. and Mecklenburg, M. 1994. "Relative Humidity Re-examined". - IIC Ottawa Congress. Preprint. London. Roy, A & Smith, P. Preventive Conservation. Practice, Theory and Research. - Preprints of the Contributions to the IIC Ottawa Congress, 1994. London. s.32-37.
- 21 Erhardt, D., Mecklenburg, M., Tumosa, C.S & McCormick-Goodhart, M. 1997. The determination of appropriate museum environment. Bradley, S. - 'The Interface between Science and Conservation'. - British Museum, Occasional paper. Number 116. London. pp 1 53 –163.
- 22 Richard, M., Mecklenburg, M. & C.S. Tumosa. 1998. 'Technical Considerations for the Transport of Panel Paintings'. I: Art in Transit. Studies in the Transport of Paintings. - International Conference on the packing and Transportation of Paintings. London 1991. -Washington.
- 23 S. Jakiela, L. Bratasz, R. Kozłowski, 'Acoustic emission for tracing the evolution of damage in wooden objects', in print, *Studies in Conservation* (2007).



This work is licensed under a Creative Commons Attribution - Noncommercial - No Derivative Works 3.0 Licence.

MUSEUM LIGHTING: ITS PAST AND FUTURE DEVELOPMENT

JAMES DRUZIK AND BENT ESHØJ

ABSTRACT

Light damage to materials has been known for centuries but a serious study of the permanence of colours began earnestly in the 19th century. Throughout the 20th century, researchers sought to quantify the rate of fading and offer techniques conservators could use to slow deterioration rates. This evolved into controlling light exposure to match the needs of both the objects and the viewer. The information has grown and the expertise to use it made more difficult to master. Of all the environmental parameters that effect museum artifacts, light exposure is arguably the most complex and the only one that is essential to the observer. Recent work has suggested that to manage this combined decay/experience parameter a communal approach is needed. That is to say an approach involving the technical contributions of the entire conservation field working collectively. We suggest that such a communal approach is not only logical but allows the conservation field to address more sophisticated topics of perception and visual performance as well as new technologies in illumination.

BACK TO THE PAST

The deleterious effects of the natural environment, and particularly of daylight, were well known in ancient times. Vitruvius tells the story of the notary Faberius who had the walls of his house painted with cinnabar. They started darkening within 30 days and required repainting. Still, it wasn't until the 17th –18th century that natural philosophers began serious study of light and colour, a period that included Isaac Newton's 1670's studies on optics [1], Pierre Bouguer's first attempts to measure light intensity in 1729 [2] and Grotthus, who in 1817, in an amazing insight, noted that light absorbed by a molecule can produce a chemical change.

Artists and colour manufacturers soon began paying attention. According to Padfield and Landi, the first systematic tests of lightfastness were carried out by Dufay about 1733 but the results of his experiments apparently have not survived [3]. Sir Joshua Reynolds was known to have crudely tested his materials in 1772 [4]. George Field, the British colour manufacturer and author, conducted his own

pigment fading tests, beginning as early as 1804. His ten notebooks being ultimately passed on to Henry Charles Newton, one of the original partners of Winsor and Newton, founded in 1832 [5].

All through the early and mid-19th century we consistently find light and air pollution damage to artist materials linked together as threats to be considered seriously. Even Michael Faraday weighed in on these issues during a period when he was the most sought after scientific consultant in England [6] [7].

Setting the tone for our modern concepts of light damage to artist materials were the landmark efforts of A. H. Church, *The Chemistry of Paints and Painting*, and Dr. W. J. Russell and Captain W. de W. Abney's monumental study on the *Action of Light on Watercolours*. Church not only included remarks on the fading characteristics of many pigments then commonly used but he also reports on what others had been doing on the topic – in fact a review of current and past research. His book even includes the remarks of John Ruskin, a man who never seemed to lack an opinion on most matters of aesthetics and preservation, including lighting [4]. But it was Russell and Abney who were left to compile the first truly modern scientific study of light damage [8]. In their highly readable report we encounter strong evidence of light exposure as the cause of fading. They report also on the wavelength specificity of colour change including the potency of different light sources. They use spectrophotometric descriptions of change, the reciprocity law is stated in its modern form, and the effects of light filtration are reported. Their work even extends to the benefits of oxygen-free enclosures. This is perhaps more amazing because they acknowledged lacking a scientific theory of how colour is actually produced and science was still decades away from a quantum theory of atomic structure.

By 1894, with the encouragement of Captain Abney, filtered glass skylights were added to protect the Raphael cartoons in the South Kensington Museum, London. The public seems to have accepted it but a few critics didn't appear to have much sympathy with this new preservation trend. Brommelle tells us that Lord Crawford's reaction in 1923 was less than encouraging:

“One question which ought to be settled was how far there was any justification in using the results of scientific investigations to preserve the colours of museum specimens...Many years ago the Raphael cartoons at the South Kensington Museum had been placed in a fine gallery which was glazed with a nasty lemon-colored glass, which gave one the feeling when entering the room of going into a tomb.”[9]

Crawford doubted the virtue of preservation for future generations, at least at the current technological level, and didn't want to “...sacrifice too much to posterity”.

The first widely read recommendations for museum light intensity appeared in the July 1930 issue of *Burlington Magazine*. Feller presents thirteen sets of recommendations for low, medium and high illumination levels, published throughout the 1930s and 1950s in various journals and books. These thirteen sets, when averaged, come out to 57, 142 and 258 lux, respectively [10]. Except for the highest level of illumination, for materials virtually non-reactive to light, these quantities round off nicely to Thomson's first recommendations (50/150 lux) that appeared in *Studies in Conservation* [11] and were later refined in his book, *The Museum Environment* (50/200 lux) [12]. A partial list of the early authors on these topics through the 1970's is Launer, McLaren, Hanlan, Harrison, Padfield, Robert L. Feller, and Ruth Johnston-Feller. During this period the effects of UV radiation on fugitive and permanent colours were determined and industrial fading standards became widely used in exposure studies in the paint industry and were later adopted in conservation research. Also the vulnerability of large numbers of artists' materials appeared along with more theoretical mechanistic studies [3, 13, 14]. Padfield and Landi stand out in this group since their work continues to be a framework component for many contemporary risk models.

For the next two decades, Garry Thomson and Robert L. Feller became the two most influential voices on the subject of light damage and control, one on either side of the Atlantic Ocean. Feller because of his laboratory's focus on building up the foundations of preventive conservation science using a well-defined research base in the paint and textile industries [15], and Thomson because, up until the first edition of *The Museum Environment* in 1978, no one had written a book on preventive conservation in museums that was comprehensive, yet clear enough for scientists and conservators to use with nearly equal ease.

Museum lighting should not be treated totally *in vitro*, separate from the trends in preventive conservation as a whole. As early as 1844 a handbook by David Boswell Reid on building environmental techniques had been published [16, 17]. It was clear from transcripts during the National Gallery controversies of the early 1850's that Reid's work was known to Sir Charles Eastlake [6, 18] yet Reid's work was apparently never taken seriously enough to be used to improve what was by today's standards an insufferable Gallery environment.

What really produced major ripples on the otherwise placid museum world were the threats of destruction in two world wars, which culminated in the removal of paintings from the National Gallery in London to slate quarries in Manod during the Second World War [19]. Observations of the preservative effect of these stable conditions on canvas and panel paintings suggested to F.I.G. Rawlins (scientific adviser to the National Gallery) that the equal constancy provided by air conditioning would benefit the paintings returned to the National Gallery. Rawlins was also an early worker on colour measurement. In 1955, Rawlins, Robert Organ and R. Sneyers distributed a questionnaire to 64 institutions on indoor climate. Compiled into one comprehensive report, remodeled and extended at ICCROM by Plenderleith and Philippot, it helped create an appetite for more information [20]. After the IIC London Conference on Museum Climatology, the genie could no longer be returned to the bottle and a thirst for more information was sated when Thomson skillfully stepped in and added lighting – which had been weakly represented in the ICCROM report.

Similarly, drawing on a diversity of research from other fields, and filling in where artists' materials presented valuable new research opportunities, Robert Feller and his staff, frequently in partnership with his equally capable wife, Ruth Johnston-Feller, became a fountainhead of applied work that included a large contribution on light damage and its control. Both Feller and Thomson had two properties that guaranteed their celebrity. They wrote early, and they wrote uncompromisingly on scientific issues with simplicity and clarity.

A common over-simplification is that the product of this period in museum lighting research was the “lux laws” supplemented with prohibitions on ultraviolet and infrared radiation. The lighting guidelines were static and immutable. In reality both Thomson and Feller realized that light damage needed to be managed and

could not be completely avoided. But it took a few new voices to introduce concepts of risk management.

From the 1980's onward, an ever larger emphasis began to be placed on examining all elements of museum lighting [21, 22, 23], rendering it practicable in operation [24, 25], and considering other environmental factors [26]. Risk assessment and management thinking showed that rules can be stretched, or violated, for a rational need as long as proper monitoring and documentation is maintained to insure that long-term exposures were controlled. Michalski has recently discussed balancing "situation-specific resolutions" involving object sensitivity, object visibility, lamps, fixtures, rooms, buildings, viewers' reactions to each of these and to the whole, budgets, and finally the influence of everything on the particular museum's goals [27]. At present only the Canadian Conservation Institute, has actually appeared to implement it in their lighting recommendations in the form of higher light levels for enhancing the experience of the museum visitor under a few specific circumstances [28]. Those circumstances are artifacts with low contrast details, dark surfaces, where complex visual searches may be required within a limited time and finally, older viewers. In each of these cases, up to three times the basic light intensity (50 lux) may be employed - ideally compensated by proportional "dark periods". A situation where, for example, older viewers are viewing dark coloured textiles, will according to these recommendations allow $3 \times 3 \times 50 \text{ lux} = 450 \text{ lux}$. To limit the overall light exposure, compensation in exposure time must be applied – again depending on the objects belonging to one of three sensitivity classes. Together with these "dynamic" lighting guidelines CCI recommends lowering – where practical and possible – the UV content of the radiation to max. 10 microwatts per lumen.

At present, we know the vulnerability of materials to light and the spectral energy distribution from light sources. We have instruments to measure light and dosimeters to integrate light exposure. The one major weakness is that our vulnerability classes have often been defined using freshly prepared materials that are more reactive in most cases than identical, aged materials. But since this tends to over-estimate vulnerability it leads to a conservative specification for light levels on objects containing these materials.

INTO THE FUTURE

Michalski has also considered where we need to go in the future and has concluded that:

"The information has grown to the point where it has both revealed the arbitrariness of the simple rules, and outstripped the ability of a conscientious professional to do something reliably better in the time they usually have available".

He calls for collecting and combining this lighting information with newer, cleverer heuristics, into a place and form where it can serve the needs of a "communal risk assessment model" on the Internet [29]. This "communalism" does have its own risks. As a place to warehouse, update and add information that can be accessed by conservators using advanced risk management tools, one can hardly disagree. The data's integrity should be expected to pass built-in quality assurance tests or conform to protocols also described at the same location. Such an environment might also provide a moderated "wikipedia" forum for expanding topics of concern. A few of the topics we would like to see discussed are:

1. Improved understanding and use of colour rendering metrics
2. Response to new lighting technologies that evolve from national or international energy conservation policy
3. Acquisition of a larger number of damage spectra. Emphasis on acquiring sensitivity data on aged and new objects - including anoxic protection.
4. Consensus protocols for human assessments including issues of aesthetics and visual performance.

1. The appearance of an object depends on the spectral power distribution of the light source, the reflection and refraction by the surfaces to be illuminated, and the response of the human visual system [30]. Full adaptation is assumed when making judgments and all intervening fluid media do not contribute. We add to this, that the associated geometries of all three be equally described. The current method for establishing a colour-rendering index for light sources (CRI) by the International Commission on Illumination (CIE 13.3) does not permit the user to "match" a light source to the reflectance properties of surfaces in order to optimize the index value/viewer experience. The index only relates to the properties of the light source in rendering 8 test colours – compared to a reference illuminant of the same colour temperature. Nor does the index permit direct comparison between dissimilar lighting sources. There are strong arguments why one or the other feature might be useful in museum lighting. Rather than assume that solid-state 3 or 4-band sources such as LEDs (Light Emitting Diodes) are

inherently defective or conversely, a panacea, the metric should be offered that answers the question: “Which color palettes can be illuminated that would provide an acceptable quality of light for this source’s spectral power distribution?” The obverse would be “What palettes represent a consensus for unacceptability in colour rendering?”

A manufacturer tends to broadcast the CRI of its light sources when it suits its marketing plan, and even dissuades inquiries about it when it doesn’t. For incandescent lamps this is hardly an issue since they will be compared to a model of an incandescent source of the same color temperature insuring a good score in the colour rendering index. There is no reason to assume manufacturers will change their tactics in the future. Thus we hope for an updated method from the CIE or another party that permits the use of the current CIE 8-colour set, the expanded set (12 or 14 colours), or a true user-supplied set of colours along with different reference comparison.

2. With national energy policies progressively taking firmer and firmer positions on energy conservation, combined with stronger rules on hazardous waste disposal, both the traditional incandescent and fluorescent light sources face significant competition in the future from new light sources – probably with questionable colour rendering properties. We have to prepare for a future with compulsory use of efficient, non-polluting light sources - where the presentation part of museum lighting *must* receive the same attention as the preservation part.

3. We have an ever-growing realization that damage spectra are important and more of them should be measured. Discontinuous spectral sources like LEDs, compared to continuous blackbody illuminants, *at equal luminosity*, will nearly always have spectral energy peaks that exceed the equivalent blackbody or near correlated colour temperature sources (even high CRI fluorescent lamps). If such peaks coincide with damaging wavelengths for a colorant, it will fade faster [31]. We would like this information built into risk models before it is discovered empirically on museum walls. The usefulness of any risk-determining process is limited by the uncertainties of the input information. What conservators repeatedly request of conservation scientists are high quality data. Many of them are content to make important and decisive decisions if that trust is present. Tools that substantially reduce the uncertainties in fading or other colour change mechanisms caused by lighting, directly on objects in a manner that is “virtually” non-destructive, informs the probability that fading

rate is accurate for that object extrapolated to the walls, and improves the accuracy applied to similar objects [32]. Such tools need to be more commonly found in institutions and their results also shared. A user’s group could be established and just as important that the information be shared, inter-laboratory comparisons in the form of round-robin evaluations carried out.

4. Assessing the human response to lighting in a way that is comparable between institutions, researchers, and lighting designers is critical if these techniques will ever serve any “communal” value. Thomson offered the most fundamental rules when he wrote:

- “Adapt your eyes to the illuminant under test
- Look at a set of representative objects under it and accurately memorize their colours,
- Adapt to the reference illuminant,
- Look at the same objects under the second illuminant and compare the colours to the colour in our memory.” [12]

Apart from the physical difficulties in trying to do this, and there are many, what questions should we ask when we “compare”? Or what colour performance test should we apply?

A large and important topic in museum lighting is “visual performance”. This topic is not a new fashion to museum lighting. It is central to the whole reason we exhibit artifacts in the first place and has been embedded in at least one set of guidelines for the last decade [28]. Preservation and presentation is co-equal. Conservation insures the continuance of “generational equity” but not without sharing that equally, in so far as it is possible, between all generations - and doing it well. An object poorly seen is partially wasted, as also the CIE recognized [33]. So a concern for “visual satisfaction” should include sharper concerns for all types of visual quality. This applies to colour differentiation, contrast sensitivity, and viewing of small details, for everyone – young and old - who visits museums. These should stand beside the minimization of disabling glare, visual confusion caused by clutter, and large contrasts in the visual field around the artwork. The variety of simple assessment tools that measure these performances is large and performance measuring techniques designed for pathologies could easily be a part of some lighting selection processes [34].

However, lest we get wrapped up in issues and decide that the “sky is falling” with new fears that are more illusory than real, we should concede that the

human visual system has evolved to accommodate and adapt to a very large range of lighting conditions and the necessity to encumber lighting guidelines with extra requirements need reasonable vetting, for which a communal model may be well suited.

AUTHORS

James Druzik. Senior Scientist,
The Getty Conservation Institute,
1200 Getty Center Dr., Los Angeles,
California 90049, US.
jdruzik@getty.edu

Bent Eshøj. MSc in Conservation,
Head of Department, School of Conservation
The Royal Danish Academy of Fine Arts,
Esplanaden 34, 1263 Copenhagen K, Denmark
be@kons.dk

REFERENCES

- 1 Newton, S.I., *Opticks*. 1979 revision ed. 1730, Mineola, New York: Dover Publications.
- 2 Anon., *Pierre Bouguer*. 2007, Wikipedia.
- 3 Padfield, T. and S. Landi, *The light-fastness of the natural dyes*. Studies in Conservation, 1966. 11(4): p. 181-196.
- 4 Church, A.H., *The chemistry of paints and paintings*. 2nd Edition ed. 1892, London, U.K.: Seeley and Co. Ltd.
- 5 Harley, R.D., *Field's manuscripts: early nineteenth century colour samples and fading tests*. Studies in Conservation, 1979. 24: p. 75-84.
- 6 Select-Committee, *Report on the National Gallery together with the minutes of evidence*, in *Select Committee*. 1850, The House of Commons: London.
- 7 Brommelle, N.S., *Material for a history of conservation*. Studies in Conservation, 1956. II(4): p. 176-188.
- 8 Russell, W.J. and W.d.W. Abney, *Report to the science and art department of the committee of council on education on the action of light on water colours*. 1888: London, United Kingdom. p.77.
- 9 Brommelle, N.S., *The Russell and Abney report on the action of light on water colours*. Studies in Conservation: p. 140-152.
- 10 Feller, R.L., *Control of deteriorating effects of light upon museum objects*. Museum, 1964. 17(2): p. 57-98.
- 11 Thomson, G., *A new look at colour rendering, level of illumination, and protection from ultraviolet radiation in museum lighting*. Studies in Conservation, 1961. 6(2): p. 49-70.
- 12 Thomson, G., *The museum environment*. 2nd Edition ed. Butterworth-Heinemann series in conservation and museology, ed. A. Oddy and D. Lintrum. 1994, Oxford, UK: Butterworth-Heinemann. 293.
- 13 van Beek, H.C.A. and P.M. Heertjes, *Fading by light of organic dyes on textiles and other materials*. Studies in Conservation, 1966. 11(3): p. 123-131.
- 14 Duff, D.G., R.S. Sinclair, and D. Stirling, *Light-induced colour changes of natural dyes*. Studies in Conservation, 1977. 22(4): p. 161-169.
- 15 Whitmore, P.M., ed. *Contributions to conservation science: A collection of Robert Feller's published studies on artists' paints, paper, and varnishes*. 2002, Carnegie Mellon University Press: Pittsburgh. 665.
- 16 Billington, N.S., *A historical review of the art of heating and ventilation*. Journal of the Institution of Heating & Ventilating Engineers, 1955. 23: p. 249-269.
- 17 Reid, D.B., *Illustration of the theory and practice of ventilation: with remarks on warming, exclusive lighting, and communication of sound*. 1844, London, UK.
- 18 Select-Committee, *Report on management of the National Gallery*. 1853: London, United Kingdom.
- 19 Saunders, D. *The National Gallery at War*. in *Materials Issues in art and Archaeology III*. 1992. San Francisco: Materials Research Society.
- 20 Plenderleith, H.J. and P. Philippot, *Climatology and conservation in museums*, in *Climatology and Conservation in Museums*. 1960, ICCROM: Rome. p. 243-289.
- 21 Michalski, S., *Damage to museum objects by visible radiation (light) and ultraviolet radiation (UV)*, in *Lighting: A Conference on Lighting in Museums, Galleries, and Historical Houses*. 1987, The Museums Association, UKIC, and Group of Designers and Interpreters in Museums: Bristol.
- 22 Michalski, S., *Towards specific lighting guidelines*, in *9th Triennial Meeting*. 1990, ICOM Committee on Conservation: Dresden.
- 23 Michalski, S., *Slide rule to determine light damage*, in *Special Publication*. 1994, Canadian Conservation Institute: Ottawa, Canada. p.11.
- 24 Colby, K.M. *A suggested exhibition/exposure policy for works of art on paper*. 1993 [cited].

- 25 Ashley-Smith, J., *Risk assessment for object conservation*. 1st Edition ed. 1999, Oxford, UK: Butterworth-Heinemann. 358.
- 26 Saunders, D. and J. Kirby, *The Effect of relative humidity on artists' pigments*. National Gallery Technical Bulletin, 2004. 25: p. 62-72.
- 27 Michalski, S., *Summary of Issues*, in *Museum Exhibit Lighting 2007: Classic Issues, New Light*. 2007: AIC Annual Meeting, Richmond, Virginia.
- 28 Michalski, S. *The lighting decision*. in *Fabric of an Exhibition, Preprints of Textile Symposium 97*. 1997. Ottawa: Canadian Conservation Institute.
- 29 Michalski, S., *From standards to best practices to risk assessment: where have we been and where are we going?*, in *Museum Exhibit Lighting 2007: Classic Issues, New Light*. 2007: Richmond, Virginia.
- 30 Berns, R.S., ed. *Billmeyer and Saltzman's principles of color technology*. 3rd ed. 2000, John Wiley & Sons, Inc.: New York. p. 247.
- 31 Dirk, C., *Personal Communication*. 2007.
- 32 Whitmore, P.M., X. Pan, and C. Bailie, *Predicting the fading of objects: identification of fugitive colorants through direct nondestructive lightfastness measurements*. Journal of the American Institute for Conservation, 1999. 38: p. 395-409.
- 33 CIE, *Control of damage to museum objects by optical radiation*. 2004, Commission Internationale de L'Eclairage: Paris. p. 30.
- 34 Anon. *Eye examination and testing products*. <http://www.richmondproducts.com> (visited August, 2007)



This work is licensed under a Creative Commons Attribution - Noncommercial - No Derivative Works 3.0 Licence.

INSECT DAMAGE AS A FUNCTION OF CLIMATE

ROBERT E. CHILD

ABSTRACT

Successful insect development is dependent on a number of factors. The availability, quality and quantity of suitable food is a primary one, but other factors such as light, access to undisturbed areas, proximity to other insects of the same species, are others. Fundamental to insect growth, however, are environmental factors of temperature, relative humidity and moisture content of food materials. When a combination of favourable factors leads to increased insect development there is a co-related increase in the damage to materials through eating, despoiling, burrowing and other activities.

Museums and other institutions holding historic and artistic collections have seen a rapid increase in insect damage in the last ten years. Some of the increased attack is due to the banning of powerful pesticides, but other factors have increased the number and variety of insect pests attacking collections. External warming of the environment, through global warming and high internal temperatures in buildings, have energized insect pests to eat and breed faster, thus increasing their propensity to cause more collateral damage. Additionally, the higher ambient temperatures have allowed warm and hot climate insect pests to migrate and thrive in countries and buildings formerly too cold for them to survive.

The changing internal and external climate with increasing temperatures, and its effect on relative humidities and the moisture content in organic material, requires a review of Integrated Pest Management policies in museums to accommodate current changes and future predictions.

INTRODUCTION

Insects are small and secretive. They are usually to be found in tiny microclimates such as under skirtings, behind backboards and embedded in material. The microclimate will not be identical to the environmental conditions measured in the room or building, which if satisfactory, can lead to complacency that insects are not present.

Insects are cold blooded invertebrates; therefore their energy requirements to live, eat and breed

are acquired from external heat sources and from metabolising food. Their moisture requirements are also normally satisfied from the food they eat through the metabolism of the food to generate water, though some will drink liquid water. Most insects prefer conditions of higher temperatures (above 25°C) and higher relative humidities (above 70%RH), although some can tolerate different conditions [2].

The surface area of an insect varies with the square of its radius, while its volume varies with the cube of its radius. Small insects have a very high surface area to body volume and therefore an intimate relationship with their environment, in terms of heat and moisture loss or gain.

Most insect pests in temperate climates have optimum development at temperatures between 20°C and 35°C. At temperatures below 15°C mating is limited, and movement such as flying becomes sluggish. Above 35°C some insects can cool themselves for short periods by evaporating water from their bodies, but in the longer term can die from desiccation. Some insects such as cockroaches, can acclimatise themselves to different temperature norms, but are then killed if subjected to other conditions.

Moisture requirements for insects are satisfied in a number of ways. Some insects, such as silverfish (*Lepisma saccharina*) and furniture beetle (*Anobium punctatum*) obtain their moisture from the food they eat. They therefore require that the food has a suitably high moisture content and this is related to the ambient relative humidity of the surrounding environment and other mechanisms to dampen the food source. A few pest insects such as Australian spider beetle (*Ptinus tectus*) and some cockroaches (*Blatta spp*) require liquid water to survive. A small number of insect pests such as the webbing clothes moth (*Tineola bisselliella*) and biscuit beetle (*stegobium paniceum*) can exist at low relative humidities in water-free areas by processing their foods to produce metabolic water.

HIGH AMBIENT TEMPERATURES

The historic and artistic collections in the UK and elsewhere are subject to higher ambient temperatures than they were twenty years ago. With global warming, annual temperatures are up to 2-3°C higher than in 1980. For example, the 1990's was the warmest decade in the UK since records began [3], and in some areas such as the south west of England, winter frosts are now a rarity. The result of this is that many insect pests are not killed or culled by cold winter conditions, but can survive and breed throughout the year [4]. In some insects, the temporary cessation of growth known as 'diapause' which often helps the insect through the cold months, is bypassed completely in warm conditions, while in others where a different mechanism such as day length triggers the diapause, it may continue to occur.

Indoors, comfort conditions have gradually been raised over the last few decades. In the UK in the 1970's, there was legislation to limit the upper temperature in government buildings to a maximum of 19°C. Now, comfort conditions are normally 22°C or above. Centrally heated galleries and collection storage areas now have high ambient temperatures all year round [5].

Additional heat sources such as conservation heating and dehumidifiers, and solar gain are often present in galleries and storage areas, raising the ambient temperature which is already higher than in previous years from the global warming effect.

EFFECTS OF HIGH AMBIENT TEMPERATURES

Insects live at temperatures that are very close to their surroundings [6]. Higher long-term temperatures cause the following trends:

- higher energy levels.

For most insect pests, temperatures above 15°C up to 35°C cause increasing energy levels that lead to greater mobility, higher feeding rate, higher reproduction rates, greater egg production and lower mortality. These factors can be subdivided as follows:

- greater mobility.

For insects to fly, they normally need high body temperatures. The furniture beetle (*Anobium punctatum*) does not fly readily at temperatures below 25°C and death watch beetle (*Xestobium rufovillosum*) needs temperatures in excess of 27°C to fly. Flying obviously increases the spread of insect attack to other areas.

In general, lower temperatures below 25°C, limits the flying and thus the spread of insect pest adults. Temperatures in this range also limit the mobility of larvae and thus the spread of an infestation outside a localized area.

- increased egg laying.

Insects such as the webbing clothes moth (*Tineola bisselliella*) produce more eggs at higher temperatures. In experiments at 80%RH *Tineola* females laid about 80 eggs at 25°C, but up to 100 eggs at 30°C. Even though eggs can still hatch at 35°C, males quickly (within 2 days) become sterile and all stages are killed in four hours at 41°C [7]. Similar results are seen with a number of other pest insects, with egg production peaking at about 30°C and then dropping off rapidly.

At low temperatures, below about 15°C, reproduction and egg-laying is greatly reduced for many insects and for *Tineola* stops completely below 10°C, even though the insect can still survive.

- fast development times.

The incubation time of eggs of silverfish (*Lepisma saccharina*) ranges from over 40 days at 22°C to under 20 days at 32°C. However, adult's lives are shortened by higher temperatures, so they may live 3 1/2 years at 27°C; 2 years at 29°C but only 1 1/2 years at 32°C. Other insects show similar trends but often around a different norm, thus the furniture beetle (*Anobium punctatum*) develops best at about 22°C and stops at about 28°C.

Webbing clothes moth (*Tineola bisselliella*) was formerly considered to have an annual life cycle, but in recent years, two or even three generations a year have been observed in some indoor UK locations. Similarly, some woodborers such as furniture beetle (*Anobium punctatum*) and death watch beetle (*Xestobium rufovillosum*) appear to be completing their larval stages in appreciably shorter time than in former years.

Very high temperatures above about 40°C will kill most insects at all stages within a few hours [8].

- introduction of new 'warm weather' pests [9].

With higher outside and indoor temperatures, insect pests acclimatised to warmer conditions can thrive in formerly inhospitable locations. The mosquito that can carry malaria now breeds in north Wales and termites had established themselves in the South West of England – though they are now eradicated. Indoors, the brown carpet beetle (*Attagenus smirnovii*) originally from Kenya, is now resident in many London museums, and the Guernsey carpet beetle (*Anthrenus sarnicus*) is relentlessly moving northward towards Scotland. The varied carpet beetle (*Anthrenus verbasci*) was

considered to be the major pest of woolen textiles in Britain 30+ years ago, and webbing clothes moth was not considered to be a pest. Now that situation is reversed [10], though the reason may be due to other factors such as the use of pervasive insecticides such as dieldrin, used in the 1960's in sheep dips.

- other effects.

There may be a number of other temperature effects, that affect the development of certain insects, such as the spread of sex pheromone attractants.

EFFECTS OF LOW AMBIENT TEMPERATURES

Temperatures below accepted human comfort levels of 20-25°C, increasingly affect insect's metabolism, slowing down movement, feeding and reproduction [11]. In many pest insects that are acclimatised to human comfort conditions within buildings, reproduction stops below 15°C and movement virtually ceases below 10°C. Insects in various life stages can survive at these low temperatures. Many lower their internal water content before entering hibernation and generate glycerol in the haemolymph to act as an anti-freeze during these diapausal states. Exceptionally, some insect larvae can freeze solid for short periods without harm.

Temperatures below -10°C will eventually kill all stages of most insects. It is generally accepted that the following temperatures and times will kill all stages:

-18°C to -20°C	will kill in 10-14 days
-25°C	will kill in 7 days
-30°C	will kill in 3 days

This effect is used as one of the principal methods of pest control in many museums [12].

EFFECTS OF VARYING AMBIENT RELATIVE HUMIDITIES

Insects have high moisture contents and owing to their size, have very high surface area to volume ratio, so they can readily lose moisture through evaporation. All insects have a waxy layer on the external cuticle which waterproofs it from loss of body moisture. However, they still lose water through respiration and defecation [13].

Water is obtained by insects in three main ways – by drinking water, as some beetles such as the

Australian spider beetle (*Ptinus tectus*) can do, by ingestion of food with a high moisture content, which is the principal mechanism, or occasionally from the metabolism of dry food to produce chemical water.

Some insects can absorb moisture directly from the air. The firebrat (*Thermobia*), for instance, can accomplish this at RH's down to 45%. But most insects rely on the relationship between high relative humidities and high moisture contents in associated materials. Most insect pests therefore prefer areas of high humidity. The eggs and young larvae of furniture beetle (*Anobium punctatum*) do not survive when the moisture content of the wood is below about 12%, which corresponds to an equilibrium relative humidity above 65%. Some insects, including the webbing clothes moths, can survive at low ambient RH's as they can manufacture water by the metabolism of the wool on which their larvae feed.

EFFECTS OF CLIMATE ON PEST CONTROL TREATMENTS

It is commonly known by pest control technicians that treatments are often not effective at low temperatures (below 20°C) [14]. This is because the low temperature reduces insect activity, so they are less likely to encounter the insecticide and their metabolism is lowered, so they will take longer to die.

High temperatures are known to increase the success of insecticidal treatments including fumigation and space spraying, as the insect's metabolism and activity is increased. Higher temperatures though, will break down chemical insecticides faster. Anoxic 'fumigation', now extensively used in museums, is very temperature dependent and is found to be relatively ineffective at temperatures below 15°C [15].

CONCLUSION

Temperature and relative humidity effects on insect activity are critical to their development and success. Higher ambient temperatures generally increase insect activity and the number of species able to exist in an internal and external environment [16]. Survival parameters for many insect pest species have been studied and are well understood. However, there is much less information about some of the more recently introduced pests, such as the brown carpet beetle. Knowledge of insect biology can be used to provide optimum conditions for the

preservation of vulnerable material from insect attack. Furthermore, the information can be used to enhance the efficacy of pest control treatments.

AUTHOR

Robert .E. Child.
National Museum Wales, Cathays Park,
Cardiff CF10 3NP, UK
robert.child@museumwales.ac.uk

REFERENCES

- 1 Pinniger, D., 2001, New Pests for Old : The Changing Status of Museum Insect Pests in the UK. Proceedings of 2001 : A Pest Odyssey.
- 2 Wigglesworth, V.B., Insect Physiology. Chapman and Hall. 1974.
- 3 Staniforth, S., The impact of climate change on historic libraries. LIBER. 35th Annual General Conference. 2006.
- 4 Godrej, D., The Non-Nonsense Guide to Climate Change. New Internationalist Publications Ltd., 2001.
- 5 Brundrett, G.W., Criteria for Moisture Control. Butterworth & Co., Ltd., 1990.
- 6 Athanassiou, C.G., Kavallieratos, N.G., Tsakiri, J.B., Xyrafidis, S.N., and Vayias, B.J., Effect of Temperature and Humidity on Insecticidal Effect of SilicoSec Against *Ephestia kuehniella* (Lepidoptera:Pyralidae) Larvae. J. Econ. Entomol. 99(4): 1520-1524 (2006).
- 7 Cox, P.D., and Pinniger, D., 2005, Biology, behaviour and environmentally sustainable control of *Tineola bisselliella* (Hummel) (Lepidoptera: Tineidae). Journal of Stored Products Research.
- 8 Strang, T.J.K., A review of published temperatures for the control of pest insects in museums. SPNHC. Collection Forum. 1992. pp.41-67.
- 9 Clark, C.O., The Protection of Animal Fibres Against Clothes Moths and Dermestid Beetles. Journal of the Textile Institute 19., (1928). pp.295-320.
- 10 Halstead, D.G.H., 1975, Changes in the Status of Insect Pests in Storage and Domestic Habitats. Proceedings 1st International Conference on Stored Product Entomology. Savannah USA 1975. pp. 142-153.
- 11 Mullen, M.A., and R.T. Arbogast., Time-Temperature-Mortality Relationships for Various Stored-Product Insect Eggs and Chilling Times for Selected Commodities. J. Econ. Entomol. 72(4).
- 12 Florian, M-L., The Freezing Process – Effects on Insects and Artifact Materials. Leather Conservation News. 1986.
- 13 Busvine, J.R., Insects & Hygiene. The biology and control of insect pests of medical and domestic importance. 1980.
- 14 Mallis, A., Handbook of Pest Control. Eighth edition. Mallis Handbook and Technical Training Company, 1997.
- 15 Valentin, N., Comparative analysis of insect control by nitrogen, argon and carbon dioxide in museum archive and herbarium collections. International Biodeterioration and Biodegradation 32. pp.263-278.
- 16 Intergovernmental Panel on Climate Change. Climate Change 2007 : The Physical Science Basis . 2007.



This work is licensed under a Creative Commons Attribution - Noncommercial - No Derivative Works 3.0 Licence.

Session 2

Measuring the environment

IMPACT OF THE ENVIRONMENTAL CONDITIONS ON THE CONSERVATION OF METAL ARTIFACTS: AN EVALUATION USING ELECTROCHEMICAL TECHNIQUES

VIRGINIA COSTA AND M. DUBUS

ABSTRACT

Metallic coupons were used to evaluate the environmental conditions in several French cultural institutions. They have been exposed inside and outside display cases and evaluated by electrochemical reduction of the surface products formed during the exposure period. The analytical technique allowed the quantitative detection of different compounds. Since deposition of particulate matter accelerates the rate and selectivity of tarnishing, the use of showcases to exhibit artifacts seems to have a beneficial effect, provided that they don't contain any harmful pollutant.

INTRODUCTION

Sources of potentially dangerous environmental conditions are currently being investigated with the aim of minimizing deterioration of cultural artifacts. Because pollutants occur usually in very low concentration inside cultural institutions, their determination is a difficult task, requiring sensitive, relatively expensive and not always accessible techniques. Moreover, even though they are able to detect down to ppb of a given pollutant, this isolated result can hardly define the environment's harmfulness, due to the lack of standard threshold values and to the synergistic effect when several pollutants combine to interact with the material's surface.

Among the methods used to study the impact of the environment on the deterioration of metallic objects, electrochemical evaluation of metallic surfaces previously exposed to a given environment appears to be a very suitable tool. By reducing the products formed on such surfaces, it is possible to resolve the total layer into its major individual chemical constituents. Moreover, the high sensitivity of the technique allows measurement of extremely thin surface films, providing a good estimation of the reaction rate.

This paper presents some examples of the application of electrochemical techniques to evaluate the environmental impact on the conservation of metallic artefacts in different French cultural institutions.

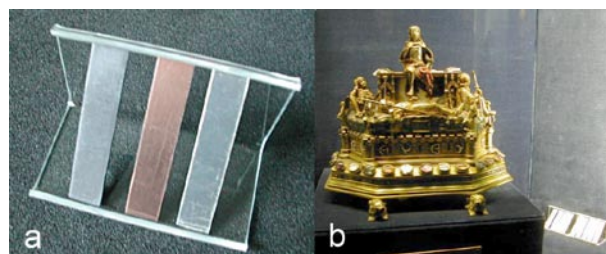

Figure 1. (a) The support structure for silver, copper and lead coupons; (b) The coupon assembly in a showcase.

EXPERIMENTAL

Three metallic sensors (commercial quality, Weber Métaux, Paris) have been used: sterling silver, copper and lead. Measuring 1 x 5 cm, they have been prepared by gently abrading both sides with a glass bristle, so that a homogeneous surface finish is obtained. To estimate the effect of particulate matter on the tarnishing reactions, a Plexiglas® support has been specially designed, so that coupons stay inclined at 45°, presenting one side faced up and the other down (Fig. 1a). Sets containing duplicate coupons of each metal have been placed in 15 cultural institutions, in storage and exhibition rooms, inside and outside display cases (Fig 1b).

A double-compartment cell described elsewhere [1] was used to analyse both sides of the coupons independently. Auxiliary electrodes were platinum wire (counter electrode) and mercury sulphate (MSE, reference electrode). Three different 0.1M solutions have been used as electrolyte: sodium citrate for silver, sodium acetate for copper and sodium sesquicarbonate for lead. Linear sweep voltammetry (LSV) was performed starting from open circuit value (OCP) towards negative values, until around -2VMSE.

RESULTS

The extremely thin tarnish layers formed during exposure were hardly perceptible by eye, but could be easily detected upon electrochemical reduction, showing sharp current peaks. The potential value where each peak starts is characteristic of a given compound,

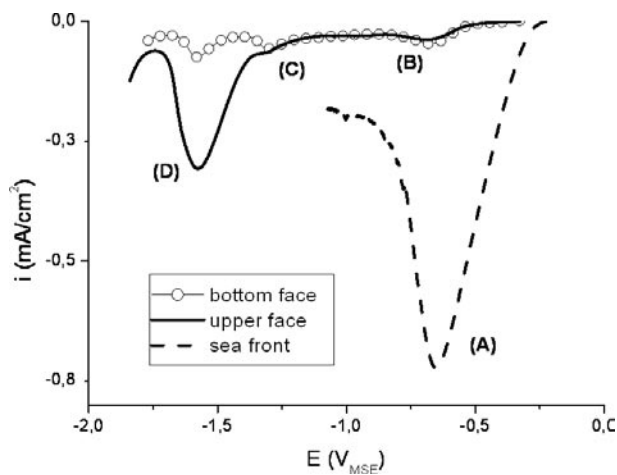

Figure 2. Typical reduction peaks recorded by reducing sterling silver surfaces in 0.1M sodium nitrate, after exposure in different environments.

and the area under the peak corresponds to the charge involved in that reaction, providing an estimate of the amount of product formed. Results shown here are from coupons collected after one year of exposure and summarize the main tendencies.

In the case of sterling silver, four different types of compounds could be identified, depending on the exposure location (Fig. 2). For the coupon kept outdoors, in a courtyard near the sea, a reduction peak starting at ca. -0.2 VMSE (A) can be assigned to silver chloride [1, 2]. Such a product was not found on coupons exposed in the rooms inside the museum, which present three other compounds: silver oxide, silver sulphide and a mixed silver-copper sulphide (reduction peaks B, C and D, respectively [3]. In such cases, comparison of curves recorded for each face of the same coupon shows a remarkably larger amount of this last compound on the upper face, indicating a probable selective corrosion induced by a deposit of particulate matter.

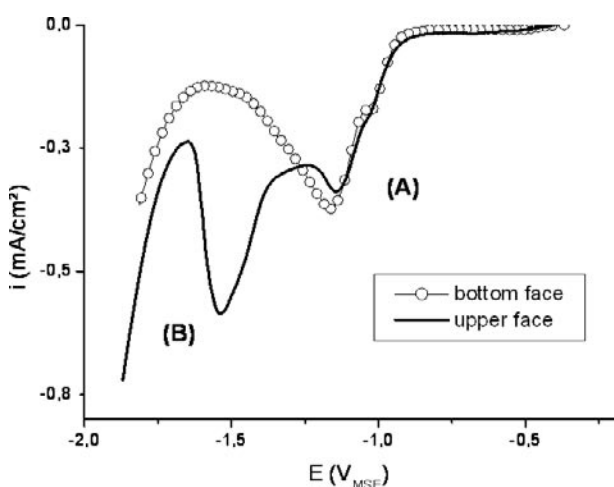

Figure 3. Typical reduction peaks recorded by reducing copper surfaces in 0.1M sodium acetate, after exposure in different environments.

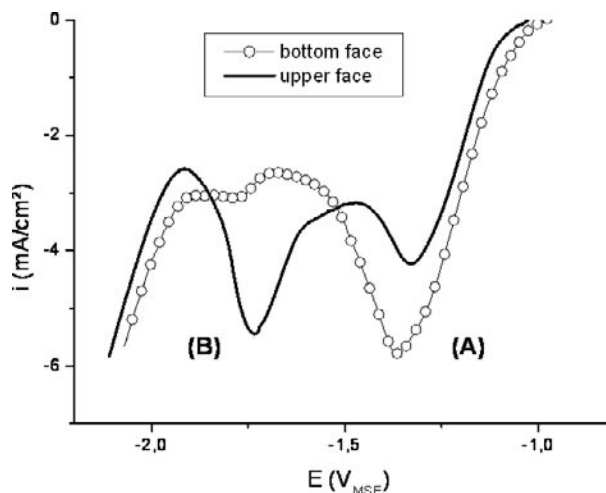

Figure 4. Typical reduction peaks recorded by reducing lead surfaces in 0.1M sodium sesquicarbonate, after exposure in different environments.

LSV performed on copper surfaces generally shows one or two current peaks: the one starting at ca. -0.9VMSE (A), was observed in all cases, while the more negative peak (B) is mostly observed for the upper face of the coupons [2, 4].

Finally, on lead, a similar general behaviour has been observed: a first broad reduction peak starting at ca. -1 VMSE (A), occurring for all coupons, and a second more negative peak (B), observable mostly on the upper side. This last peak was especially very large in wooden cupboards or display cases, and a complementary test confirmed a huge concentration of acetic acid [5], explaining the reactivity of lead.

The rate of tarnishing during the exposure period is estimated from the areas under the reduction peaks. The charge, which is proportional to the amount of material reacting, is shown in figure 5. Results are expressed as charge and not as loss of mass, since a precise identification of the corresponding compound was not possible [3].

Except in the case of lead exposed inside a display case containing high level of acetic acid, which has been found only in two particular situations, data shown in figure 5 are representative of the whole investigation: sterling silver was the less and lead the more reactive surface. Concerning silver coupons, it is worth noticing the high sensibility to particles deposited on the upper side. In fact, coupons exposed inside display cases don't present an important difference in tarnishing for each side, as is the case of those exposed in the room. In contrast, copper surfaces seem to be less sensitive to this effect, but present a general higher reaction rate. Lead is the most reactive of the three metals, certainly due to its natural tendency to form surface

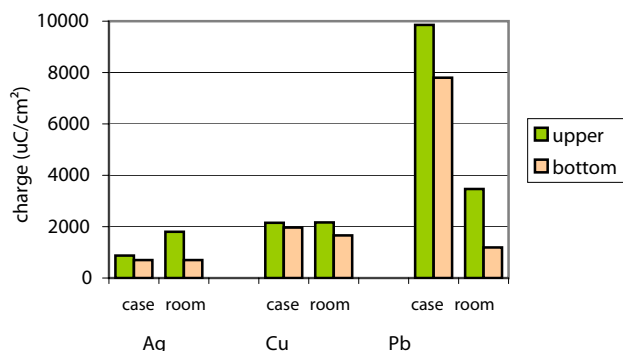

Figure 5. Calculated charge involved in the reduction reactions (approximately corresponding to the amount of compound formed during exposure) for specific situations. The lead values have been divided by ten.

films. Charges calculated on lead coupons are very high in all cases, and assume huge values in specific situations, like confinement inside a cupboard off-gassing organic acid.

The present results should be soon completed by the second measurement campaign, and the final conclusion will allow the definition of priorities concerning the purity of the environment.

CONCLUSIONS

It is possible to evaluate the environmental impact on metallic coupons using electrochemical techniques. Besides the fact that metals promptly react to their environment, expressing synergetic effects, the high sensitivity of the method allows a good qualitative and quantitative determination of surface compounds. The chemical nature of the compounds formed on sterling silver could be determined, supported by results obtained by grazing x-ray diffraction. For copper and lead, even though reduction peaks are sharp, it was not possible to identify the surface compounds.

The three metals react differently depending on the environment, but some general trends can be drawn. In all cases, the amount of product formed on the surface is smaller for coupons exposed inside showcases and for the underside of the coupon. This confirms the harmful effect of particulate matter, probably by absorbing humidity and catalyzing surface reactions. On the other hand, the protection provided by a showcase can be reversed if it contains harmful pollutants, as has been shown in the case of lead confined in cupboards in the presence of high concentrations of acetic acid.

AUTHORS

Virginia Costa.
Conservare, 21 rue des Cordeliers
60200 Compiègne, France.
virginia.costa@gmail.com

M. Dubus.
C2RMF6, rue des Pyramides
75041 PARIS Cedex 01, France.

REFERENCES

- 1 V. Costa, "Impact des conditions environnementales sur la conservation des objets d'art métalliques", Programme National de Recherche en Conservation, MRT 04.40
- 2 J. Guinement, «Etude en laboratoire et sur site, de l'influence de l'interaction entre sulfure d'hydrogène, dioxyde d'azote et chlore sur la corrosion atmosphérique de l'argent et du cuivre», Thèse Université Paris 6, 1985.
- 3 V. Costa, M. Dubus, "Evaluation of the environmental impact on metal artefacts using electrochemistry and grazing incidence XRD", Indoor Air Quality Conference Braunschweig, 2006.
- 4 S.J. Krumbein et al., «Monitoring environmental tests by coulometric reduction of metallic control samples», Journal of testing and evaluation, pp. 357-367, 1989.
- 5 V. Kontozova, personal communication.



This work is licensed under a Creative Commons Attribution - Noncommercial - No Derivative Works 3.0 Licence.

SCREENING EMISSION ANALYSIS OF CONSTRUCTION MATERIALS AND EVALUATION OF AIRBORNE POLLUTANTS IN NEWLY CONSTRUCTED DISPLAY CASES

A. SCHIEWECK, D. MARKEWITZ AND T. SALTHAMMER

ABSTRACT

Emissions of materials currently used for constructing show cases have been studied by means of thermal extraction. The most abundant compounds in the broad spectrum of identified substances were *n*-butyl acetate, ethoxypropylacetate, 1-methoxy-2-propylacetate and ethyl-3-ethoxypropionate. These are used as solvents and additives in coating and adhesive formulations. Additionally, ketoximes, cross-linking agents in neutral curing silicones, were conspicuous compounds. Materials, whose emissions cause adverse health effects, were detected and should be used with caution.

INTRODUCTION

The effects of indoor air pollutants on cultural heritage have been a topic in conservation science for several decades. In the beginning, the focus of most field studies was on inorganic compounds, organic acids and formaldehyde as well as on their risk potential to museum collections [1-4, 19]. Currently, the focal point has increasingly shifted to volatile organic compounds (VOC) and semi-volatile organic compounds (SVOC) in the museum environment as well as to biocides in dust deposits [16, 17]. During these studies it became obvious that the selection of materials for use in the direct surrounding of artefacts has to be carried out with caution in order to keep the emission potential as low as possible to avoid pollution induced damage. Most cultural artefacts are stored and exhibited today in showcases, storage boxes, cabinets and envelopes to preserve them against mechanical and climatic impact. At the request of conservators and exhibition technicians, storage containers and showcases are designed with an air exchange rate reduced to a minimum. The sealed boxes allow the creation of a microclimate, which is independent of the surrounding room and which can be suited to the individual requirements of the specific artefact. However, this construction promotes the accumulation of airborne pollutants. In addition to primary emissions, a number of organic compounds present in indoor air are not in the material

composition from the beginning. They result from secondary reactions during production or use [11, 20]. Construction and packaging materials with a proved low emission potential under normal use and with adequate ventilation (about one air exchange per hour ($n \approx 1 \text{h}^{-1}$)) are not necessarily suitable for the museum environment because of the almost static conditions inside the show cases, their low volume and the often high surface-to-volume ratio. Therefore, it is recommended that materials with a well-known emission potential of hazardous compounds, e.g. wood-based products, wet lacquer finishes and cover fabrics, must be replaced by so-called inert materials like metal, glass and powder coatings. However, a change of material does not inevitably result in a decrease of emissions. This circumstance was shown in preliminary investigations carried out by the authors, where a summed concentration of volatile organic compounds (ΣVOC) of up to 26 mg m^{-3} could be detected. Moreover, complaints about odorous containers and visible changes in the appearance of an exhibit are commonly reported by conservators. However, the prediction of the damage potential of specific construction materials or a specific type of showcase is very difficult without adequate investigation. Thus, it was considered necessary to study emissions from products currently used for the construction of display cases. The paper presents the first results of screening emission analysis with focus on volatile and semi-volatile organic compounds (VOC/SVOC). The preliminary results enable first conclusions about the emission potential of different material classes and their application for museum purposes.

MATERIALS AND METHODS

In close cooperation with manufacturers of furnishings and equipments for museums, products of the following material classes were chosen as representative for screening emission analysis: 1) lacquers/coatings, 2) adhesives/sealants, 3) wood-based products, 4) other construction materials (e.g. aluminium board, ceramic and plastic plates) and 5) textiles. A screening of organic vapour emissions was accomplished using thermal extraction



Figure 1a. Thermal Extractor TE2

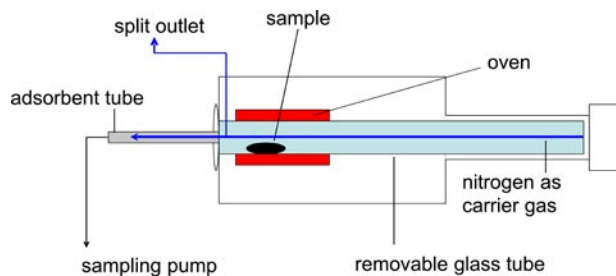

Figure 1b. Thermal Extractor TE2, schematic. Source: Scherer et al. [15]

(Thermal Extractor TE2, Gerstel, Mühlheim an der Ruhr/Germany). This new device allows quick emission measurements and therefore time-efficient and low-cost analysis [14, 15].

The Thermal Extractor TE 2 is shown in Figure 1a. Figure 1b illustrates the mode of operation schematically. The Thermal Extractor consists of an adjustable oven (temperature range: 23°C-350°C) heating a glass tube (length 178 mm, diameter 13.6 mm) with the sample inside. The sample size is limited both by the diameter of the tube and by the heatable length of the oven to a maximum of 73 mm x 10 mm. Nitrogen flows through the glass tube. In normal use, the whole gas flow passes over the adsorbent material (Tenax TA®). At heightened concentrations, the gas can be partly led off through a split outlet. To pass a defined volume over the adsorbent at an open split outlet, a sampling pump is used (FLEC Air Pump 1001, Fa. Chematec) [15]. Substances, which are emitted by the sample are transported with the gas flow over the adsorbent. Operating conditions were chosen according to the emission potential of the material classes. All materials were tested at room temperature (25°C) except lacquers and coatings. Some of these

material class	T[°C]	V [l]	t [min]	n [h ⁻¹]
lacquers/coatings	65	6	40	233
sealants/adhesives	25	1	10	233
wood-based materials	25	6	40	233
construction materials	25	9	60	233
textiles	25	6	40	233

Table 1 Parameters during thermal extraction.

samples showed low emissions at room temperature, so a higher temperature for the whole material class was used (65°C) to detect all generated compounds. Depending on the emission potential of each material class, the sampling volume varied between 1 l and 9 l. Samples with high emissions were sampled with 1 l to prevent contamination during analysis. For low emissive materials, a sampling volume of 6 l – 9 l was necessary to achieve good results. Air sampling was performed with a flow rate of 100 ml min⁻¹ and 150 ml min⁻¹, respectively, so that sampling time ranged from 10 min. to 60 min. Due to the low volume of the glass tube and the high nitrogen gas flow, the air exchange rate is 233 h⁻¹.

After sampling, the Tenax TA® tubes (60/80 mesh, Chrompack) were thermally desorbed (Perkin Elmer ATD 400) into a GC/MS system (Agilent 6890/5970). The compounds were separated on a HP-5 MS column (60 m x 0.25 mm, 0.25 µm). Identification was based on a PBM library search. Mass spectra and retention data were compared with those of reference compounds. All identified compounds were quantified using their own response factors. The limit of detection was < 1 µg m⁻³. All investigation parameters are summarized in Table 1.

RESULTS

Summed VOC(ΣVOC) concentrations varied between 12000 µg m⁻³, emitted by a cellulose nitrate coating on metal, to 2 µg m⁻³, generated by a plastic plate. The emissions of representative materials of each product class are shown on linear (Figure 2a) and logarithmic scale (Figure 2b). Lacquers on metal and on glass, as well as sealants and adhesives, showed the highest emission potential among the investigated product categories. Other construction materials, wood based products and textiles were in general low-emissive unless they had an additional surface treatment. Coatings such as finishings on particle boards or linen coated with adhesives, caused increased emissions. Although the emission potential varied in a wide range between the material classes and the individual products, the dominating gaseous products were similar in each category. For lacquers and coatings, characteristic compounds were identified as carboxylic esters and glycol esters like n-butyl acetate, ethoxypropylacetate, 1-methoxy-2-propylacetate and ethyl-3-ethoxypropionate. These substances are widely used as solvents and additives in coatings (see Figure 3). Further conspicuous compounds were dicarboxylic esters generated by a cellulose nitrate coating. Mixtures

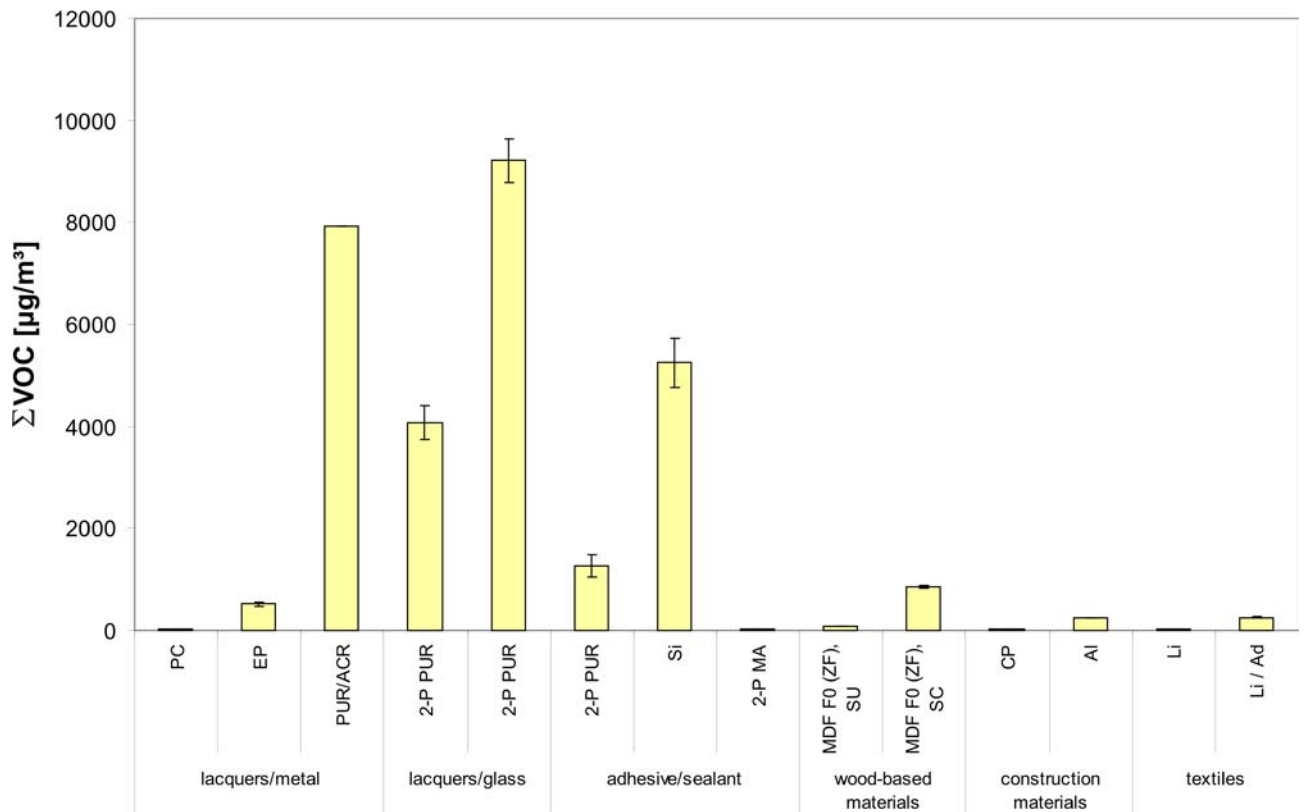

Figure 2a. Total VOC emissions of representative products of each material class, linear scale. Abbreviations: PC: powder coating, EP: epoxy resin, PUR: polyurethane, ACR: acrylic lacquer, Si: silicone, MA: methacrylate, MDF: medium density fibre board, SU: surface uncoated, SC: surface coated, CP: ceramic plate, Al: aluminium composite board, Li: linen; Ad: adhesive; 2-P: two-pack system

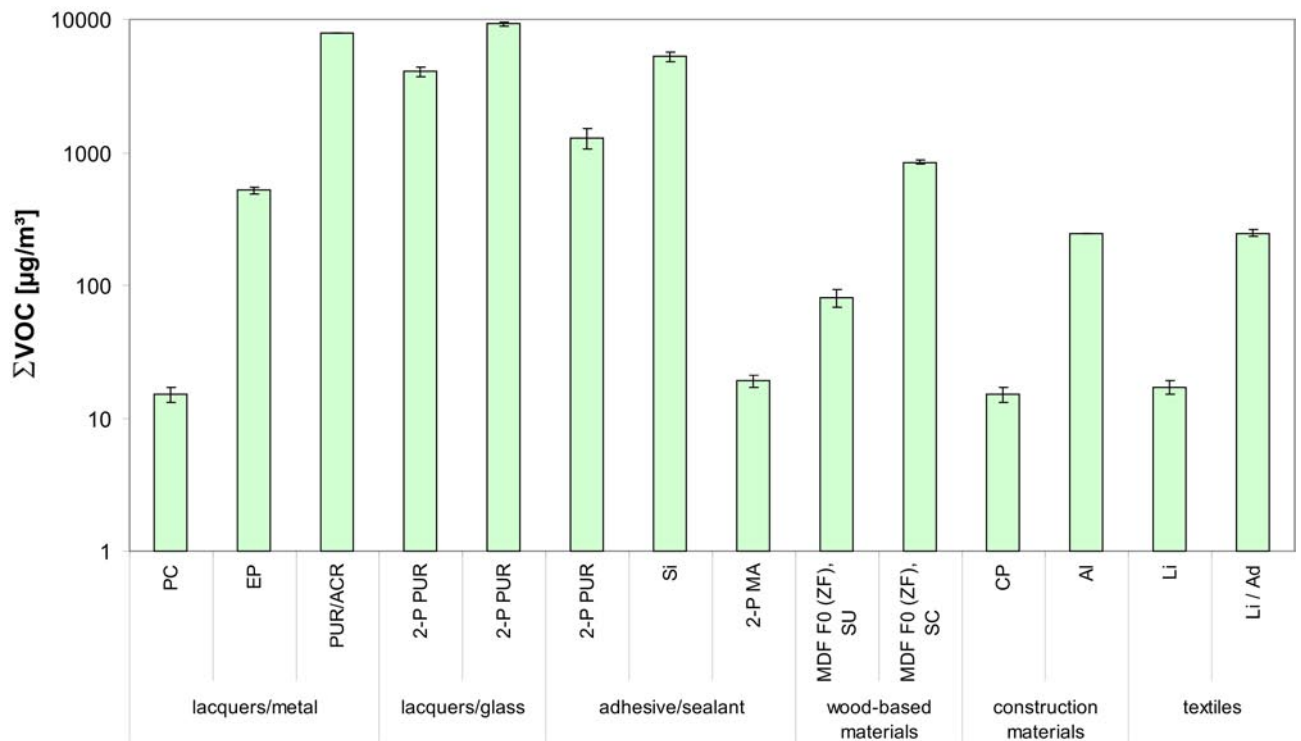

Figure 2b. VOC sum values of representative products of each material class, logarithmic scale. Abbreviations: PC: powder coating, EP: epoxy resin, PUR: polyurethane, ACR: acrylic lacquer, Si: silicone, MA: methacrylate, MDF: medium density fibre board, SU: surface uncoated, SC: surface coated, CP: ceramic plate, Al: aluminium composite board, Li: linen; Ad: adhesive; 2-P: two-pack system

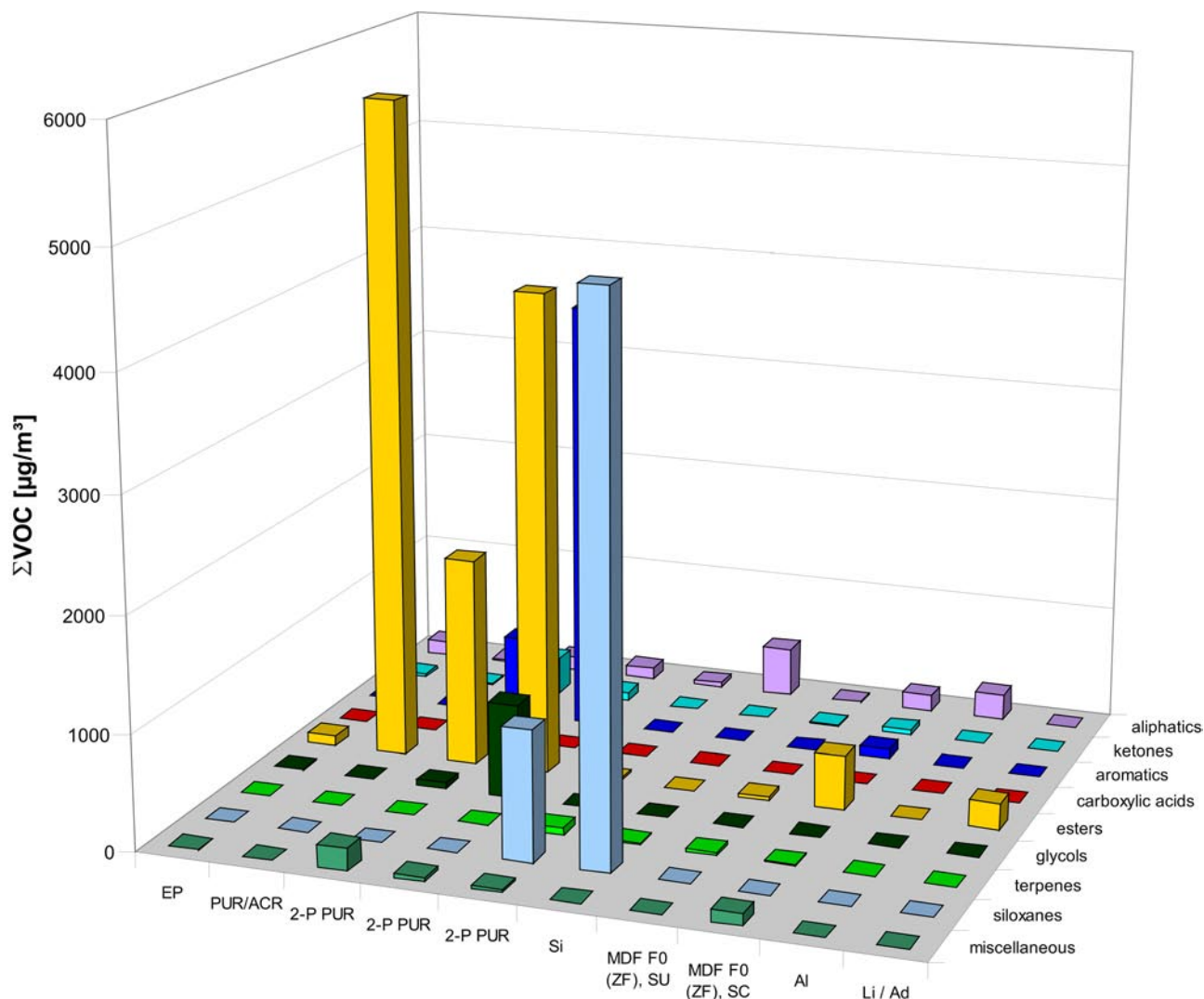

Figure 3. Substance groups identified during screening emission analysis by means of thermal extraction. The figure shows representative materials. Abbreviations: PC: powder coating, EP: epoxy resin, PUR: polyurethane, ACR: acrylic lacquer, Si: silicone, MA: methacrylate, MDF: medium density fibre board, SU: surface uncoated, SC: surface coated, CP: ceramic plate, Al: aluminium composite board, Li: linen; Ad: adhesive; 2-P: two-pack system

of dimethylglutarate, dimethylsuccinate and dimethyladipate are used as filming agents. They can also substitute for chlorinated or hazardous solvents. Moreover, different C3-/C4-benzenes and aromatic compounds such as ethylbenzene and xylene could be identified, which are also used as solvents for a large variety of lacquer systems. An exception among the lacquers was a solvent-free powder coating with nearly no emissions during thermal extraction.

Most of the adhesives and sealants were neutral curing silicones, which are today of industrial importance due to the well-known adverse effects of acid curing formulations on cultural artefacts. Prevalent compounds were therefore siloxanes and ketoximes. Especially siloxanes, which are separated from the polymer matrix, can reach very high concentrations. Ketoximes are fragmentation products, which act as neutral cross linking agents. They decompose during

the curing process by reaction with water vapour and form specific fragmentation products. Characteristic fragmentation products of neutral curing sealants were 2-butanone oxime (MEKO: methylethylketone oxime) and 4-methyl-2-pentanone oxime.

Predominant volatiles from wood-based products were acetic acid and terpenes like alpha-terpineol, borneol and verbenone. Among the construction materials only an aluminium composite board showed an increased solvent emission due to the lacquered cover plates, in comparison to ceramic and plastic plates. Characteristic emissions were the same as detected in lacquers and coatings.

Raw textiles without any surface treatment showed nearly no emissions. The increased emission from a textile treated with an adhesive are attributed to the release of maleine acid di-butyl ester, a key precursor for adhesives (see Figures 2a and 2b).

DISCUSSION

A broad spectrum of substances could be identified by thermal extraction. The most abundant compounds were in general similar to those found in recent studies of building products [8, 10-12, 21]. They were primary fragmentation products of additives and solvent residues released by the polymeric matrix. Alcohols, carboxylic esters as well as glycol esters and glycol ethers are today widely used in formulations of lacquers and sealants. In some adhesives and coatings, substances with adverse health effects could be identified. 2-Butanone oxime (MEKO) is classified as carcinogenic category II and III and teratogenic category III [7, 18]. Moreover, some C3-/C4-benzenes are known to be irritants. Adhesives and sealants with high emissions of MEKO should therefore be avoided for health reasons. Also, product formulations containing large amounts of C3-/C4-benzenes should be used cautiously. Typical emissions from wood and wood-based materials are acetic acid and terpenes. The damage caused by acetic acid is described in the literature [5, 6, 9, 13]. Terpenes are known for their irritant effects on human health. Textiles are mostly used to decorate show cases. If they are untreated, without dyes or additives such as flame retardants, plasticizers, stabilizers and antioxidants, they can be regarded as not hazardous to cultural artefacts.

CONCLUSION AND OUTLOOK

The results of screening emission analysis show that air pollution inside showcases is not limited to formaldehyde, formic acid and acetic acid. In newly constructed display cases, glycol esters, glycol ethers, ketoximes and siloxanes are the most abundant volatile organic compounds emitted by construction materials.

In the future, further investigations of emission behaviour of selected materials will be carried out. In a second step the indoor air quality in complete show cases will be assessed, and finally we will study the influence of secondary emissions, reaction products and possible contributions from the exhibits themselves.

ACKNOWLEDGEMENT

The authors are grateful to all manufacturers who offered raw materials. Financial support by the Stiftung Industrieforschung Köln (Project # S 727) to perform experimental work is gratefully acknowledged. Special thanks from A. Schieweck

go to the Studienstiftung des deutschen Volkes, Bonn, for a dissertation fellowship.

AUTHORS

A. Schieweck, T.Salthammer.
Fraunhofer Wilhelm-Klauditz-Institute (WKI),
Material Analysis and Indoor Chemistry,
Bienroder Weg 54E,
38108 Braunschweig, Germany
alexandra.schieweck@wki.fraunhofer.de

D. Markewitz, T.Salthammer.
University of Applied Sciences
Braunschweig/Wolfenbüttel,
Salzdahlumer Strasse 46/48,
38302 Wolfenbüttel, Germany

REFERENCES

- 1 Ankersmit, H.A., Tennent, N.H., Watts, S.F., 2005. Hydrogen sulfide and carbonyl sulfide in the museum environment – Part 1. Atmospheric Environment 39, 695-707.
- 2 Bears, N.S., Banks, P.N., 1985. Indoor air pollution: effects on cultural and historical materials. The International Journal of Museum Management and Curatorship 4, 9-20.
- 3 Brimblecombe, P., 1990. The composition of museum atmospheres. Atmospheric Environment, 24B (1), 1-8.
- 4 Brimblecombe, P., Shooter, D., Kaur, A., 1992. Wool and reduced sulphur gases in museum air. Studies in Conservation 37, 42-52.
- 5 Brokerhof, A., van Bommel, M., 1996. Deterioration of calcareous materials by acetic acid vapour: a model study. In: Bridgland, J. (Eds.), Proceedings of the 11th Triennial Meeting of the ICOM Committee for Conservation, Edinburgh, Vol. 2, 769-775.
- 6 Dupont, A.-L., Tétreault, J., 2000. Cellulose degradation in an acetic acid environment. Studies in Conservation 45, 201-210.
- 7 Deutsche Forschungsgemeinschaft (Eds.), MAK- und BAT-Werte-Liste 2006. Senatskommission zur Prüfung gesundheitsschädlicher Arbeitsstoffe, Mitteilung 42, WILEY-VCH, Weinheim.
- 8 Girman, J.R., Hodgson, A.T. and Newton, A.S., 1986. Emissions of volatile organic compounds from adhesives with indoor application. Environment International 12, 317-321.

- 9 Grzywacz, C.M. and Tennent, N.H., 1994. Pollution monitoring in storage and display cabinets: carbonyl pollutant levels in relation to artifact deterioration. In: Roy, A., Smith, P. (Eds.), *Preventive Conservation: Practice, Theory and Research*. International Institute for Conservation of Historic and Artistic Works, London, 164-170.
- 10 Salthammer, T., 1997. Emission of volatile organic compounds from furniture coatings. *Indoor Air* 7, 189-197.
- 11 Salthammer, T., 1999. Indoor air pollution by release of VOCs from wood-based furniture. In: Salthammer, T. (Eds.), *Organic Indoor Air Pollutants*, WILEY-VCH, Weinheim, 203-218.
- 12 Salthammer, T., 2004. Emissions of volatile organic compounds from products and materials in indoor environments. *The Handbook of Environmental Chemistry*, Vol. 4, Part F, 37-71.
- 13 Salthammer, T., Siwinski, N., Vogtenrath, W. and Schieweck, A., 2006. Occurrence of formaldehyde and organic acids in the museum environment. In: de Oliveira Fernandes, E., Gameiro da Silva, M., Rosado Pinto, J. (Eds.), *Proceedings of Healthy Buildings 2006*, Lisboa, Portugal, Vol. IV, 283-286.
- 14 Scherer, C., Schmohl, A. and Breuer, K., 2006. Thermal Extraction – a useful supplement to the emission test chamber. In: de Oliveira Fernandes, E., Gameiro da Silva, M., Rosado Pinto, J. (Eds.), *Proceedings of the Healthy Buildings*, Lisboa 4-8 June, Vol. IV, 29-33.
- 15 Scherer, C., Schmohl, A., Breuer, K., Sedlbauer, K., Salthammer, T., Schripp, T., Uhde, E. and Wensing, M., 2006. Praktische Erfahrungen mit Thermoextraktion als Schnelltestmethode für die Emissionsuntersuchung von Bauprodukten und Kunststoffmaterialien. *Gefahrstoffe - Reinhaltung der Luft* 66, 87-93.
- 16 Schieweck, A., Lohrengel, B., Siwinski, N., Genning, C., Salthammer, T., 2005. Organic and inorganic pollutants in storage rooms of the Lower Saxony State Museum Hanover, Germany. *Atmospheric Environment* 39, 6098-6108.
- 17 Schieweck, A., Delius, W., Siwinski, N., Vogtenrath, W., Genning, C., Salthammer, T., 2007. Human exposure to organic and inorganic biocides in the museum environment. *Atmospheric Environment* 41, 3266-3275.
- 18 TRGS - Technische Regeln für Gefahrstoffe, Ausgabe 10/2006.
- 19 Thomson, G., 1986. *The museum environment*. Butterworths series in conservation and museology, 2nd edition, Butterworth-Heinemann Ltd., London.
- 20 Uhde, E. and Salthammer, T., 2007. Impact of reaction products from building materials and furnishings on indoor air quality – A review of recent advances in indoor chemistry. *Atmospheric Environment* 41, 3111-3128.
- 21 Wilke, O., Jann, O. and Brödner, D., 2003. *Untersuchung und Ermittlung emissionsarmer Klebstoffe und Bodenbeläge*. Umweltbundesamt, Texte 27/03, Berlin.



This work is licensed under a Creative Commons Attribution - Noncommercial - No Derivative Works 3.0 Licence.

DOSIMETERS FOR INDOOR MICROCLIMATE MONITORING FOR CULTURAL HERITAGE

M. ODLYHA, C. THEODORAKOPOULOS, D. THICKETT, M. RYHL-SVENDSEN, J.M. SLATER AND R. CAMPANA

ABSTRACT

This paper describes the performance of dosimeters based on the quartz crystal microbalance and demonstrates that measured changes can be correlated with damage to artifacts and with environmental conditions. The work has been performed in the framework of two EC projects where the emphasis has been on damage assessment. In the MIMIC project: [Microclimate Indoor Monitoring for Cultural Heritage Preservation] [EVKV-CT-2000-00040], piezoelectric quartz crystals (PQC) were covered with organic coating. It was the damage to these coatings which was assessed after exposure to a range of environments [1]. The eight-crystal arrays were accommodated in custom built modules and exposed either as passive samplers or as continuous monitoring devices, which recorded weight changes in real time. The Artists' materials, resin mastic varnish and egg tempera, were selected, since mass spectrometric studies had shown that there was a correlation between chemical change and exposure to light [2, 3]. Accelerated light ageing tests of the coated crystals then demonstrated that changes were correlated with changes to the oscillation frequencies of the coated crystals. Furthermore, real time monitoring of exposure to controlled and varied levels of NO₂ and RH provided evidence of a systematic variation in the frequency shifts of the coated crystal arrays [1]. Crystal arrays were also exposed in rooms containing mixed collections in museums, historic houses, and castles, where climate and pollutants, were being monitored [1]. The results obtained from the integration of climate, dosimeter, and chemical data will be discussed in this paper. In the SENSORGAN project (contract no. 022695: Sensor System for Detection of Harmful Environments for Pipe Organs) a lead coating was used. Lead was selected as it was shown in the COLLAPSE project (Corrosion of lead and lead-tin Alloys of Organ Pipes in Europe) [4] that lead was the main constituent of historic organ pipes and that damage occurred as a result of the emission of volatile organic acids from the wood of the wind-chest. Modules containing crystal arrays were exposed to accelerated ageing in laboratory cabinets where levels of acetic acid were monitored. Site monitoring was performed in the organs in two

churches: (1) the Minor Basilica of St. Andrew the Apostle (1611) in Olkusz, Poland (2) St. Botolph without Aldgate (1704) London, England.

INTRODUCTION

This paper describes the use of dosimeters to assess cumulative damage to indoor cultural heritage due to the environment. In the MIMIC project, organic coated piezoelectric quartz crystals were made and their performance in museums and historic buildings was evaluated [1]. The principle of operation of the PQC crystals is that their oscillation frequency depends on the mass of the coating, as related by the Sauerbrey equation [1]. The piezoelectric quartz crystals (PQC) were coated with either resin mastic artists' varnish or egg tempera medium. These coatings were selected since previous mass spectrometric (MS) studies had shown that the degree of oxygenation of the egg lipid components in egg tempera was directly related to the duration of light exposure [2]. MS studies of resin mastic also showed that ageing results in addition of oxygen to the resin compounds, as well as the simultaneous loss of hydrogen [3]. Furthermore, MS studies demonstrated that controlled accelerated light-induced deterioration of mastic coatings on PQC crystals was accompanied by systematic changes in the crystal frequency [5].

Within the framework of the MIMIC project, custom built modules were developed to house arrays of eight coated PQC crystals, which were connected to electronic circuitry for data reduction and storage [1]. This paper presents the results obtained from the integration of climate, dosimeter, and chemical data at various test sites. To facilitate comparison with the dosimeter output, indoor relative humidity (RH) and temperature (T) data were reduced to Time Weighted Preservation Index (TWPI) values [6], and light levels were expressed in accumulated dose, expressed as (klux hours). Pollutant levels of NO₂, NO_x, HONO, HNO₃, O₃ and SO₂ were also expressed in terms of received dosage, in µg/m³ × hours. The environmental and the dosimeter output data are summarised on the website of the MIMIC project (<http://iaq.dk/mimic>) and are available on request [1].

One of the objectives of the current SENSORGAN project is to adapt this piezoelectric based dosimeter to detect the presence of organic acids, which are corrosive to organ pipes [1]. Lead is deposited on the PQC crystals by thermal evaporation. The reason for choosing lead is to provide a coating which will mimic the damage that occurs in lead based organ pipes. Volatile organic acids, predominantly acetic acid, which are generated in the windchest, typically made of oak or pine wood, corrode the lead pipes. In the COLLAPSE project, heavily corroded pipes of 96% lead content were observed in the St Jakobi church (Lubeck, Germany) [4]. The starting point of the SENSORGAN project was to use only lead coating for the PQC crystals, together with lead coupons. The latter are routinely used to monitor display cases in museums. Information on the dosage level [1] of acetic acid which causes damage have been published [7].

EXPERIMENTAL

Crystal arrays (8) were mounted in prepared modules as described elsewhere [1]. Accelerated light ageing at 18,000 lux was performed by exposing modules for periods of 1-16 days [1]. Real time monitoring of the response of egg and resin mastic coated PQC crystals to NO₂ was performed by [1] subjecting them to controlled flows and levels of NO₂ at selected values of RH at ambient temperature. Crystals were also exposed at test sites [1] where environmental conditions (RH, T, pollutants NO₂, NO_x, HONO, HNO₃, O₃, SO₂, light) were recorded [1].

Accelerated ageing was then performed by exposing modules of PQC arrays in cabinets containing blocks of oak and pine wood at 65% RH for extended periods. Levels of acetic acid were monitored using A-D strips [8]. Crystals were also exposed in an old showcase in Kenwood House where levels of acetic and formic acid had been measured by diffusive passive samplers. Test sites included St. Botolph without Aldgate (London) where restoration work had just been completed and the church of St Andrew the Apostle, Olkusz, Poland.

RESULTS OF THE MIMIC PROJECT

SUMMARY OF SELECTED CLIMATE DATA AND DOSIMETER VALUES

Table 1 shows the dates and duration of exposure of the mastic coated PQC arrays in the Petrie Egyptology Museum (PET) (London) together with the dosimeter output expressed as $[\Delta f(\text{Hz})/F(\text{kHz})]$, which is the ratio of the frequency shift to the original coating frequency $[F(\text{kHz})]$. Values of this ratio at PET are

Petrie Museum	Dates		Days	PQC mastic
	Start	End		
PET				$\Delta f(\text{Hz})/$ $F(\text{kHz})$
Exposure 1	2.7.02	12.7.02	10	6.8
Exposure 2	12.7.02	16.7.02	14	10.1
Exposure 3	16.7.02	2.8.02	31	15.3
Exposure 4	2.8.02	7.8.02	36	18
Exposure 5	7.8.02	16.8.02	45	19
Exposure 6	16.8.02	21.8.02	50	18.9
Exposure 7	21.8.02	29.8.02	58	22.1
Exposure 8	29.8.02	11.09.02	71	23.8
Exposure 9	12.9.02	18.09.02	77	22.2
Exposure 10	18.9.02	27.09.02	86	24.4
Exposure 11	27.9.02	09.10.02	99	26.6
Exposure 12	09.10.02	14.10.02	104	30.5

Table 1. dates and duration of exposure of the resin mastic coated PQC arrays in the Petrie Egyptology Museum (PET), London, together with the dosimeter output values.

British Library	Dates		Days	PQC mastic
	Start	End		
BL				$\Delta f(\text{Hz})/$ $F(\text{kHz})$
Exposure 1	17.02.04	23.03.04	35	3.3
Exposure 2	01.04.04	06.05.04	70	7.1
Exposure 3	04.06.04	28.07.04	124	8.1
Exposure 4	30.07.04	06.09.04	162	9.2
Exposure 5	08.09.04	05.10.04	189	8.8

Table 2. dates and duration of exposure of the resin mastic coated PQC arrays in the British Library (BL), London, together with the dosimeter output values.

significantly higher than those obtained on exposure in the selected Reading room in the British Library (BL, Table 2). The environment in BL is air conditioned in contrast to PET, where there is no climate control. Both sites are in a similar location in central London. However, measured indoor concentrations of NO₂ differ; PET has values typically 40-60µg/m³ and BL 10-20µg/m³. The climate data in Table 3 includes these sites and shows that NO₂ dosage levels were higher at PET and probably caused the higher level of dosimeter damage. This is supported by accelerated ageing studies that have shown that NO₂ contributes to the degradation of mastic [1].

Table 3 lists values for selected climate data with dosimeter output values for urban non-conditioned sites, including PET, National Museum of Denmark (NMD_V, NMD_134), Charlottenborg Palace, Copenhagen (CH), Chiswick House, London (CHS), as well as semi-rural non-conditioned sites, including the Alcazar (castle) in Segovia, Spain (ALCMM and ALCC). The dosimeter values together with Time

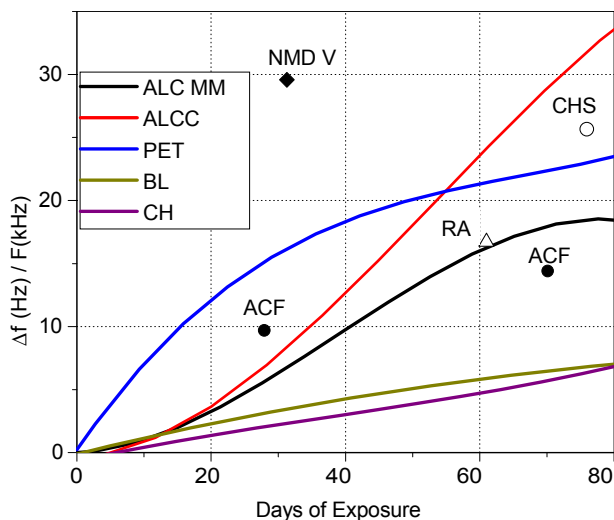

Figure 1. The results from prolonged site exposure of PQC modules were summarised by plotting the dosimeter output values against days of exposure. The data were fitted using regression analysis to provide a “dosimeter map” of the sites monitored [1].

Weighted Preservation Indices (TWPI) [8], light, and pollutant dosages (NO_2 , O_3) are shown. These data represent approximately 30-day exposures. It is observed that the highest dosimeter values and highest coating damage [1] occur at sites where levels of light (NMD_V) and levels of NO_2 (PET) are highest. Lowest dosimeter output values occur for low NO_2 levels at BL and CH where, in addition, the TWPI value is high (indicating both low temperature and low RH) [6]. In the case of ALCMM and ALCC the higher values for O_3 probably contribute to the high value of the dosimeter readings. Between the two latter sites, ALCC has higher levels of light that is reflected in the dosimeter readings [1].

GRAPHICAL SUMMARY OF READINGS FROM DOSIMETERS EXPOSED AT SELECTED TEST SITES

The results from prolonged site exposure of PQC modules were summarised by plotting the dosimeter output value against days of exposure. The data were fitted using regression analysis to provide a “dosimeter map” of the sites monitored (Figure 1). Point values correspond to exposures in NMD_V (entrance hall),

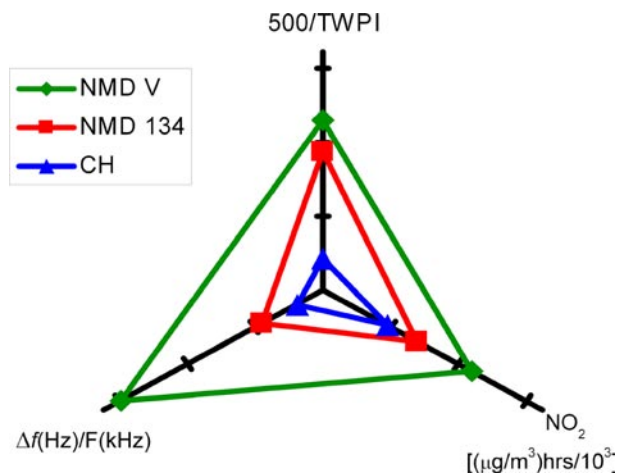

Figure 2. Shows a plot for the calculated Time Weighted Preservation Indices (TWPI), values of NO_2 dosage and dosimeter output values for the 3 sites in Copenhagen in the National Museum of Denmark (entrance hall NMD_V, and room 134 NMD_134), and Charlottenborg Palace, Copenhagen (CH) [1].

1st and 2nd exposures near the statue of David (ACF) (Galleria dell’Accademia, Florence, Italy), as well as in Chiswick House (CHS) and Ranger’s House (RA) (English Heritage, London). It is clearly demonstrated that where conditions are uncontrolled then the damage values are similar to those observed in the Petrie Museum (PET). The air-conditioned site BL showed minimum damage and the non-conditioned site NMD_V showed maximum damage. The similar damage levels shown for CH and BL, may be due to the high TWPI value of CH. Figure 2 shows a plot for the TWPI, NO_2 dosage, and dosimeter output for the 3 sites in Copenhagen (NMD_V, NMD_134 and CH). For CH the high TWPI value (indication of a good quality environment) and lower NO_2 dosage levels than NMD_V gives rise to a lower dosimeter output.[2].

Results from the controlled light ageing measurements relate dosimeter values to duration of exposure. Values greater than 15 [2] were found to be equivalent to 16 days light ageing, less than 15 but greater than 8 were equivalent to 8 days light ageing, and greater than 4 but less than 8 were equivalent to 4 days light ageing. In addition, we calibrated

Start	End	Site	$\Delta f \text{ (Hz)}/F \text{ (kHz)}$	TWPI	Light	O_3	NO_2
03.07.02	12.08.02	NMD_V	29.5	22	4304	12.2	21.9
16.07.02	02.08.02	PET	15.3	47	1.3	2.2	56.4
03.05.03	06.06.03	ALMM	9.6	52	33.5	15.6	4.7
03.05.03	06.06.03	ALCC	10.3	54	82.4	15.7	5.5
20.12.02	21.01.03	CH	3.6	116	2.9	1.1	9.4
03.06.02	03.07.02	NMD_134	9.0	27	17.3	3.4	13.9
03.11.03	05.12.03	CHS	7.3	61	62.4	4.7	31.1
17.02.04	23.03.04	BL	3.3	39	33.6	1.6	9.5

Table 3. values of selected climate data; calculated values of TWPI (years), received dosages of light (kluxhours) and pollutants NO_2 and O_3 [$(\mu\text{g}/\text{m}^3) \times \text{hours} \times 103$], and dosimeter output values for exposure periods shown.

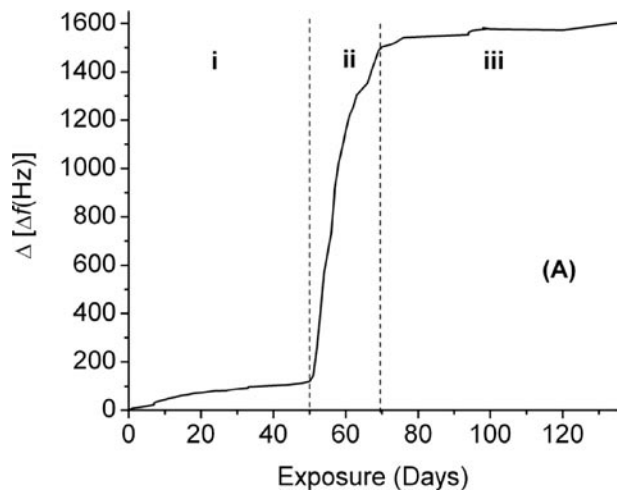

Figure 3. Values are shown for the frequency shifts $[\Delta f(\text{Hz})]$ vs duration of exposure for lead coated PQC crystals in cabinets containing oak and pine blocks and the subsequent changes with higher RH [1].

the response of mastic coated PQC crystals using NO_2 in the dark. Exposure to 10 ppm NO_2 for 14 hrs gave dosimeter output values of about 8. FTIR spectroscopy of coated crystals exposed to various levels of NO_2 showed broadening of the carbonyl absorbance bands. These changes were evaluated at the molecular level by X-ray photoelectron spectroscopy [9]. Overall, four categories of damage classification were defined. Values for dosimeter output according to chemical damage have been allocated as follows: class 4 >15 , class 3 > 8 , class 2 > 4 , and class 1 <4 [2].

Correlation of PQC data, climate, and chemical data (FTIR) together with the effect of accelerated ageing (light and pollutant), to assist damage estimation

The mastic coated PQC crystals showed maximum damage (class 4) in the case of NMD_V (Table 3). FTIR spectra of both mastic and egg tempera samples, from similarly exposed coated strips, showed significant chemical change. The egg tempera samples lost cis-unsaturation completely, whereas there was extreme broadening of the carbonyl peak in mastic. In the ERA

(Environmental Research for Art Conservation) project [10] it was observed by FTIR that unpigmented films (egg only tempera) had a greater response to pollutant ageing than to light ageing. Hydrolysis, leading to the formation of free fatty acids, is more extreme with pollutant exposure (NO_x and SO_2) than light exposure. This was also observed by direct temperature resolved mass spectrometry (DTMS) [11] [2].

RESULTS FROM THE SENSORGAN PROJECT

PREPARATION OF LEAD COATED CRYSTALS AND ACCELERATED AGEING

Lead coatings were applied to piezoelectric quartz crystals using a thermal evaporator specifically designated for the deposition of low vapour pressure metals [12] [2]. The changes that were observed after deposition are summarised in Table 4 [2]. The dosimeter output as for the organic coatings is calculated as described above. In the case of the lead coatings where the formula weight is well defined it is possible to calculate the mass gain and extent of oxidation of the lead metal [2]. For example in Table 4, an initial lead loading of 12,857 Hz (F_0) corresponds to a mass of 8.99 μg [2]. Changes after selected periods of 5-60 days are shown and the change in mass is calculated. Continuous monitoring was performed on canned crystals, where the surface is protected from direct exposure. The PQC crystals were then used uncanned for accelerated ageing and exposure at sites [2].

Humid acidic environments were generated by placing wooden blocks of oak and pine into two cabinets [2]. The increase in acetic acid emission from the oak block and was monitored by the colour change in A-D strips [8]. Acetic acid was readily detected, which indicated that levels were at least ($2500 \mu\text{g}/\text{m}^3$) [13]. Weight increases in lead coupons exposed in the oak containing cabinet were also monitored, and gave values similar to those obtained in the COLLAPSE

PQC lead						
Duration (days)	0	t=5	t=10	t=15	t=30	t=60
F initial frequency (Hz)	12857					
Ft frequency (Hz) at t		13018	13079	13123	13219	13304
Δf (Hz)	0	161	222	266	362	447
$[\Delta f(\text{Hz})/F(\text{kHz})]$	0	12.5	17.3	20.7	28.2	34.8
Mass	Mo (initial)	Mt post-deposition				
Mass (μg) at t	8.99	9.11	9.16	9.19	9.25	9.31
Δm Mass gain (μg)	0	0.12	0.17	0.20	0.26	0.32

Table 4. The changes in dosimeter output values are shown together with mass gain (%) of lead coated PQC crystals after selected periods (5-60 days) of continuous monitoring.

project [14]. The lead coupons exposed in the cabinet with the pine block had a lower mass gain due to the significantly lower emission rate of acetic acid [15]. Consequently the exposed lead coupons showed that the atmosphere generated by oak is more aggressive than that of pine. This supports previous observations on differences on exposure of lead to oak and pine [15] [2]. The RH influences the response of lead in both environments: as RH increases so does the mass gain.

The response of lead coated crystals to the environment in the oak cabinet initially at low RH (30-40%RH) showed a frequency shift of the order of 200-300Hz over several days. When the RH was increased to 50% and then to 65% there was a progressive shift in the rate of change of frequency. In Figure 3 values of the frequency are plotted against time (days). Two sets of crystals are shown: one pair was placed in the oak cabinet on Sept 9th 2006 and the other a month later. This accounts for the initial frequency differences as the first pair had already been exposed to the oak block for one month. From the end of November 2006 the RH in the cabinet was increased. The higher RH promoted in both cases an increase in the rate of frequency shift. Crystal (B5_3) which was inserted in the oak cabinet at RH (65%) showed a change of 1500 Hz over 1-2 days. In terms of the dosimeter output, the value is 110, which exceeds the values observed for changes reported in organic based coatings in the MIMIC project. Two pairs of crystals that had been previously exposed to acetic acid (i.e already tarnished) showed a smaller increase in frequency with increase in RH than those inserted into the cabinet at the later time when the RH had increased. It has been previously observed that RH changes have a greater influence on weight gain of untarnished compared with tarnished lead samples [16][2].

Crystals exposed in the pine cabinet showed a frequency shift of the order of 130 Hz, which was 30% lower than that exposed in the oak cabinet. This difference in behaviour has been previously reported for lead coupons [15]. When the RH in the cabinet was increased to 65%, a further shift of 800Hz occurred. The response in the oak cabinet for a similar period was 1500 Hz. Figure 3 demonstrates the difference in lead coated crystal response between the oak and pine containing cabinets and the subsequent increase with higher RH [2].

Selected coated crystals were placed in the modules and sent for site exposure, in some cases together with lead coupons. The crystal modules allowed free diffusion of air but were protected from

physical damage by a wire gauze screen. Exposure of lead coated crystals in PQC passive sample holders [2] took place initially at Kenwood House, and St. Botolph without Aldgate, both buildings in London. At Kenwood the dosimeters were placed in a showcase where levels of acetic and formic acids had been previously measured [acetic acid 3847 ± 80 $\mu\text{g}/\text{m}^3$, and formic acid 1262 ± 38 $\mu\text{g}/\text{m}^3$]. Exposure at this concentration in an enclosed space for periods of several months has been shown to cause damage to lead objects [7]. This allowed correlation of frequency and/ mass change with significant damage. At St. Botolph without Aldgate the PQC array was placed within the wind chest of the organ, together with lead coupons.

The rate of change [2] in the lead coated crystals in the showcase at Kenwood for a period of one month was similar to that obtained on exposure to 650 ppb acetic acid at 74% RH for 10-12 hours. The dosimeter value was between 100-165. Exposure in the wind chest of the organ at St Botolph gave a slightly lower dosimeter output value between 80-130. In comparison the crystal array placed in the historical organ in Olkusz gave lower values between 14-30.

CONCLUSIONS

Resin mastic PQC crystals have provided dosimeters that are sensitive to light and oxidising agents (NO_2 , ozone), which show a differential response at sites where these conditions vary. Lead coated crystals have provided dosimeters which respond to organic acids (e.g acetic and formic acids). They also show a differential response on exposure to environments where there are different levels of acetic acid. Preliminary site tests indicate that the environment in the organ in St. Botolph shows a high level of change in the crystal array, and there are indications that emissions from the new wood (mainly pine) used in the wind chest are contributing to the damage shown by the lead coupons [2]. In future, both coatings will be used in crystal arrays for monitoring cultural objects in microclimate frames (EC project PROPAIN Improved protection of Paintings during exhibition, storage and transit).

ACKNOWLEDGEMENTS

The MIMIC project acknowledges the support of the EC 5th Framework programme. Thank are due to the MIMIC project team, Dr F. De Santis for measurement of pollutant levels, Dr T. Padfield for assistance and advice with data handling and

Ms K. Matsuoka (British Library) for exposure of dosimeters. SENSORGAN is supported by the EC 6th Framework programme (Priority 8.1 Policy-oriented research: Specific targeted research project contract no. 022695 (<http://goart.gu.se/sensorgan>). The authors acknowledge the support of the coordinator of the SENSORGAN project Dr Carl-Johan Bergsten, Goteborg Organ Art centre, Goteborg University, organ builders Martin Goetz and Dominic Gwynn, (<http://www.goetzegwynn.co.uk>), Dr L. Bratasz and Dr S. Zakiel, Institute of Catalysis and Surface Chemistry, Polish Academy of Sciences as partners in SENSORGAN, and John Neal, Physics Dept., University of Bath, for the thermal deposition of lead.

AUTHORS

M. Odlyha, C. Theodorakopoulos, J. M. Slater and R. Campana.
Birkbeck College, University of London,
Malet St., London WC1E 7HX

D.Thickett.
English Heritage,
1 Waterhouse Square, 138 Holborn,
London EC1N 2ST

M. Ryhl-Svendsen.
The National Museum of Denmark
Department of Conservation
IC Modewegsvej, Brede,
DK-2800 Kgs. Lyngby

REFERENCES

- 1 Odlyha, M., N. Wade, J. M. Slater, Q. Wang, R. Campana, B. Ormsby, M. Rhyl Svendsen, T. Padfield, F. De Santis, V. Smith, L. Bullock, E. S. B. Ferreira, J. J. Boon, K. Pratt "Microclimate Indoor Monitoring: Damage Assessment for Cultural Heritage Preservation" ICOM Preprints Vol 2 (2005) 670-676
- 2 O. F. van den Brink, J. J. Boon, P. O'Connor, M. C. Duursma, R. M. A. Heeren, Matrix-assisted laser desorption/ionisation Fourier transform mass spectrometric analysis of oxygenated triglycerides and phosphatidylcholines in egg tempera paint dosimeters used for environmental monitoring of museum display conditions, *Journal of Mass Spectrometry* 36, Issue 5, (2001) 479-492
- 3 P. Dietemann, M. Kälin, S. Zumbühl, R. Knochenmuss, S. Wülfert, and R. Zenobi, "A Mass Spectrometry and Electron Paramagnetic Resonance Study of Photochemical and Thermal Ageing of Triterpenoid Varnishes" *Analytical Chemistry* 73 (2001) 2087-2096.
- 4 COLLAPSE project [Corrosion of lead and lead-tin alloys of Organ pipes in Europe] <http://goart.gu.se/collapse>
- 5 A. Cavicchioli., M.Sc thesis, University of London (1996)
- 6 J. M. Reilly, M. James, W. Douglas Nishimura, and Edward Zinn. "New Tools for Preservation: Assessing Long-Term Environmental Effects on Library and Archives Collections" Washington, D.C.: Commission on Preservation and Access, (1995).
- 7 J. Tétreault, "Airborne Pollutants in Museums, Galleries and Archives: Risk Assessment, Control Strategies, and Preservation Management", Canadian Conservation Institute (2003) p 23
- 8 Image Permanence Institute, "User's Guide for A-D Strips Film Base Deterioration Monitors," version 1.0 1/95. Image Permanence Institute, Rochester Institute of Technology, 70 Lomb Memorial Drive, Rochester, NY 14623.
- 9 R. H. West, M. Odlyha, K. Pratt, A. Roberts, and S. Hutton, "Monitoring the Environmental degradation of Paint dosimeters used to assess Risk for Fine Art paintings on display by X-ray photoelectron Spectroscopy" *Surface Interface Analysis* 38 (8) (2004) 862-865.
- 10 M. Odlyha, ERA project (EV5V-CT94-0548) presented in special edition of *Thermochimica Acta* "Preservation of Cultural Heritage : Section A: Environmental impact of indoor environments on works of art" *Thermochimica Acta* 365 (2000) 1-53
- 11 O. F. van den Brink, "Molecular Changes in Egg Tempera paint Dosimeters as Tools to Monitor the Museum Environment" Ph.D thesis (2001) (ISBN 90-801704-6-1)
- 12 M. Odlyha, C. Theodorakopoulos, 1st year report SENSORGAN project, <http://goart.gu.se/sensorgan>, Feb. 2007
- 13 Leonardos, G., Kendall, D. and Barnard, N., "Odour threshold determination of 53 odorant chemicals", *Journal of the Air Pollution Control Association* 42 (1997) 141-156
- 14 A. Nikklasson, L-G Johansson, and J-E Svensson, "Influence of Acetic Acid vapour on the atmospheric corrosion of Lead" *Journal of the Electrochemical Society*, 152, (2005) B519-B525

15 Allen,G.C and Black,L., “Role of Organic Acids in Lead Patination “ British Corrosion Journal 35,1, (2000) 39-42

16 Tétreault,J., Sirois,J., and Stamatopoulou,E., “Lead Corrosion in Acetic Acid Environments” Studies in Conservation 43 (1998) 17-32



This work is licensed under a Creative Commons Attribution - Noncommercial - No Derivative Works 3.0 Licence.

THE SURVENIR PROJECT- A DEDICATED NEAR INFRARED INSTRUMENT FOR PAPER CHARACTERIZATION

MATIJA STRLIČ, JANA KOLAR AND DIRK LICHTBLAU

ABSTRACT

Degradation of paper-based collections is a consequence of a variety of factors, from endogenous (paper acidity, lignin content, etc.) to exogenous (pollutants, humidity, etc.). Environmental influences during long-term storage are undoubtedly important parameters. Studies have shown that increased humidity leads to higher rates of degradation of acidic paper, while the influence on mildly alkaline paper is less straightforward. The role of temperature is also crucial – it is possible to calculate how many times the lifetime of paper can be changed if the temperature of storage is increased or decreased by one degree Celsius. Volatile organic compounds (VOCs) are another subject which deserves attention, especially since they are both emitted and absorbed by paper. Studies have shown that such emissions can be substantial.

In any case, long term monitoring of large collections is needed to assess the influence of the storage environment and of the inherent material properties on the ageing behaviour of a collection. For such a task, a simple instrument is needed, which would allow us to survey a collection in a non-destructive, non-invasive and chemical-free manner. In the frame of the SurveNIR project, co-funded by the European Commission 6th Framework Programme, a consortium of research institutions and end-users set out to build a dedicated near infra red (NIR) spectroscopic instrument, which would enable the user to determine a variety of chemical and mechanical properties of paper, including naturally aged paper. The approach will be validated in several European collections in the British Library (London), Victoria and Albert Museum (London), National Archives (The Hague), National Archives (Stockholm), National Museum of Denmark (Copenhagen), National and University Library (Ljubljana), and State Archives of Dubrovnik.

INTRODUCTION

Paper-based documents have long been, and still are, the most important record of human activity. Fortunately, paper is a long-lived material provided that the production technology favours its stability

and provided that it is stored in a favourable environment. However, most of the paper produced between 1850 and 1990 is likely not to survive more than a century or two due to the inherent acidity auto-catalysing the degradation of paper. Cellulose is the most important structural element of paper and it is well-known that the rate of its degradation depends on the pH of its environment [1].

Traditionally, the condition of a paper-based object or a whole collection is assessed visually, and simple physical and chemical tests are performed, such as the folding test [2] or determination of pH of paper using pH-indicator pens. While the folding test is performed in such a way that a paper corner is actually torn away, the pens leave some of the dye used as a pH indicator on the object. Neither of the two tests can be described as non- or micro-destructive. Even determination of paper pH using flat surface electrode, which is probably the most often used methodology in paper conservation workshops, is destructive as an area of paper has to be wetted in order that the measurement can take place at all. After drying, degradation is likely to proceed faster along the wet-dry boundary [3]. In addition to all of the above tests, surveying methods are also highly individual [4]. In any case, surveys are necessary in order to reveal the condition of a collection, the general conservation needs and in order to plan preservation activities.

Mid-IR spectroscopy is widely used to study cultural heritage material. In general, near-IR spectroscopy is gaining in importance in material studies [5-7]. However, aged paper is a complex material and an analytical interpretation of mid-IR spectra is often difficult.

Near-IR spectra often exhibit fewer particular features than mid-IR and Raman spectra. NIR spectra are characterised by overtones and combination vibrations, especially of NH, CH and OH functional groups.

Chemometric analysis of data is a widespread approach to spectral analysis, instead of analytical band assignment [8]. It enables us to compare the whole spectrum (or part of it) with chemical information obtained with the same set of samples. To develop a model for determination of pH of paper, we first

need to determine the pH using traditional methods and compare the obtained data with the spectra of the same set of samples. This approach can be successful under certain conditions [9]. A large enough sample set is needed and the method should be carefully validated. For this purpose, partial least squares (PLS) is often used for correlation of spectral and chemical information [10-12]. From these correlations we can deduce the chemical information for an unknown sample from its spectrum. However, the quality of these correlations depends on a number of factors, among which the quality of spectra and the quality of chemical analytical data play a decisive role.

In this paper, we report on the development of a non-destructive NIR instrument which promises to replace the traditional destructive methods of determination of mechanical properties [13] and pH [14] of historical paper. It should be noted that a developed PLS method is only useful for analysis of the same paper types as was used for building the correlation. A method developed for estimation of pH of rag paper will likely lead to erroneous results if applied to transparent paper.

EXPERIMENTAL

Paper samples were taken from books dated from 1800 till the present. Parts with evident damage due to biodegradation, water-related damage or with damage evidently caused by excessive use were disregarded. Excessively soiled and densely printed samples or laminated, transparent and other specialty papers were not considered either. Margins (3 cm) were cut away to exclude areas degraded due to environmental influences.

Tensile strength (ISO 1924-2:1994) was determined using Zwick Proline Z0.5 TS (load cell nominal force 500 N type II, pneumatic grips, modified jaw faces).

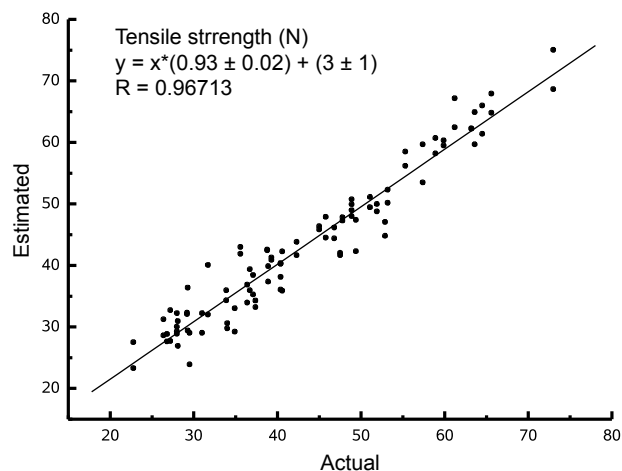

To determine the pH of the paper, cold extraction of microsamples was performed in the following way: 5 μ L of deionized water was added to 20-50 μ g of sample, and left overnight. pH was determined in the extract using a micro-combined glass electrode (MI 4152, Microelectrodes, Bedford, NH).

A Perkin-Elmer Spectrum GX (Waltham, MA) equipped with a 76-mm Labsphere RSA-PE-200-ID (North Sutton, NH) integration sphere coated with Infracore, with a DTGS detector, was used. The reflectance spectra were collected in the interval 6500 - 500 cm^{-1} , 128 scans per sample. Spectra were taken using 4 layers of sample paper.

Spectrum Quant+ software (Perkin Elmer, Waltham, MA), partial least squares analysis (PLS) was used to build correlations and deduce the chemical properties. The quality of correlations was optimized through selection of the most appropriate pretreatment of spectra (derivation, smoothing, etc.) and of the wavenumber intervals used.

RESULTS AND DISCUSSION

NIR spectroscopy in combination with chemometric data evaluation has already been used for evaluation of cellulose degradation during accelerated ageing experiments [7]. The intention of the SurveNIR project is to provide museums, libraries and archival collections with a non-destructive, chemical-free, low-cost surveying tool that would provide more in-depth information than the traditional methods but would also be user-friendly and would not require extensive technical knowledge by the surveyor [15].

Using the PLS approach, we were able satisfactorily to relate NIR spectral information to determinations of mechanical properties [13] and pH [14] of a variety

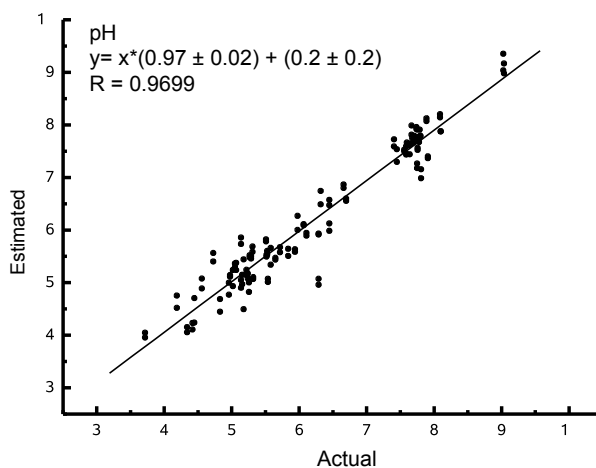

Figure 1. PLS calibrations for estimation of tensile strength [13] and pH [14] of historical paper.

of historical papers (figure 1). This enables us to propose the methodology for rapid determination of the most important information on historical paper needed by conservators and collection managers. In addition to this, we also developed methods for determination of ash content, aluminium content, carbonyl group content, lignin content [14] and tensile strength after folding [13], all from a single spectrum taken in less than a second.

As a part of the dedicated SurveNIR instrument (figure 2), software will be developed which will incorporate the chemometric data evaluation. Chemometry will allow the analysis of a large amount of information – represented by the large number of reflection NIR spectra taken in a collection. The concept of the software will be to allow the user to survey whole collections of paper for chemical and mechanical information, and thus propose actions needed for its optimal preservation.

Case studies in seven collections from European countries in three different types of paper-based collections – museum, library and archive – will be performed to validate the approach.

CONCLUSIONS

A new dedicated NIR instrument has been built, which is designed to enable rapid and safe measurement of spectra from paper. The spectra will be used to describe paper properties of interest, such as pH and mechanical properties. These data are needed in order to decide the most appropriate conservation treatment for the object in question.

In addition, the SurveNIR software will enable the user rapidly to measure spectra of selected items from a collection in order to perform a survey. The traditional techniques, which are destructive and inconclusive, can thus be successfully replaced by this new non-destructive instrument. The SurveNIR instrument will allow us to survey a collection in a non-destructive, non-invasive and chemical-free manner and it will be easy to use by non-professionals.

ACKNOWLEDGEMENT

The authors gratefully acknowledge the support of the European Community, 6th Framework Energy, Environment and Sustainable Development programme, contract no. SSPI-006594 (SurveNIR). The work is the sole responsibility of authors and does not represent the opinion of the Community.



Figure 2. The SurveNIR instrument for non-destructive evaluation of paper chemical and mechanical properties based on chemometric evaluation of NIR spectra.

The Community is not responsible for any use that might be made of the data appearing herein.

AUTHORS

Matija Strlič,
University of Ljubljana, Faculty of Chemistry and
Chemical Technology,
Ljubljana, Slovenia.
matija.strlic@fkkt.uni-lj.si

Jana Kolar,
National and University Library,
Ljubljana, Slovenia

Dirk Lichtblau,
Zentrum für Bucherhaltung GmbH,
Leipzig, Germany

REFERENCES

- 1 M. Strlič, J. Kolar (Eds.): “Ageing and Stabilisation of Paper”, National and University Library, Ljubljana, Slovenia, 2005.
- 2 S. Buchanan, S. Coleman: “Deterioration survey on the Stanford University Libraries Green Library stack collection”, *College and Research Libraries* 48 (1987) 102-147.

- 3 E. Eusman: "Tideline Formation in Paper Objects: Cellulose Degradation at the Wet-Dry Boundary", *Studies in the History of Art* 51, Monograph Series II, National Gallery of Art, Washington, USA, 1995, pp. 11-27.
- 4 J. Taylor, S. Stevenson: "Investigating subjectivity within collection condition surveys", *Museum Management and Curatorship*, 18 (1999) 19-42.
- 5 H. Günzler, H. U. Gremlich (Eds.): "IR spectroscopy. An Introduction", Wiley-VCH, Weinheim, 2002.
- 6 H. W. Siesler, Y. Ozaki, S. Kawata, H. M. Heise (Eds.): "Near-Infrared Spectroscopy. Principles, instruments, Applications", Wiley-VCH, Weinheim, 2002.
- 7 M. Ali, M. A. Emsley, H. Herman, J. R. Heywood: "Spectroscopic studies of the ageing of cellulosic paper", *Polymer* 42 (2001) 2893-2900.
- 8 M. Blanco, I. Villarroya: "NIR spectroscopy: a rapid-response analytical tool" *TRAC* 21 (2002) 240-250.
- 9 G. W. Small: "Chemometrics and near-infrared spectroscopy: Avoiding the pitfalls" *TRAC* 25 (2006) 1057-1066.
- 10 G. R. Brereton (Ed.): "Chemometrics, Data Analysis for the Laboratory and Chemical Plant", Wiley & Sons, Chichester, 2003.
- 11 H. P. J. Garthwaite: "An interpretation of partial least squares" *J. Am. Stat. Assoc.* 89 (1994) 112-127.
- 12 A. Höskuldsson: "Variable and subset selection in PLS regression" *Chemometr. Intell. Lab. Syst.* 55 (2001) 23-38.
- 13 D. Lichtblau, M. Strlič, T. Trafela, J. Kolar, M. Anders: "Determination of mechanical properties of historical paper based on NIR spectroscopy and chemometrics – a new instrument", *Appl. Phys. A* (2007) submitted.
- 14 T. Trafela, M. Strlič, J. Kolar, D.A. Lichtblau, M. Anders, D. Pucko Mencigar, B. Pihlar: "Nondestructive analysis and dating of historical paper based on IR spectroscopy and chemometric data evaluation", *Anal. Chem.* 79 (2007) 6319-6323.
- 15 SurveNIR webpage, <http://www.science4heritage.org/survenir/>



This work is licensed under a Creative Commons Attribution - Noncommercial - No Derivative Works 3.0 Licence.

DETERMINATION OF RESPONSE RATES OF WOODEN OBJECTS TO FLUCTUATING RELATIVE HUMIDITY IN HISTORIC PROPERTIES

BARRY KNIGHT AND DAVID THICKETT

ABSTRACT

The response of a piece of historic furniture exposed to natural fluctuations in the ambient temperature and relative humidity (RH) has been determined, using a minimally intrusive displacement sensor. Changes in the width of a previously existing crack were monitored and were found to follow changes in relative humidity closely. The cross-correlation function of the crack width and the RH was calculated, and showed that the crack width followed the RH with a time lag of approximately 41 hours. The object hardly responded at all to more rapid fluctuations.

INTRODUCTION

Although there have been many laboratory studies on dimensional changes in wood caused by changes in RH, there have been very few studies of the effects of seasonal changes on historic wooden furniture in its normal display environment. This is an important distinction, because laboratory studies typically measure the rate at which a sample reaches equilibrium after a step change in RH, whereas in the natural environment RH changes are cyclical and artefacts rarely reach equilibrium.

The effects of changes in RH on wood are well documented in the literature [1]. There is anecdotal evidence in the conservation literature of catastrophic effects of RH extremes on historic wooden furniture, but it is not known whether there is a threshold in the magnitude or rate of RH change below which damage will not occur, or whether the cumulative effect of many small changes can cause catastrophic failure. There is evidence that the environmental history of a piece of furniture can substantially affect its behaviour.

Erring on the side of caution, conservators have specified a very tight range of acceptable RH, typically $55\% \pm 5\%$, but as Thomson pointed out many years ago, this was 'based more on what can be expected of an air-conditioning plant than on what exhibits can actually stand without deterioration, which is not known in any detail' [2]. Suggestions that this standard might be relaxed [3] were treated

almost as heresy, but little evidence has appeared to support either side of the argument.

An opportunity arose to investigate how a piece of historic furniture would react to its display environment, when English Heritage purchased two tables, originally made for Chiswick House in West London [4]. The tables consist of elaborately carved and gilded wooden frames, supporting heavy inlaid marble tops. Visual examination and radiography showed that the decorative elements were made of several blocks of wood glued and nailed together before being carved. Differential movement of these blocks had led to cracks in the gesso overlaying the joints. Before the tables underwent a lengthy and expensive period of conservation, the question was asked whether the tables would be harmed by being displayed in their original location in the Gallery at Chiswick House, which has a ducted warm air heating system capable of humidifying but not dehumidifying the air. It achieves reasonable control over the temperature, but less effective control of RH, which rises above 70%, and drops below 30% in the winter months. The tables were temporarily displayed in the Gallery between November 1997 and January 1998, and it was decided to attach a displacement sensor across a crack in the back of one of the decorative swags on one of the tables, in order to monitor changes in the width of the crack. The measurement used existing holes in the wood and minimised damage to the table.

METHOD

The sensor used was a linear variable differential transformer (LVDT), which converts very small displacements into a voltage signal. The LVDT is



Figure 1. Transducer attached to rear of table

about the size and shape of a ball-point pen. The body of the sensor was held by an Ω -shaped bracket on one side of the crack, while the movable ball end bore against an L-shaped stop on the other side of the crack (Fig. 1). This arrangement allowed opening and closing of the crack, and expansion and contraction of the wood to be measured.

The LVDT was connected to a signal conditioner which supplied it with an accurately controlled AC voltage, the output voltage was rectified and amplified to produce a DC signal that was proportional to the displacement of the sensor. This signal was recorded by an ACR SR-7 datalogger. The ambient temperature and RH were recorded by an ACR SR-2 datalogger. The measuring system was calibrated using automotive feeler gauges, in the range 2 – 10/1000 inch (50.8 – 254 μ m), and gave a good linear graph. The resolution of the system (limited by the resolution of the datalogger) was 1.77 μ m. Note that the absolute width of the crack was not measured (it was about 2mm), but changes in the width.

RESULTS AND DISCUSSION

Data were collected at 30-minute intervals for the period 6 November 1997 to 29 January 1998. During this time the temperature varied between 11.3°C and 20.2°C (though it was generally between 16°C and 18°C), while the RH varied between 32% and 74%. The maximum change in the width of the crack was 96 μ m – about 0.1mm.

Looking at the data (Fig. 2), it is obvious that the changes in the crack width (ΔW) follow the changes in RH, but are slightly delayed. The effects of temperature changes are insignificant. It can also be seen that while the table responds to RH changes with a period of ten days or more, it responds hardly at all to the diurnal RH fluctuations. In effect, the table acts as a low-pass filter, removing the faster changes and responding only to the slower ones.

The length of the delay between the changes in RH and the corresponding changes in crack width can be investigated by the mathematical technique of correlation, which measures how the similarity between two periodic functions changes as the time lag between the two is changed [5]. In effect, one dataset is slid past the other until the position of best match is found. A program was written to calculate the cross-correlation function of the two datasets as the lag was increased from 0 to 5 days. This showed that the maximum correlation occurred at a lag of 41 hours (Fig. 3). The maximum is quite broad, because

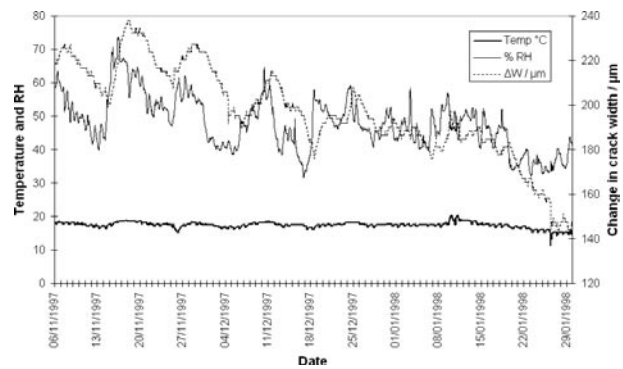

Figure 2. Crack width, relative humidity and temperature

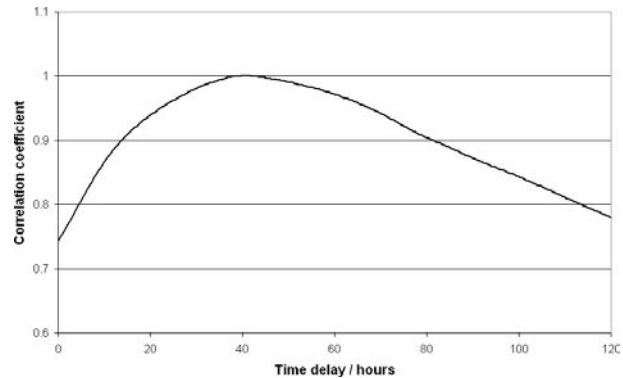

Figure 3. Cross-correlation coefficient of crack width and relative humidity

different parts of the table respond at different rates, according to their thickness, surface geometry and orientation with respect to the axis of the tree.

The implications of this are considerable. It means that any cyclic change in RH that is completed within about 41 hours is hardly felt by the table: while the surface layers do respond, the deeper layers do not respond at all to rapid changes. Only changes taking place on a longer time scale affect the deeper layers, but it is probable that the table does not reach equilibrium, even with these slower changes. The delay in the response is due to the slowness of the diffusion of water vapour into the core of the object; the gilding will also act as a partial vapour barrier.

Fig. 4 shows the crack width superimposed on the RH trace, which has been filtered by taking a 24-hour running average and shifted by 41 hours. It can be seen that there is now a very close match between the two patterns. Another example of the lack of response to rapid changes is shown in Fig. 5. On 3 January there was a rapid increase in RH, starting from 46% at midnight, reaching a maximum of 58% at 0900 and returning to 46% at 1600. The maximum response of the table would therefore be expected to have occurred 41 hours after 0900, or at approximately 0200 on 5 January. In fact, the crack width decreased steadily with no sign of an increase at this time.

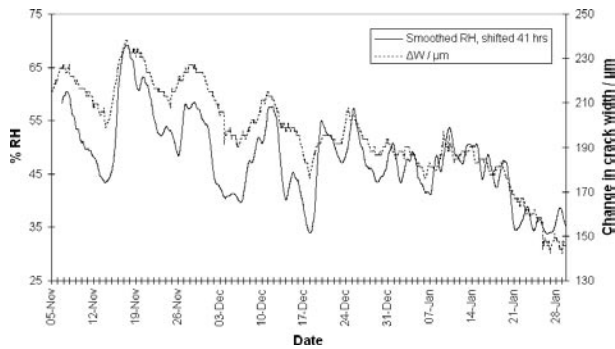

Figure 4. Crack width and smoothed, delayed relative humidity

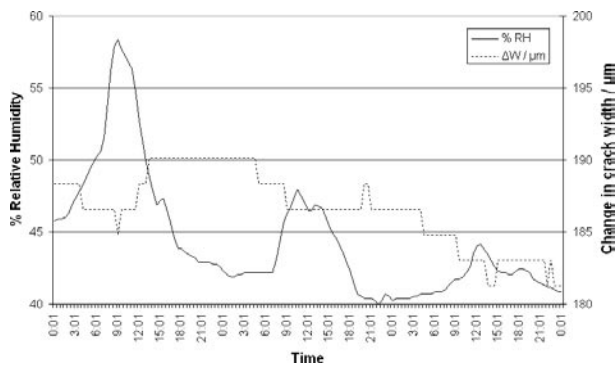

Figure 5. The crack width does not respond to rapid changes

Throughout this monitoring period, the trend of RH was downward, reflecting the normal seasonal changes, and the trend of the crack width was likewise downward. However, there is some evidence that the table releases accumulated stress by sudden jumps – a slip-and-stick mechanism. On 4 December there was a sudden decrease in crack width of $14\mu\text{m}$, followed by a small recovery, not associated with any change in RH. Similarly on 26 January there was a sudden decrease of $12\mu\text{m}$, associated with a small rise in RH and a fall in temperature – this may have been caused by opening the external doors. Changes of this size would normally be expected to result from RH changes of at least 10%, so this suggests that large changes in crack width can sometimes be caused by small perturbations.

Since this work was completed, other studies of the response of wooden artefacts to environmental changes have been undertaken, notably in connection with the “Friendly Heating” project [6]. Bratasz and Kozłowski [7, 8] describe a sensitive, non-intrusive optical system to record dimensional changes in polychrome wooden statues in a church, and relate the rates of change to stresses developed in the objects. Interestingly, they did not observe any lag between the fall in RH caused by the sudden increases in temperature when the hot air heating system was switched on, and the corresponding dimensional changes. This is probably because the optical reflector is adhered to the surface of the

object, and therefore records the rapid response of the surface, whereas in the experiment described here, the sensor is screwed to the object and therefore records the response of the object as far as the depth of the screws, about 10mm. The dimensional changes recorded are therefore smaller and more delayed. This effect was demonstrated in computer simulations by Padfield [9], in the context of the buffering of RH by wood.

AUTHORS

Barry Knight, Head of Conservation Research, The British Library, 96 Euston Road, London NW1 2DB, UK (formerly Senior Conservation Scientist, English Heritage)
Barry.knight@bl.uk

David Thickett, Senior Conservation Scientist, English Heritage, 1 Waterhouse Square, 138-142 Holborn, London EC1N 2ST, UK

SUPPLIERS

Linear displacement transducer model GTX1000, transducer indicator type E309: RDP Electronics Ltd, Grove Street, Heath Town, Wolverhampton WV10 0PY, UK

ACR dataloggers, types SR-2 and SR-7: Status Instruments, Green Lane, Tewkesbury, Glos GL20 8HE, UK

REFERENCES

- 1 Erhardt, D., Mecklenburg, M.F., Tumosa, C.S. and McCormick-Goodhart, M., ‘The determination of appropriate museum environments’, in *The Interface between Science and Conservation*, ed. S. Bradley. London: British Museum, 1997, 153-163.
- 2 Thomson, G., *The Museum Environment*. London: Butterworths, 1978, 115.
- 3 Ashley-Smith, J., Umney, N. and Ford, D., ‘Let’s be honest – realistic environmental parameters for loaned objects’ in *Preventive Conservation: Practice, Theory and Research*, ed. A. Roy and P. Smith. London: IIC, 1994, 28-31.
- 4 Drysdale, L., ‘Conservation of the Chiswick House tables’, *Collections Review* 2 (1999) 73-76.
- 5 Chatfield, C., *The Analysis of Time Series: an Introduction*. London: Chapman & Hall. 1984.

- 6 Camuffo, D., Sturaro, G., Valentino, A. and Camuffo, M., “The conservation of artworks and hot air heating systems in churches: are they compatible?”, *Studies in Conservation* 44 (1999) 209-216.
- 7 Bratasz, L. and Kozłowski, R., “Laser sensors for continuous in-situ monitoring of the dimensional response of wooden objects”, *Studies in Conservation* 50 (2005) 307-315.
- 8 Bratasz, L., Jakiela, S. and Kosłowski, R., “Allowable thresholds in dynamic changes of microclimate for wooden cultural objects: monitoring in situ and modelling”, *ICOM Committee for Conservation, 14th Triennial Meeting* (2005) 582-589.
- 9 Padfield, T. and Jensen, P., “Low energy climate control in museum stores”, *ICOM Committee for Conservation, 9th Triennial Meeting* (1990) 596-601.



This work is licensed under a Creative Commons Attribution - Noncommercial - No Derivative Works 3.0 Licence.

Session 3

Using knowledge of the effects of climate:
surveying actual collections

A HOLISTIC APPRAISAL OF ENVIRONMENTAL CONDITIONS IN THE NATIONAL ARCHIVES, UK

KOSTAS NTANOS AND NANCY BELL

ABSTRACT

The National Archives (TNA) UK, formally the Public Record Office, houses over 10 million records that span over a thousand years of English and British history. The collection currently occupies approximately 180km of shelving and is stored in two purpose built, environmentally controlled buildings at Kew, London. This facility opened in 1996 and was designed in accordance with best practice guidance at the time, as set-out in British Standard 5454. This standard recommends that environmental storage conditions be maintained at 16-19°C ±1 and 40-65% RH ±5%. Prior to the move to Kew the collection had been stored in uncontrolled environmental conditions at a site on Chancery Lane, central London, for approximately 150 years.

TNA has always taken seriously the preservation of its records. It supports a comprehensive preservation programme, which includes rigorous environmental control. However, recent mechanical problems with the air-conditioning systems, coupled with a greater appreciation of the high cost, both financial and environmental, in maintaining these mechanical systems designed to meet BS5454, prompted a comprehensive review of our current environmental control programme.

This paper will set-out the context for environmental standards maintained at TNA, it will describe the background issues prompting a holistic appraisal of TNA's current environmental provision, it will describe the findings of research projects underpinning our review, and will discuss how it is striving to translate research findings to support the environmental appraisal and to inform its future programme of stewardship.

RESEARCH PROJECTS SUPPORTING THE ENVIRONMENTAL APPRAISAL: A SUMMARY

IDAP 150: A COMPARATIVE STUDY OF TWO GROUPS OF PARCHMENT RECORDS

The conservation science section assessed two groups of parchment records stored in two contrasting

microclimates for a period of approximately 150 years. Using IDAP (Improved Damage Assessment of Parchment) protocols, this project aimed to determine if there was a difference in the deterioration of historic parchment records kept in two environments. The Conservation science assessed two groups of parchment records that had been stored in contrasting microclimates for a period of approximately 150 years. Results thus far indicate no significant difference between the two groups, although the interpretation of these findings is open until the fibre assessment is completed.

RISK ASSESSMENT MODELS

Using risk assessment models developed over the last ten years, TNA is undertaking a comprehensive evaluation of hazards to its collection. The risk assessment will help prioritise work and ensure responsible resource management.

CLIMATE MAPPING EXERCISE

A climate mapping exercise is underway in all storage areas. The results will be used to develop TNA's environmental monitoring programme as well as to improve the hardware and the Building Management System (BMS). In addition, we have experimented with the operation of the air-conditioning system and the response of the ambient storage conditions. The effects of these changes were monitored in the storage areas and inside the storage boxes. The evidence gathered from this exercise is being used to establish the thermal stability of the building, and to adjust the air-conditioning settings.

VOLATILE ORGANIC COMPOUNDS (VOCs)

To understand more about the air quality in TNA's storage areas, we are collaborating in a research project led by The British Library and in collaboration with other partners. This project will characterise and quantify volatile organic compounds present in archive collections.

COLLECTIONS CHARACTERISATION

In an effort to ensure appropriate environmental conditions for all the materials in the collection, we are systematically surveying environmentally

sensitive materials e.g. plastics and photographs, to estimate their condition in order to predict their life expectancy. This information will enable us to prioritise our work and allocate costs effectively.

INTRODUCTION

Over the last ten years, the critical environmental parameters affecting paper-based collections. Emerging risk assessment models and the potential of cost-benefit analysis protocols applied to preservation problems are just two examples of cross-disciplinary thinking that is invigorating critical appraisal of preservation policies and practices. Against this background, the Department of Collection Care in The National Archives (TNA) is taking a leading role in delivering a holistic and critical evaluation of current preventive environmental practice within the context of developments in preventive conservation advanced over the last ten years.

The National Archives is the official archive for England, Wales and the central UK government, containing 900 years of historical records from *Domesday Book* (1086) to the present, with records ranging from parchment and paper scrolls to recently created digital records and archived websites. TNA currently holds more than 10 million parchment and paper-based records that occupy 180km of shelving. Before 1978 the records were stored in central London at a site in Chancery Lane. This was a purpose built facility for court records, which in 1838 became the Public Record Office. In 1978 part of the collection was moved from Chancery Lane to Kew in a newly opened extension that provided five repositories. In 1996 a further extension opened adding a further 12 repositories. The main entrance of The National Archives links the 1978 and 1996 buildings, known to staff as Q1 and Q2 respectively. Today most of the records are kept on the Kew site with some 20% stored in Deepstore,



Figure 1. The National Archives, Kew, London UK

a salt mine in Cheshire. There were further changes in the development of the Archive. TNA is a constantly evolving organisation; The name changing from Public Record Office (PRO) to The National Archives in response to the merge of the Historic Manuscript Commission (HMC) and PRO.

THE CONTEXT: TNA'S CURRENT PROVISION FOR ENVIRONMENTAL MONITORING AND CONTROL

Until a proportion of the records were moved to Kew in 1978, the collection was kept in uncontrolled environmental conditions, so the move clearly marked a significant shift to an improved standard of care. Both buildings at Kew operate air conditioning systems, although each has different air handling and conditioning system. Each is maintained and serviced under a separate Building Management System (BMS), outsourced to a private contractor. Both systems were designed to meet the recommendations in British Standard 5454 [1] which specifies a temperature set point between 16-19°C with $\pm 1^\circ\text{C}$ fluctuation. The relative humidity set point is between 45-60% RH with $\pm 5\%$ allowable fluctuation.

The scale of operation necessary to maintain environmental standards within the recommended parameters for these two buildings is both daunting and complex. The air conditioning system servicing the repositories, public areas, and offices is controlled by eleven plant rooms in Q1 and nine in Q2. There are 22,000 litres of water in the system in Q2 alone, which is chilled to almost freezing temperatures in order effectively to condition the incoming air. In recent years the two systems have not always coped with extended periods of hot weather during the summer months, nor were they designed to do so. The two systems operate at capacity 365 days a year; this has proved both costly and sometimes ineffective.

There were a number of other factors giving rise to the holistic appraisal of environmental standards policy. First the mechanical limitations of TNA's current air conditioning system, that inevitably will worsen over time, and indeed may be exacerbated in view of the predicted warmer summers in the UK. Our data gathering exercise identified the existence of highly variable local environments in the repositories. Second, given the very few BMS sensors used to monitor the environment, the existence of local environments, not surprisingly, was unknown. Lastly, the newer of the two air conditioning systems in Q2 was already over 10

years old and as expected nearing the end of its useful life and therefore we needed to make provision for its maintenance and replacement.

While we appreciated a compelling need to upgrade TNA's environmental control system, we firmly believe future modifications should be nested in a sustainable environmental policy. TNA is committed to a 'greener' policy, and is actively engaged in developing environmentally responsible and sustainable practices. Tackling climate change is also high in the UK government's agenda, as shown by a recent announcement that all public sector buildings in the UK will soon be required to display their carbon footprint and define and agree targets to reduce carbon emissions [2]. Understanding and responding to the effects of climate change on cultural heritage is an enormous challenge being taken up in the cultural heritage sector, as demonstrated by current research underway in this area [3].

*APPRAISING CURRENT POLICY:
RECOMMENDATIONS, STANDARDS, GUIDELINES*

TNA's current environmental standards, like those of most libraries and archives in the UK, are guided by the recommendations in BS5454. The extent to which this 'gold' standard should determine practice is currently being debated in TNA. The foreword to BS5454 makes clear that the standard is a series of recommendations in the form of guidance, although BS 5454 is too often interpreted as a strict definition of storage climate. The slow process of revision also means current thinking on environmental issues and innovation is not captured quickly and consequently the standard is soon out of date. Defined and easily interpreted numerical boundaries for environmental requirements is convenient and therefore attractive to advisory panels and government inspection bodies; however, it does not address the complexity of thoughtful environmental management. Future published guidance, we believe, will place greater emphasis on a risk-based approach to collection management, and will be informed by a range of information such as the kinetics of decay and questions of environmental sustainability.

The environmental appraisal has also prompted us to re-examine the scientific evidence underpinning BS5454. Recommended values of relative humidity and temperature around the mid range were selected primarily on the basis of human comfort and mechanical feasibility, as pointed out by S. Michalski [4]. Other published guidelines [5, 6] have

recognised that a single set of recommendations for all contexts is inappropriate. The size, type, the condition of the collection, available resources, storage conditions and local climate are just some of the factors that need to be considered when developing recommendations.

*NEXT STEPS IN TNA'S REVIEW OF
ENVIRONMENTAL STANDARDS*

The Department of Collection Care is leading the critical evaluation of current preventive environmental practice in consultation with other departments such as Estates, Security, Information Technology and Financial Services. The first step in the environmental review will be to upgrade the air-conditioning system to provide seasonal drift of relative humidity and temperature set points. This change departs somewhat from the long-held view of providing constant climatic conditions and in addition may occasionally lead to levels outside those currently recommended. This accepts that environmental hazards are found in collections, but these risks can be mitigated; it also recognises that different environments are appropriate for collections with different needs. We are also learning from other institutions taking this approach that significant cost savings can be made, and the impact on the environment lessened.

*PROVIDING EVIDENCE/BUILDING A PICTURE:
COMPARATIVE STUDY OF TWO GROUPS OF PARCHMENT
RECORDS*

To accumulate the evidence necessary to understand the complex environmental problems and to inform our decisions around TNA's environmental policy, we interpret published research findings as well as supporting other research projects, independently or in collaboration with other external partners. For example, over the last year we have undertaken a comparative study of two discrete groups of parchment records. Varied storage locations through the centuries coupled with the lack of any environmental monitoring data from the National Archives prior to 1998 makes it impossible to associate the current state of preservation of our collection of parchment documents to specific factors of degradation or even further to specific environmental conditions. However, between 1830 and 1994 the collection was stored in the Chancery Lane building. Although there was no mechanical environmental control there were prevailing environmental conditions in the different floors of the building, dictated by their topography

and the building's construction. The move of the records from Chancery Lane to Kew and the development of the Improved Damage Assessment of Parchment (IDAP) [7] protocols presented a great opportunity to undertake a comparative study of the natural ageing of historic parchment documents in uncontrolled environments with that of the controlled environment of the repositories in Kew. Building on the work of the IDAP programme, we assessed two groups of parchment records stored for a period of approximately 150 years in very different microclimates. All the documents examined from the two Groups dated between 1450 and 1500 so they were already more than 350 years old when The Public Record Office was created at Chancery Lane in 1830. Our investigation aimed to determine which of the two sets of conditions had the greatest impact on the overall deterioration of the documents.

The first group of documents (Group A) examined for this study, consisting of two classes of records (C1 and JUST 3), stored on the top floor of Chancery Lane. The second group (Group B), from one class (C4) was stored in the basement. Anecdotal information suggested that the top floor was consistently hot and dry while the basement was known to be cool and damp, as it was situated over the River Fleet, which could be seen from manholes in the floor. Conservators boxing the collection prior to the move to Kew reported the obvious difference in the flexibility of the records stored in those two locations.

The documents from C1 sometimes stitched on the corner and possibly were lightly cleaned during the stitching process. In contrast, JUST 3 had been subject to extensive conservation treatment in 1959, which included humidification and subsequent pressing. A paper strip or 'guard' was also attached on the left side of each document to enable each record to be stitched together and bound in small pamphlets with covers made of bookbinding cloth. Class C4 is a collection of loose parchment documents never subject to any conservation treatment.

To determine the physical condition of the documents, 50 samples of collagen fibres were taken from individual documents from each class, and tested according to the IDAP protocol for Hydrothermal Stability Shrinkage Activity, measured using the Micro Hot Table Method (MHT). The datasets of the shrinkage temperatures of the two groups of documents were statistically checked for outliers and then compared by means of two-tailed F-test and t-test at a 95% confidence level, to determine if the mean values differed significantly (fig. 2).

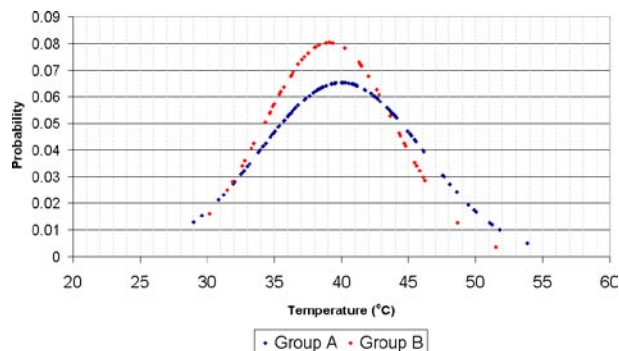

Figure 2. Distribution of shrinkage temperature for Group A and B.

The mean shrinkage temperature for the documents from Group A was 40.0°C and for Group B 39.1°C. Statistical analysis showed no significant difference between the two.

However, when the two classes in Group A were examined separately, the mean shrinkage temperature of class JUST 3 was 2.7°C higher than the one of C 1 series, both were stored on the same floor in Chancery Lane. Statistical analysis between JUST 3 and C 1 showed a significant difference between their two mean values.

There are numerous factors that can influence the shrinkage temperature of parchment, for example the animal species, the part of the skin the sample was taken, the method of production, previous storage conditions and past conservation treatments. The large number of variables expected with parchment documents is evident in the wide standard deviation calculated for all three classes. Accepting that all three classes of documents were exposed to the same environmental variability throughout their lifetime, the difference in shrinkage temperature is likely to be caused by the manufacturing process, effects of previous conservation treatments, or variables in the skin itself e.g. species type.

Interestingly, most of the documents from class C4 were deemed unsuitable for delivery to readers due to their dirty, creased and fragile condition. However, analysis showed the C4 documents were in the same state of preservation as C1. The results of this study have prompted a number of questions and therefore careful interpretation and further investigation before drawing firm conclusions. At this stage we can conclude that neither of the two extreme environmental conditions seem to have affected one group of documents more than the other. The two groups of documents have either been affected by the two contrasting environmental conditions or the environmental variability of the

last 150 years, even though conditions must have been on average more extreme, did not exceed the variability of the uncontrolled environment of the previous 350 years. Thus the 150-year period has not caused significantly more damage than what had already been caused until then.

In line with previous work focused on the response of humidity-sensitive materials to RH fluctuations, this preliminary conclusion may suggest that flat-line environmental control for collections of unbound parchment documents exposed to uncontrolled environments for most of their lifetime might not be necessary. Collections exposed to large fluctuations would be able to tolerate at least half of that fluctuation without any additional damage [8]. Therefore the benefits to the long-term preservation of the collection are minimal in comparison to the costs involved in maintaining an extremely stable environment. This view is also supported by the current risk assessment of TNA's collections.

Finally, this project will contribute to the continuous development of the IDAP assessment protocol by submitting all the experimental data to the IDAP database. It has also emphasised the need for coupling shrinkage temperature measurements with fibre assessment, in order to avoid misinterpretation of experimental results.

RISK ASSESSMENT PROJECT

Using the risk assessment model developed by Dr Robert Waller, Canada, [9] we have identified and quantified the risk to the collection due to inappropriate environmental conditions. The magnitude of risk due to conditions that fall outside the recommended values in BS5454, when viewed in relation to other risks may not necessarily indicate a priority on the preservation agenda. Environmental conditions are only one element affecting the preservation of the records and therefore must be assessed accordingly when allocating resources for the mitigation of risks to the collections. The results of the risk assessment numerically demonstrated that the risks associated with inappropriate levels of RH and T is far greater than the hazards posed by fluctuating environmental conditions.

CLIMATE MAPPING EXERCISE

Indications suggesting the existence of microclimates within the repositories prompted a data gathering exercise to be carried out in 2007. The exercise involved dividing each of the repositories into

several 1000m² areas. Forty data loggers that record T and RH were arranged in a grid within one area at a time, and left to record for 48h before being moved to the next area, until the entire floor space was covered. A static data logger in the centre of each repository was used as reference sensor and a map of the differential RH and T was constructed for each space. All data loggers were set to record at 15-minute intervals. Even with a short monitoring period, the exercise to map the whole repository floor space in both buildings was estimated to take more than three months.

Climate maps for each repository were constructed by subtracting the readings of each data logger from the readings of the data logger in the centre of the repository. The maximum difference in %RH (% Δ RH) and temperature (Δ T) that was recorded during the 2-day monitoring period of each square on the grid is graphically presented in Figure 3. Similar maps were also constructed for the average % Δ RH and Δ T, in order to distinguish between events that occurred only for a short period of time and areas in the repositories where environmental conditions were on average at different levels.

Despite the limitations of the monitoring exercise, the results conclusively showed areas on each floor with very different environmental conditions. This is in contrast to the environmental picture of the repositories created by the existing monitoring programme and BMS, which was very similar to what the data logger in the centre had recorded, and interestingly conformed with the recommendations set out in BS5454. Information from the climate maps and the data generated from individual data loggers led to a much better understanding of the necessary improvements in the monitoring programme, environmental control system and air distribution. More importantly, the evidence showed the air-conditioning system was more efficient and less affected by the external environment, human occupancy, and the furniture arrangement i.e. shelving than was first thought.

In addition, we have also investigated the effects on the stability of the storage conditions of changing the operational patterns of the air-conditioning system, as well as the microclimates inside the storage boxes. The air-conditioning was switched off and the environmental conditions were monitored inside and outside a typical storage box. The conditions inside the repository remained virtually the same even after seven hours without a supply of conditioned air. Therefore, it was not possible to fully assess

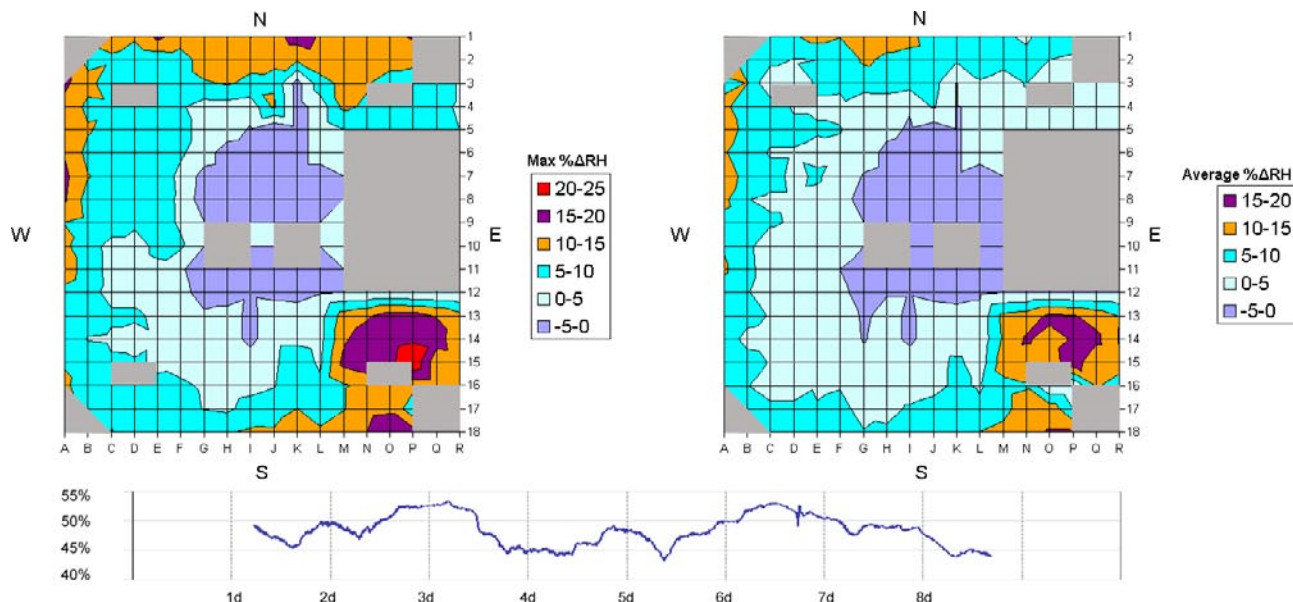

Figure 3. Climate maps of the second floor repository in Q1 (surface area 7,377 m²). The graph along the bottom shows the RH recorded at the centre of the repository over an eight-day period.

the buffering capacity of the storage boxes against fluctuation of ambient environmental conditions in situ, but we gained useful insight of the thermal and moisture stability of the building envelope. Data from further trials will inform the operation schedule of the air-conditioning system and as long as environmental conditions remain stable we might reduce operating hours of the air conditioning.

VOLATILE ORGANIC COMPOUNDS (VOCs)

Our environmental review is currently focused on temperature and relative humidity control, with a planned evaluation of internal air quality. To this end we are collaborating in a project led by the British Library to characterise the off-gassing of volatile organic compounds (VOCs) in archival collections with the view to correlating condition to the quantity and type of VOCs found. The ultimate aim of the project is to produce a diagnostic tool for the assessment of such collections. It is also envisaged that the results of this study will inform understanding of the degradation processes and the interactions of materials kept in microclimates.

The environmental review currently underway in TNA is just one element contributing to a new approach to collection stewardship. We are also actively profiling the collections to identify environmentally sensitive materials where more tightly controlled microclimates may be more appropriate. For example, a survey of the photographic collection is underway to identify the range and quantity of photographic materials found in the collection. The range of modern archival materials, such as plastics, some of which are already

showing signs of decay. The purpose of this is to provide the necessary evidence to enable an improved, informed top-down approach to stewardship.

TNA's multi-faceted approach to collections stewardship is not unique, although rare on the scale presented here in TNA. It is envisaged that we will continue to collect comprehensive evidence in the ways set out in this paper to enable stewardship policies and practices to be revised accordingly.

AUTHORS

Kostas Ntanos
Collection Care Department
The National Archives
Ruskin Avenue
Kew, Richmond, Surrey TW9 4DU, UK
kostas.ntanos@nationalarchives.gov.uk

Nancy Bell
Research & Collections
The National Archives
Ruskin Avenue
Kew, Richmond, Surrey TW9 4DU, UK

REFERENCES

- 1 British Standard Institution (2000) *BS Recommendations for the storage and exhibition of archival documents*. BS 5454:2000, BSI, London.

- 2 'Fridge Ratings For Museums' – Government Announces Plans For New Energy Ratings For Public Buildings, Communities and Local Government News Release 2007/0065, 29th March 2007
- 3 <http://noahsark.isac.cnr.it>
- 4 Michalski, S. (1993) *Relative Humidity: A Discussion of Correct/Incorrect Values*, ICOM Committee for Conservation 10th Triennial Meeting, Washington, DC, 22-27 August 1993: Vol.II (Ed, Bridgland, J.), International Council of Museums Committee for Conservation, Paris, pp. 624-629
- 5 Museum, Libraries and Archives (2003) In *ASHRAE Handbook HVAC Applications*. Atlanta: American Society of Heating, Refrigeration and Air-Conditioning Engineers, Chapter 21
- 6 Michalski, S. (2000) *Guidelines for Humidity and Temperature for Canadian Archives*, Technical Bulletin No.23, Canadian Conservation Institute, Ottawa, Canada
- 7 Larsen, R. (2002) *Microanalysis of Parchment*, Archetype Publications, London, UK
- 8 Ibid. [4]
- 9 Waller, R. (2002) "A risk model for collection preservation" ICOM Committee for Conservation, ICOM-CC : 13th Triennial Meeting, Rio de Janeiro, 22-27 September 2002, James & James, London, United Kingdom, vol. 1, p. 102-107



This work is licensed under a Creative Commons Attribution - Noncommercial - No Derivative Works 3.0 Licence.

INVESTIGATION INTO IMPACTS OF LARGE NUMBERS OF VISITORS ON THE COLLECTION ENVIRONMENT AT OUR LORD IN THE ATTIC

SHIN MAEKAWA, BART ANKERSMIT, EDGAR NEUHAUS, HENK SCHELLEN, VINCENT BELTRAN
AND FOEKJE BOERSMA

ABSTRACT

Our Lord in the Attic is a historic house museum located in the historic center of Amsterdam, The Netherlands. It is a typical 17th century Dutch canal house, with a hidden Church in the attic. The Church was used regularly until 1887 when the house became a museum. The annual total number of visitors has grown from 36,000 in 1990 to 75,000 in 2005; this trend is exponentially increasing. The museum had between 100 – 650 visitors each day in 2005; they typically stayed in the building for about an hour. There were two visitation peaks: one in the mid-morning and another in mid-afternoon. On two separate days each year the museum records large numbers (well over 1,000) of visitors. Masses, weddings, and music concerts, attended by 50 – 150 persons, are regularly held in the Church. The museum has consequently expressed major concern over the impact of the growing number of visitors on the various collection environments.

A historic indoor climate of 10% - 95% relative humidity was estimated, from when the central heating system, which may have caused the majority of damages to the collection, was installed in the 1950's to the installation of humidifiers in the 1990's. However, between January 2005 and January 2006, in spite of a few central heating system malfunctions and large visitor numbers that particular year, the recent climate in the museum building did not reach harmful levels for the collections.

Direct impacts of visitors were documented as increases in temperature, relative humidity, and CO₂ concentration when the museum opened each morning as well as during special events in the church. However, relative humidity peaks remained less than 75%, and the value decayed quickly after the visitors had left the rooms or near the end of the museum's visiting hours. As confirmed through air exchange rate measurements in the church, a high infiltration rate of outside air was the reason

for reduced peaks and fast decay of the relative humidity and CO₂ concentration.

Daily maxima of CO₂ concentration exceeding 1500 ppm were recorded whenever the daily total of visitors exceeded 500. Daily averages over the 08:00 – 17:00 period exceeded 1000 ppm whenever more than 600 visitors were recorded. However, the high infiltration rate completely diluted the CO₂ concentration to an ambient level by the following morning.

From the consideration of the CO₂ and moisture accumulations, 600 visitors per day, well-distributed over the museum's operational hours, can be safely accommodated in winter. The number can be increased to twice this during the summer by opening the entrance door and a window in the attic for increased natural ventilation. However, other important issues, such as safe levels of floor loading and vibration, as well as overall visitor comfort and experience, will have to be taken into consideration and may well result in allowing fewer visitors than what is recommended based on these calculations.

INTRODUCTION

Our Lord in the Attic ('Ons' Lieve Heer op Solder') is a historic house museum located in the red light District of Amsterdam, The Netherlands. It is a typical 17th century tall Dutch canal house with brick walls and large windows. The building has an approximate footprint of 260 m² with five floors and an estimated volume of 2500 m³. After Jan Hartman, a German Catholic and successful merchant, purchased the building in 1661, he created a hidden Catholic church in the attic, since the open practice of Catholic Mass was officially forbidden at that time in the Dutch Republic. The church was used until 1887 when the house became a museum. Since the 1950s, the church has been used periodically for religious ceremonies and special events.

The museum (see Figure 1) consists of several historic rooms: Canal Room, Sael, Kitchens (not indicated in

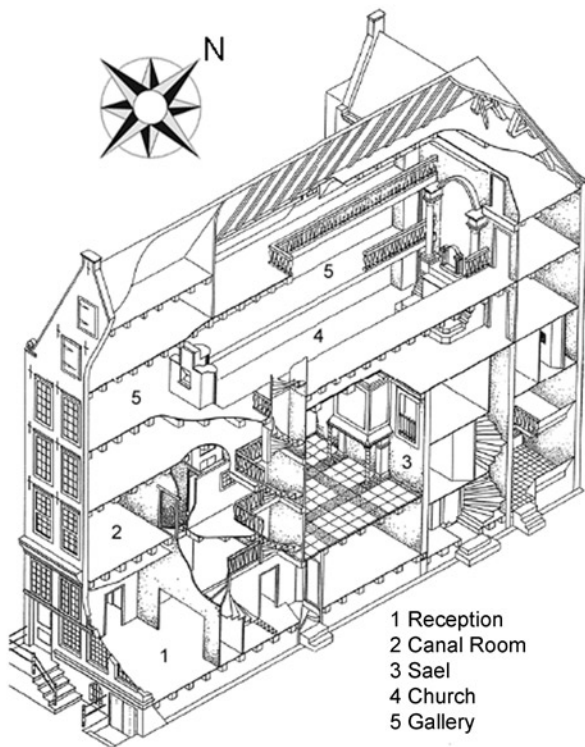

Figure 1. A schematic view of the museum *Our Lord in the Attic*

the figure), and Church. The church is located in the middle of the building and extends from the 3rd to the 5th floor and through partially removed floors on the 4th and 5th floors. The southwest wall is mostly shared with the next building; the northeast wall faces an alley. The church has a floor area of 150 m² and a height of 9 m (volume of 1350 m³). The brick walls are plastered, and the floor and galleries are constructed from wood. The painted wooden ceiling has a 0.55 m diameter opening leading to the attic above. There are several accesses to the Church, and the galleries are connected by steep and narrow stairways.

The museum's collection consists of approximately 7,000 objects of various materials dating from the 16th century to the present day. In fact, the building itself is seen as an important part of the collection. As is common in a historic house museum, most objects, such as furniture, paintings and wooden sculptures, are on open display. Some metal objects are exhibited in showcases for security. The objects currently on display in the museum came to the building at different times. The first religious objects were brought to the building shortly after it became a church. When the church operated as a museum, objects from other hidden churches in the area which were being closed were added to the collection.

In the 1950s, the museum installed a central heating system to provide comfort for both visitors and staff members. In the early 1990s, portable humidifiers and dehumidifiers were placed at various locations in

an attempt to control seasonal variations of relative humidity for an improved collection environment. There is no air-conditioning system, and visitors have often complained of the uncomfortable climate during hot and humid days in summer. Recently, freestanding oscillating fans were placed throughout the museum to provide some relief during the summer.

The number of museum visitors has been steadily growing. The annual total number of visitors grew from 36,000 in 1990 to 75,000 in 2005, and this trend is exponentially increasing. The museum has consequently expressed major concern over the impact of the growing number of visitors on the collection environments for both objects and the building's historic interior. Therefore, the present study was conducted, combining an environmental assessment with a condition survey, to identify the impact of visitors on the collection, building, interiors and the environment in order to develop an environmental management strategy that balances presentation, access and preservation.

First, the historic indoor climates in the museum were estimated, based on available historic outdoor climate data of the area, thermal characteristics of similar Dutch historic buildings, and recorded historic heating methods in the building. Then, the current indoor climate in the building was examined. And last, the impact of special events involving large groups in the building was analyzed. The effect of visitors on the indoor climate was analyzed and an attempt was made to estimate the maximum number of visitors that would limit environment change to acceptable levels.

HISTORIC CLIMATE

The historic indoor climate was estimated using 20th century outdoor climate data of nearby cities (KNMI website) and available indoor climate data of other historic buildings in The Netherlands. The outside air was assumed to infiltrate into the building and be heated by the building, resulting in a lower indoor relative humidity.

Light buildings, such as a typical canal house, remain warmer than the outside throughout the year. However, in winter, these buildings were often heated to provide additional thermal comfort for occupants. Heating methods applied in *Our Lord in the Attic* over the years were recorded as follows:

1661 - 1953: Local heating by fireplaces and wood or coal stoves in individual rooms but no heating in the Church.

1953 - Present: A centrally located boiler provides heated water to radiators throughout the building, except the Canal Room and Reception, which have gas fired stoves. The thermostat is currently set at 20°C in winter.

In 1990, twelve portable cold-evaporative type humidifiers (capable of 0.9 litres per hour) and two refrigerant-based dehumidifiers (capable of 0.25 litres per hour) were introduced into the building to improve the relative humidity for collection preservation. These devices have been set to maintain 50% RH.

LOCAL HEATING (TILL 1953)

The environmental monitoring conducted in other unheated buildings in The Netherlands showed that indoor temperatures never dropped below 17.5 °C during summer and 8 °C in winter. In wintertime, local heaters such as fireplaces and stoves were used to provide thermal comfort. However, the church did not have a heater until 1953. During mass, people would use small portable stoves with glowing peat.

The unheated church would have had the temperature of typical unheated buildings, with only some heat drifting from other parts of the house. However, the overall contribution of the local heating in the Canal Room and the Sael to the temperature in the Church is assumed to have been relatively small. The following assumptions are made:

Objects displayed during this period were exposed to indoor temperatures ranging from 8°C to about 25°C. The relative humidity in the church was slightly different from the heated rooms and would have varied annually between 15% and 90%, while in the heated Seal and Canal Room the relative

	T_{outside}	T_{Church}	$T_{\text{Canal Room}}$ and T_{Sael}
Winter	<-5°C		Heated to 8 °C
	-5°C < and < 0°C		Heated by 10 °C
	0°C < and < 5°C		Heated by 7.5 °C
	5°C < and < 10°C		Heated by 5 °C
	>10°C		Same as T_{outside}
	< 8°C	Heated 8 °C	
	8°C < or < 10°C	Heated by 0.5 °C	
	>10°C	Same as T_{outside}	
Summer	< 17.5°C	Heated to 17.5 °C	Heated to 17.5 °C
	> 17.5°C	Same as T_{outside}	Same as T_{outside}

Table 1. Estimated temperatures in Canal Room and Sael (heated) and Church (unheated) till 1953

humidity would have varied annually between 10% and 90%. However, these ranges include short excursions. When the short-term variations were excluded, the relative humidity ranges reduced to 30-70% for the unheated space and 25-70% for locally heated spaces.

CENTRAL HEATING (1953-1990)

After the central heating system was installed in 1953, winter indoor temperatures became warmer and stable. Unfortunately, we were unable to find set temperatures of the heating system during that period; therefore it was assumed that indoor temperatures were kept at 17°C during the day and 13°C at night. In summer, indoor temperatures remained similar to those observed in 2005 and 2006, never below 17.5°C. These temperatures produced wide relative humidity ranges, between 10% and 95% in winter and 30% to 95% in summer.

CENTRAL HEATING WITH HUMIDIFIERS AND DEHUMIDIFIERS (1990-PRESENT)

After humidification and dehumidification were introduced to the building, control of relative humidity became possible. Since January 2005, climate data have been collected throughout the building. Temperature and relative humidity have been continuously recorded in various rooms and outside. The concentration of carbon dioxide was also recorded in the church for a limited period in 2006. In addition, the air exchange rate of the church was measured in both winter and summer. The museum staff also recorded daily totals of visitors and total amounts of water both supplied to humidifiers and collected from dehumidifiers.

MONITORING RESULTS (2005-2006)

Although all windows of the museum are always closed for the security reason, they allow direct sunlight onto the collection. The windows near the altar and the Lady Chapel have roller blinds, which are opened by museum staff when appropriate. It is expected that both floor and ceiling allow some air leakage through floor planks.

Table 2 lists annual extremes, means and daily variations of temperature and relative humidity in the Church. During summer, the relative humidity in the Church remained mainly between 50% and 65% with most daily fluctuations approximately 5%. However, day-to-day fluctuations were approximately 7% with peaks up to 18%. Relative humidity started to drop in early November to 40-50% by the end of

Variable	Temperature (°C)	Relative Humidity (%)
Mean	20.7	52
Maximum	28.1 (24 June 15:00-21:00)	72 (28 July 15:00)
Minimum	12.9 (01 March 08:00-08:30)	34 (28 Feb. 09:00-10:00)
Daily Variation		
Mean	1.5	5
Maximum	5.3	16
Minimum	0.3	1

Table 2. Annual and daily extremes and daily variations of temperature and relative humidity in the Church (January 2005 – January 2006)

the month, remaining at that level throughout the winter in spite of the fact that humidifiers were set to maintain 50% RH.

Winter fluctuations of the temperature were small (typically 1°C as can be seen from Figure 2) due to a thermostatically controlled heating system. It should be noted, however, that in winter, large outliers were seen only at the low extreme. These were attributed to the malfunction of the heating system. The generally tight relative humidity range during winter was the result of the operation of humidifiers in the building. However, the controlled winter condition can be easily lost if the heating system malfunctions.

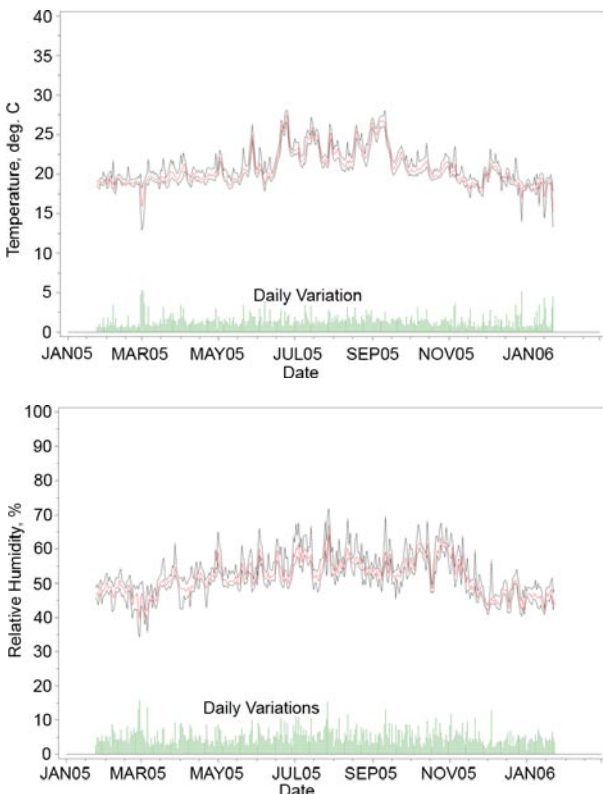

Figure 2. Plots of daily maximum, minimum, average, and variation of temperature and relative humidity in the church between January 2005 and January 2006

Although significantly high relative humidity was not recorded in the building on days with large visitor numbers and events, condensation was observed on window panes in the Church and the main staircase, which resulted in rotting of window members lattice. However, inspections with a high resolution IR camera showed that condensation was limited to the windows and not on building walls. An inspection of beam heads which are submerged into external walls of the building found five with a rotting problem. However, it was determined that this was caused by water infiltration from the outside through a deteriorated external stucco finish.

AIR EXCHANGE RATE

In an attempt to understand the natural ventilation for diluting visitor-generated heat, moisture, and carbon dioxide, the air exchange rate in the church was measured. This was done in three conditions over two days by first injecting SF6 tracer gas and then measuring rates of its dilution. The first measurement was performed on a cold spring day with all windows and the entrance door closed. An air exchange rate of 2.3 h⁻¹ was determined. The second and third measurements were performed on a warm autumn day. The second measurement, again with all windows and doors remained closed, produced the rate of 4.5 h⁻¹. During the final measurement, one window located high in the church and the entrance door at the reception were left open, producing the highest rate of 5.9 h⁻¹. Wind conditions during the measurements were similar on both days.

The rate nearly doubled in summer, and tripled by the combined effects of fresh air supply through the entrance opening and exhaust through the window high up in the church. These results proved that high ventilation rates in the church were the reason for the relatively fast dissipation of visitors' impact on the environment, as well as for partial loss of winter humidification.

VISITOR NUMBERS AND CO₂ CONCENTRATION

Daily visitor totals averaged 233 per day, ranging between less than 100 to more than 650 per day in 2005. Visitor numbers were generally distributed evenly throughout the year. However, the museum experienced higher visitor numbers between April and June in 2006 than over the same sampling period in 2005. Two daily peaks, one in the morning, between 10:00 and 11:00, and another between 14:00 and 15:00 in the afternoon, were also identified.

In Figure 3, the CO₂ concentration in the Church air was plotted for the period between March 13 and June 2, 2006, with the daily total of visitors. The majority of daily maximum values were less than 1500 ppm, and daily averages were less than 1000 ppm, which is considered a safe level for long-term exposure (ASHRAE, 2002). Daily maximum values were normally recorded during the afternoon and exceeded 1000 ppm. Larger daily totals of visitor numbers corresponded to both high daily maxima of CO₂ as well as higher averages over the 08:00 – 17:00 period. Daily maxima exceeding 1500 ppm were recorded whenever the daily visitor total exceeded 500. Daily averages exceeded 1000 ppm whenever more than 600 visitors were recorded. The infiltration of a large volume of outside air completely diluted the CO₂ concentration to the ambient level by the following morning, as there was no sign of daily CO₂ accumulation.

The average occupation in the church was less than 10 visitors, with a high extreme of 40 visitors at one time. The Church has 86 seats and is used for masses, concerts and other special events. On occasion there have been over 100 people in the Church, although the museum staff tries to observe the restricted number of 86 set by the local fire department. During some of these events, especially in summer, visitors have been complaining of uncomfortable conditions, hot and humid with no fresh air, in the Church.

EXAMPLE OF A LARGE NUMBER OF VISITORS

Exceptionally large numbers of visitors have been recorded on the annually scheduled Open Monument Days. In 2005, 1,064 visitors were recorded over a four-hour period, between 13:00 and 17:00. 24-hour variations of the temperature and relative humidity in the Church and the outside on that day were plotted in Figure 4. Temperature

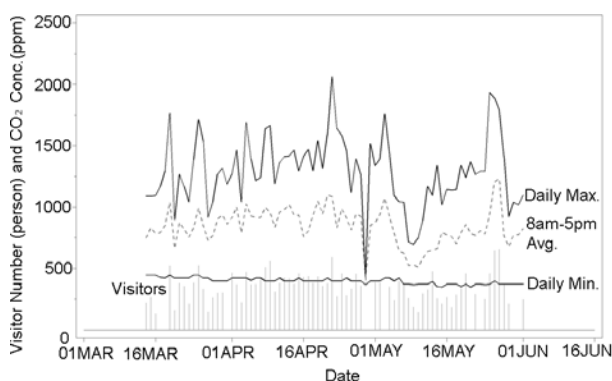

Figure 3. Daily visitation and maximum, minimum, and average CO₂ concentration in the Church of Our Lord in the Attic Museum between March 13 and June 1, 2006

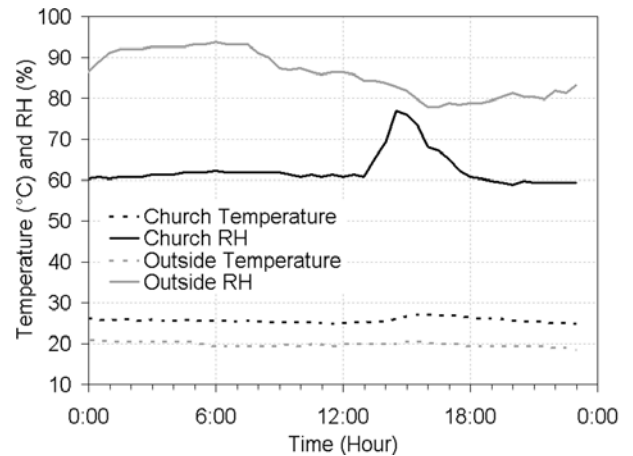

Figure 4. 24-hour variations of temperature and relative humidity in the church and outside on September 9, 2005 (Open-Monument Day).

increases were observed starting at 13:00 in all parts of the building, except in the reception, with the largest increase (approximately 2.5°C) in the church and the smallest (0.5°C) in the Sael. The exception's temperature drop during this period was probably due to the front door being opened continuously and cooler outside air entering the room. Temperatures in the building returned to normal before midnight.

Both the relative humidity and the humidity ratio increased significantly over the four-hour period in all rooms, including the Reception. However, relative humidity values throughout the building returned to normal by 21:00. The humidity ratios in both the Canal Room and the Sael peaked around 14:30, decreased for half an hour, then started to increase again, producing the second peak at 16:30 before again decreasing towards the end of visiting hours (17:00). However, throughout the day only one peak of the humidity ratio in the Church was recorded. This indicated that visitors stayed in both the Canal Room and the Sael for relatively short periods immediately after they had entered the museum. Therefore, humidity ratios in these rooms were directly affected by the rate of museum admission. However, visitors remained longer in the church, probably up to 30 minutes. The highest occupancy in the church must have been reached at 14:30, then, it gradually reduced toward closing time. The humidity ratio of the building returned to normal by midnight.

SPRING WEDDING IN THE CHURCH

As usual, Our Lord in the Attic opened its door to the public at 9:00 on May 21st, 2005, but it temporarily closed at 13:00 to accommodate a wedding in the church, which began around 14:30 and ended at 15:30. According to records kept by the museum

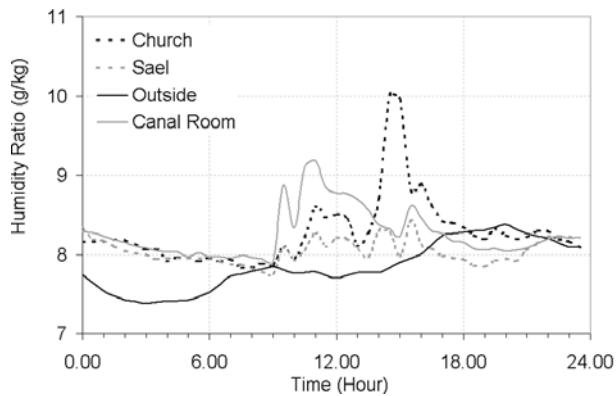

Figure 5. 24-hour variations of the humidity ratio in Our Lord in the Attic and in the outside air on May 21, 2005. A wedding with 100 attendees was held in the Church between 13:00 and 15:30.

staff, a total of 110 persons gathered for the event. The public was then allowed back in the building shortly after 15:30, after all the wedding attendees had left the building. The museum closed at 17:00 as usual.

24-hour variations of humidity ratios in Our Lord in the Attic and the outside air on that day were plotted in Figure 5. Between midnight and 09:00, the humidity ratio was constant at 8 g/kg throughout the building. A morning peak of visitors was reached between 10:00 and 11:00, exiting by 13:00. When the wedding attendees started to enter the church soon after 13:00, the church's humidity ratio had returned to 8 g/kg, the same as the outside. The humidity ratio in the church exponentially increased as wedding participants started to gather; however, the rate soon reduced to linear, and then plateaued at 10 g/kg by 15:30, indicating that the attendees had started to leave. The high rate of humidity ratio increase was due to the continuous increase of attendees in the Church over a short period. Once the ceremony had started (all attendees seated and reduced physical activities), the rate reduced due to infiltration of dry outside air.

While the church air had a significant increase in humidity ratio, both the Canal Room and the Sael were only slightly affected. Museum visitors gradually exited the museum around 17:00 and the elevated humidity ratios of all spaces dissipated towards that of the outside. All spaces equilibrated at 8.2 g/kg by 22:00.

During the wedding, the temperature and relative humidity increased from 20.9°C to 22.6°C and 54% to 60%, respectively. Relative humidity returned to 54%, a normal value without visitors, within two hours after the event. These peak values were within the limit considered to be "safe" for both objects

and the building interior. And, neither the objects nor the building interior in the Church had time to respond to the change.

ESTIMATED SAFE OCCUPANCY RATE IN ROOMS BASED ON CO₂ CONCENTRATION

If 100 persons are in the Our Lord in the Attic Museum at any given time, fresh air has to be provided at a rate of 7.5 l s⁻¹ per person to maintain a CO₂ concentration of less than 1000 ppm (ASHRAE, 2002). This rate would also control any moisture build-up. This would give the required ventilation rate of 2700 m³ h⁻¹ for the building. We estimated that the building has air exchange rates of 1-1.5 h⁻¹ in the winter and 2 - 3 h⁻¹ in the summer when the entrance door and an attic window are left open. The infiltration rates roughly yield the necessary fresh air for the winter condition. If each visitor remained in the building for less than one hour, 600 visitors can be admitted to the museum over seven hours of operation. These results further indicate that in winter, a well-distributed admission of 600 visitors during the museum's daily operating hours is the maximum at which the building would be able to provide a suitably comfortable visitor environment. However, during the summer, nearly twice the number can be admitted while a safe CO₂ concentration limit is maintained in the building.

CONCLUSIONS AND RECOMMENDATIONS

Estimated historic climates in Our Lord in the Attic revealed potentially damaging relative humidity variations (ASHRAE, 2005), especially during 1953-1990 when the central heating system was operated without control of relative humidity. The data recorded between January 2005 and January 2006 did not indicate any critical conditions in which either the collections or building interiors would be subjected to high rates of deterioration. However, our monitoring documented condensation on window panes during high occupancy events in autumn, winter, and spring, possibly causing wood rot problems for window frames and sills. These events have not caused either condensation on walls or the rotting of beam heads. The museum may consider turning off humidifiers and possibly activating dehumidifiers during such events to avoid or reduce condensation. Furthermore, lowering the relative humidity set point from the current 50% to 40% may reduce the possibility of condensation on high visitor days in heating seasons.

Both the building and the church were found to have high infiltration rates that limited heat and moisture accumulation and quickly dissipated visitors' impact on the indoor environment. This was also the reason for humidifiers not being able to maintain the set 50% relative humidity in winter. The results indicated the building's ability to handle more visitors with just open-door and window ventilation. However, this may result in an increased deposition rate of particulate matter.

From the carbon dioxide and moisture build-up consideration, the analysis indicated that the maximum number of well-distributed visitors can be nearly 600 per day in winter. It can be increased to twice the current maximum daily visitor number during the summer, especially when opening the entrance door and a window in the attic for increased natural ventilation. However, other important issues, such as safe levels of floor loading and vibration, as well as overall visitor comfort and experience, will have to be taken into consideration and may well result in allowing fewer visitors than is recommended based on these calculations.

ACKNOWLEDGEMENTS:

Authors acknowledge staff members of the Museum Our Lord in the Attic for their collaboration and support throughout the project.

AUTHORS

Shin Maekawa, Vincent Beltran, Foekje Boersma.
The Getty Conservation Institute,
1200 Getty Center Dr. Suite 700, Los Angeles, CA
90049-1684 U. S. A.
smaekawa@getty.edu

Bart Ankersmit,
The Netherlands Institute of Cultural Heritage,
Gabiël Metsustraat 8, Amsterdam, The
Netherlands

Edgar Neuhaus, Henk Schellen.
Eindhoven University of Technology,
Den Dolech 2, 5612 AZ Eindhoven, The
Netherlands

REFERENCES:

1 KNMI website, The Dutch Meteorological
Institute, <http://www.knmi.nl/klimatologie/>

- 2 Neuhaus, E. and H.L. Schellen, "MUSEUM Our Lord in the Attic in Amsterdam, Report on the indoor climate (in Dutch)" Eindhoven University of Technology, (March 2006)
- 3 American Society of Heating, Refrigeration and Air Conditioning Engineers, "ANSI/ASHRAE STANDARD 62-2001 VENTILATION FOR ACCEPTABLE INDOOR AIR QUALITY" ASHRAE (January 2002), Atlanta
- 4 American Society of Heating, Refrigeration and Air Conditioning Engineers (ASHRAE 2005) 2003 ASHRAE Handbook – HVAC Applications, Atlanta: Chapter 21



This work is licensed under a Creative Commons Attribution - Noncommercial - No Derivative Works 3.0 Licence.

WHAT'S CAUSING THE DAMAGE! THE USE OF A COMBINED SOLUTION-BASED RISK ASSESSMENT AND CONDITION AUDIT

CLAIRE FRY, AMBER XAVIER-ROWE, FRANCES HALAHAN AND JENNIFER DINSMORE

ABSTRACT

The English Heritage Collections Conservation team cares for a mixed collection distributed among 136 sites. The theory of combining a risk assessment and a condition audit was developed into a practical methodology to guide the collection care needs for such a collection. The audit is proving to be a key tool in increasing our knowledge of the risks to our collections and providing prioritised solutions and costs to reduce these risks. In addition, data from the audit is essential for influencing management and guiding research.

INTRODUCTION

Imagine that you have 136 historic sites spread across a country, housing collections of various types and sizes ranging from 10 to 10,000 objects. How do you prioritise limited resources to care for such a varied and dispersed collection?

The decision was taken by the Collections Conservation team at English Heritage (EH) to design a database and methodology integrating a risk assessment and condition survey, based on research undertaken by Taylor [1]. Crucially, it would also specify solutions and costs for the identified damage and risks, providing a means for quantifying the actions required to reduce current and future deterioration of the collections.

This paper describes progress on the development of the EH Risk Assessment and Condition Audit originally outlined by Taylor [1]. It focuses on the methodology behind the audit and the refinements made during the completion of over 100 site surveys to produce results that work in the EH context. This has ensured that the database becomes a useful long-term tool for securing and directing resources at collections at greatest risk of damage.

BACKGROUND

EH Collections are displayed in largely uncontrolled environments, mostly on open display and in many cases in their original context. For historic houses it is rarely an option to move collections to more suitable

conditions as the display philosophy is based on the exhibition of the objects in their original setting. The building can also be regarded as an 'object' in itself, often with significant architecture and interiors, limiting environmental control options. EH sites also include small, often un-manned, museums that depend on display cases to provide security and protection against the environment.

Finding the balance between conservation and display is a major challenge for heritage organisations with dispersed collections. We need to know which risks are actively affecting the collections and the solutions required to prevent this damage. We also need a way of objectively prioritising actions and resources at property, regional and national levels. The development of a solutions based risk assessment and condition audit is seen as a key tool for achieving this goal.

1995 SAMPLED CONDITION AUDIT

In 1995 EH completed a sampled condition survey of collections at 134 sites based on the methodology developed by Suzanne Keene [2]. This was a major undertaking and took four years and considerable expense to complete. It was instigated in response to a 1988 National Audit Office report, 'Management of the Collections of the English National Museums and Galleries', which raised questions about the condition of the nation's collections [3].

This early large scale condition survey of EH collections produced useful information, including the number of sites with collections (for the first time), an estimate on the total number of objects, a breakdown of the collection by category and a percentage of collections in poor and unacceptable condition. Beyond providing useful high level management data for raising the profile of the collections and arguments for additional resources, it could not verify or predict which risks may be causing damage to collections. It was the intention to survey the condition of the EH collection every ten years in order to measure progress. Unfortunately, outdated software and methodology required that a new approach was needed when the audit was to be repeated.

Progress in the application of risk assessment to the conservation field by Waller [3], Ashley Smith [4], Michalski [5] and Taylor [1] meant that the EH team could develop a new audit that combined both a sampled condition survey and a solution based risk assessment.

TURNING THEORY INTO PRACTISE

The EH Risk Assessment and Condition Audit was developed in collaboration with a researcher (Joel Taylor), practising preventive and objects conservators (Halahan Associates: Frances Halahan, Jennifer Dinsmore and Sophie Budden) and a database designer (St Albans Computer Services).

Using external consultants was the only practical way the audit could be carried out, given the size of the task. However, as the process itself is an extremely useful way to increase understanding of a site and its collection, it was essential that a member of the EH Collections Conservation team would accompany the consultants on all audits. In practice this works well as the team gains an increased comprehension of what is happening at a particular site and having someone from outside the organisation brings in fresh ideas for solutions. Additionally, external consultants balance the concerns of time and budget constraints which sometimes influenced the EH members of staff. When new members of the Collections Conservation team have joined the audit they are fully trained to maintain consistency.

For ease of use it was decided to combine the risk assessment and condition audit within a single software package. St Albans Computer Services was involved from an early stage to design a system

based on Microsoft Access™. At the time, Microsoft Access™ was mandated by the EH IT Department for the development of small databases. The database is a single computer program, available on an EH shared drive, but with 'slave' laptops, which are used on site, to import data. Drop down menus remind the auditor of the choices and keeps descriptions to a standardised set of pre-agreed terms.

There were discussions about linking the risk assessment and condition audit database with the EH collections inventory database. However, this would have delayed the risk assessment and condition audit as the collections inventory database was not completed when the audit started.

The pilot consisted of carrying out the audit at two sites. However, with hindsight, a longer pilot may have been helpful, as a number of issues which were later highlighted required changes to the database.

METHODOLOGY

The audit involves four phases, viewing locations within a site and counting objects, selecting the sample, conducting the condition survey and carrying out the risk assessment.

LOCATION AND COUNTING

On arrival at a site, the auditors view all areas where collections are displayed and stored. At a site where objects are housed in different locations with substantially different conditions and management systems, for example a basement store and public showrooms, a separate audit is carried out for each location.

Causes of damage	Examples
Dust, dirt and handling	Dust on an object due to insufficient conservation housekeeping; physical damage due to inappropriate handling, such as chips, scratches or losses.
Light	Fading of dyes and paints, yellowing of supports, embrittlement.
Incorrect Humidity	Cracks, splits, distortion due to low and fluctuating RH; corrosion, mould growth due to high RH
Pests	Damage and soiling due to insect pests, birds, rodents and bats.
Display/Storage conditions	Tarnishing of silver due to inappropriate display case materials; crushing due to overcrowding in storage; Abrasion caused by an inappropriate support.
Documentation	Incomplete or missing documentation, no identifying number marked on an object. A lack of documentation for some objects, e.g. archaeology or natural history specimens, can mean a loss of research value. This can be both symptomatic of poor collection care and may result in further neglect.
Disasters	Fire, flood, theft or vandalism.
Inherent Deterioration	Some materials deteriorate due largely to their composition rather than the conditions in which they are kept. Examples include photographs and plastic.

Table 1. Causes of damage/ risk factors

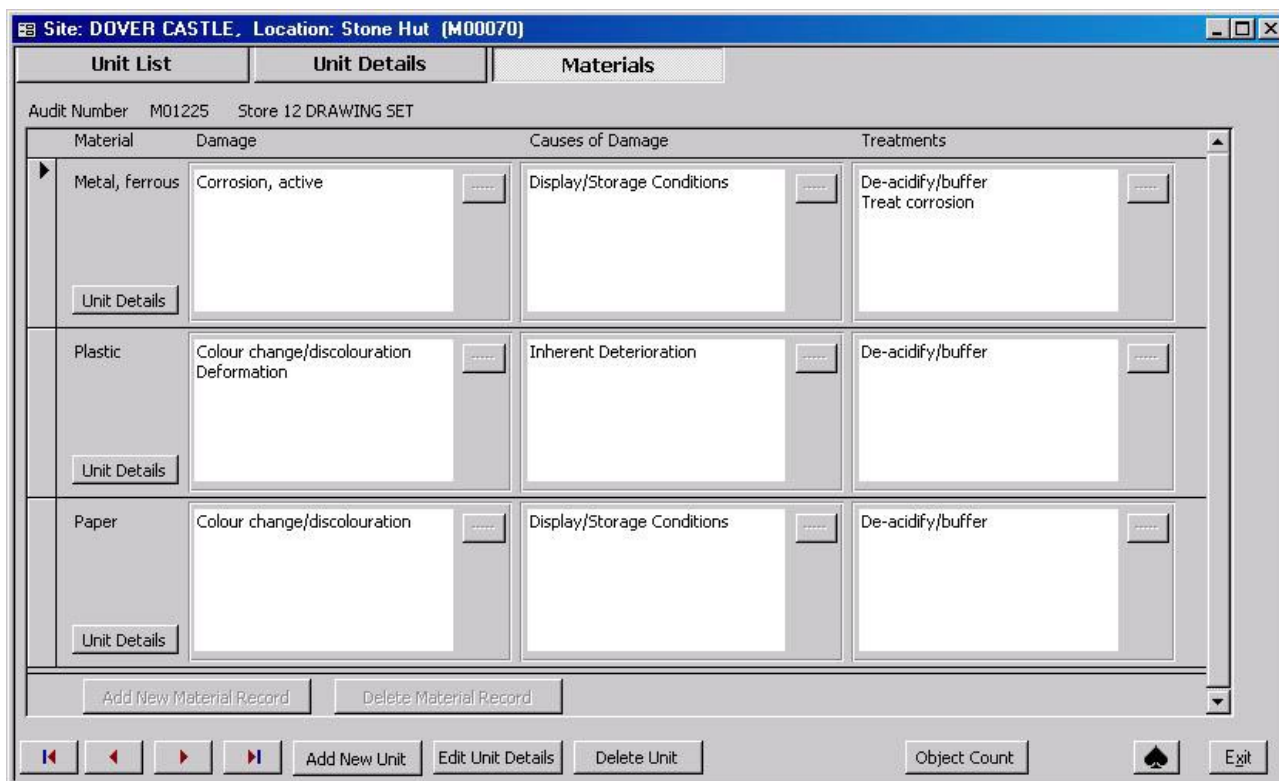

Figure 1. Screen from the audit software showing the damage to the different materials, causes of damage and treatments.

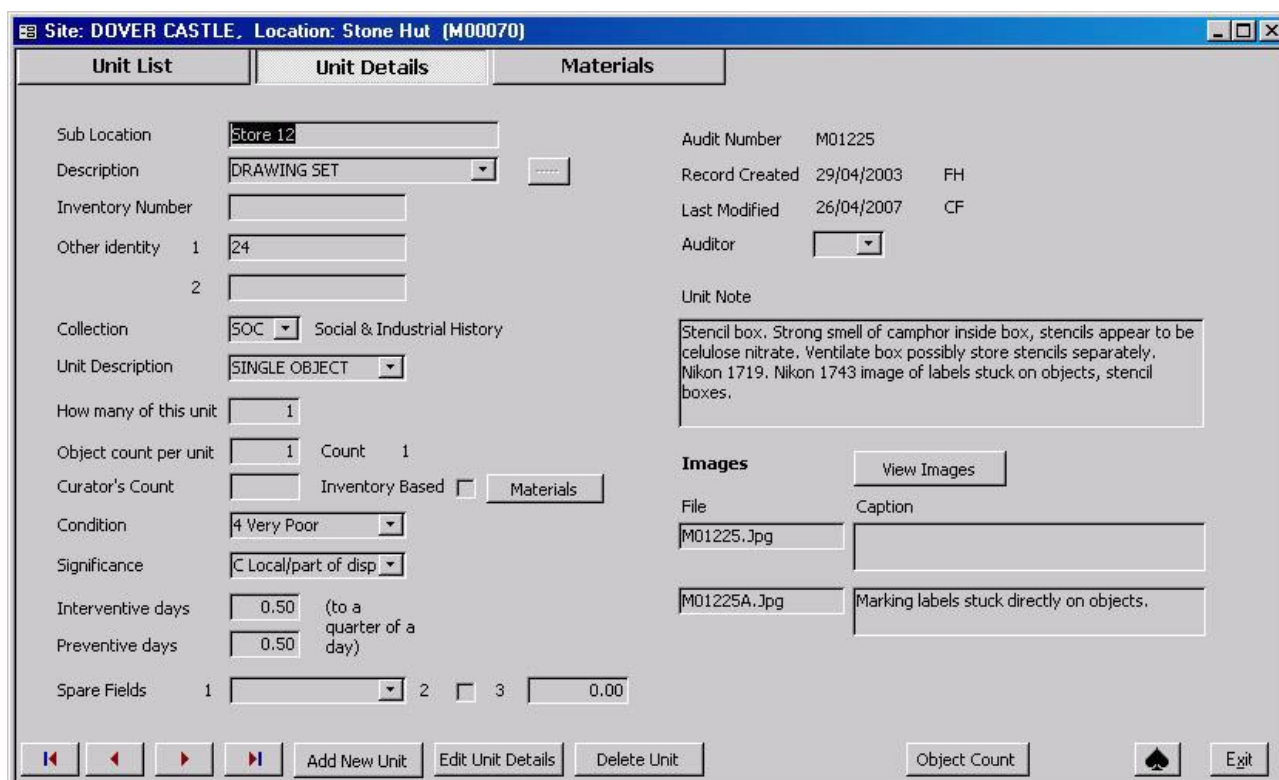

Figure 2. Screen of the audit showing the unit details.

For each location the first part of the process is to count the individual objects and/or 'units'. Units are used to simplify the counting of similar material, for example, a library full of books may be counted as shelves of books instead of individual books. The units or objects are counted as different collection types, archaeology, books and archives, decorative arts, ethnography, fine art, natural history and social and industrial history to enable the data to be subsequently analysed by these groups.

SAMPLE SELECTION METHOD

When the count is entered into the audit software, it will then calculate the number of objects or units in each collection type to be examined. A sample of 5% was chosen for a mixed collection and 2% for a store of similar material, for example, architectural stone fragments. Although it is understood that this sample is not statistically high enough to produce completely reliable and repeatable results, the cost and time implications of carrying out a condition audit on a larger sample across the 136 sites, would make the process too long and too expensive to undertake. Furthermore, the auditors' experiences of other condition surveys demonstrated that this sample size does produce useful information that is representative of the collection as a whole. If the audit identifies that damage has been seen on similar materials in a collection, it will recommend a 100% audit of that part of the collection is carried out.

The selection of objects/units to be audited is carried out by a random number generator incorporated into the software. A consistent method of counting is used to aid identification of the objects in the sample.

CONDITION SURVEY

The condition audit records basic identifying information about each object plus the material(s) from which it is made. The presence of damage to each material is then assessed and recorded. Only damage caused by the present conditions is considered, as the audit seeks to identify and address causes of current damage. For example, scratches to a table caused by historic use are not recorded, but scratches caused by a recent hospitality event would be. It can sometimes be difficult to determine what is current damage, but we rely on the judgement of highly experienced conservators. Damage types for each material are then selected from drop down lists. For example, for iron, damage types include active corrosion and flaking; for paper, tears and fading are among the options. New damage types can be

added if there is no appropriate term, but this is only done when absolutely necessary to keep changes to a minimum and to ensure that terminology is used consistently.

The causes of damage are then identified from a list that is the same as the risk factors used in the risk assessment. These are listed in Table 1.

For each type of damage noted, either preventive or remedial treatment, or both, is specified. For example, insect damage found on a piece of wooden furniture is caused by the risk factor, 'pests'. The treatments might include, treat infestation and improve integrated pest management. Although perhaps only one object in a room might be selected as part of the sample to be audited, a finding such as pest activity would highlight the need for further assessment and appropriate action for the whole area.

The decision was taken to use the causes of damage listed above rather than the nine or ten agents of decay, developed by Michalski [6] [7] and Waller [8], because these categories relate to the collection care systems and training provided by the Collections Conservation team [9]. If, for example, the highest risk at a site was identified as 'dust, dirt and handling', then an initial solution may be to send at least one member of staff on the Conservation Housekeeping course, run by English Heritage, Centre of Sustainable Heritage, UCL, which trains people how to handle and appropriately clean historic collections. However, having different causes of damage under one heading has proved difficult when carrying out the risk assessment, as will be discussed later.

The time needed for preventive and remedial conservation is given. Although the audit cannot give the precise amount and details of all remedial conservation needed at a site, as this would require a 100% audit, a very rough but still useful estimate can be gained from the sample audited.

A condition score is recorded, ranging from 1, meaning very good condition to 4, very poor condition. As a means of helping to prioritise the use of resources the significance of the object is also assessed. This can range from internationally significant to something with little or no significance, that might be considered for disposal. Although the auditors use their knowledge and judgement to assess significance, this field can be edited later by the curators, whose knowledge and understanding

of the collections allows them to make a more informed evaluation of significance.

A notes field allows additional information on the object to be recorded. A photograph is taken of each object audited to aid future identification, illustrate damage and, in some cases, to help monitor its condition.

The condition audit, even at 5%, can take several days to complete for a large site, but by the end, the auditors have examined a variety of materials in the collections and have a sound understanding of the damage occurring within the collection. This knowledge can be used as a basis for the risk assessment.

RISK ASSESSMENT

Before the risk assessment can be carried out, a thorough inspection of the site is made and a member of the site staff is asked a set of questions relating to maintenance of the site and the collection care systems in place. These questions correspond to the headings of the causes of damage/risk factors listed above. For example, for humidity, the questions include whether the site staff have been on the Light and Humidity course, if there is appropriate monitoring in place, if there is a control method in place e.g. heating, dehumidification, silica gel or a controlled case and if there are written procedures in place for checking data or replacing silica gel.

The risk assessment is carried out by discussion with all of the auditors who have worked on assessing that location. The yes or no answers to the questions are entered onto the audit database. Initially, the answers were weighted so that a negative answer, usually indicating that a collections care system was not in place, would cause the risk score for that risk factor to increase. However, as each risk factor had a different number of questions and it proved impossible to make the questions equal, the weighting was removed after the pilot run. The questions help the auditors evaluate the risks by clarifying which collections care systems are in place and whether they are working. For example, if insect pests are considered a risk, as the environment suggests that an infestation is possible, but the site has an effective integrated pest management system in place, this will be taken into account when entering the risk data. The second advantage of answering the questions is that when the audit is complete, the database will be able to reveal the number of sites with particular collection care systems in place. This has already

proved useful for determining how many sites have trained staff and which courses are most needed. The third, and biggest, advantage of answering the questions is that for every 'no' answer, the software forces the auditor to enter a solution, with a cost. The solutions are not pre-determined, so a solution specific to the site can be given.

The risk assessment is divided into the headings of the risk factors/ causes of damage listed in Table 1. The first question is the probability of damage. Will that risk cause damage in 1 to 3 years, in 4 to 10, 11 to 30 or 31 to 100 years? The second issue to consider is how much of the collection will be affected by that risk, few, some, most or all. Finally, the loss of significance to the collection if that risk causes damage is defined as minor, significant or major. The significance is judged by the value of the object to English Heritage. This can be historical, research potential, importance to display/ interpretation of the site and financial. The loss to the significance has to be carefully considered for each risk and type of collection. For example, the loss of documentation for a well known object, such as the Rembrandt at Kenwood, would not be as much of a risk to the significance of the object as loss of documentation for an archaeological soil sample. Without documentation, the Rembrandt would still be identifiable and can be displayed as a work of art, keeping its significance. However, without knowledge of which site and context the soil sample comes from it loses its research potential and therefore its significance.

As mentioned earlier, if a risk factor heading is broad, the risk assessment can be problematic. For example, dust, dirt and handling comprise a combination of risks that have different impacts. Damage from dust compared with poor handling could occur in a shorter timescale, affect more of the collection, but result in less damage; however, both types of damage may need to be considered in the same risk assessment. This was a particular issue for carrying out the risk assessment for disaster as every event from a school child drawing on an object in pencil, to a major fire comes under this heading. To overcome this, the auditors decide what is the most likely disaster based on the questionnaire and inspection of the property and the risk assessment is carried out for the selected disaster only.

USING THE AUDIT

The software produces two scores for each cause of damage/risk factor (listed in table 1), the damage

score and the risk score. The damage score was initially the percentage of the units showing deterioration caused by the damage factor. However, when it was decided to combine the risk and damage scores into an overall score, the damage score was changed to the percentage of units showing damage from a risk factor, out of the total number of units which contain materials susceptible to that damage factor. This was to take account of the quantity of collection at risk, referred to as the fraction susceptible, as this is part of the risk assessment. Previously information would be lost as, if only half the collection was sensitive to light, but all of those susceptible objects were deteriorating, the damage for light would still only be 50% maximum. In addition, only condition scores three and four are counted, as these record significant damage.

The risk score is calculated as:

Probability of damage x Quantity of Collection at Risk x Loss of Value

If there is more than one location at a site, the score for that location will be weighted by the number of objects at that location and the significance of the collection displayed or stored there. Although it would be ideal to treat all of the collections equally, with limited staff time and budgets this is unrealistic and priorities must be made.

A report is produced for each site and once auditing is completed, for each territory. A final national, 'State of the Collections' report will also be produced. The site report, after summarising the damage and risks, concludes with a prioritised table of solutions, with costs, and which department is responsible for undertaking the work. This could be the Collections Conservation Team, the Curatorial team, the Visitor Operations staff who run the site or Facilities, responsible for the maintenance of the building and services. A time scale was added, then had to be rethought as the predicted workload was unrealistic for the Collections Conservation team. Solutions are now described as needing to be carried out urgently, in the short-term or the long-term. The solutions are prioritised by using the damage/risk scores. However, some solutions to one risk will help reduce others. Cleaning of a chimney will reduce the source of insect pests, but may also reduce dust levels around the fireplace and aid ventilation and therefore improve the environment in the room. This is taken into consideration when ranking the solutions.

The Swiss Cottage Museum located in the grounds of Osborne House on the Isle of Wight, is an example of how the audit results have helped improve collection care. Osborne House is a large site composed of a mansion house and various small buildings. The audit was therefore divided into 3 locations with separate risk assessments. Interpretation of the data allowed for the prioritisation of collection care solutions across multiple locations pinpointing the collections at greatest risk and the appropriate action required (Appendix A). Insect pests in the Swiss Cottage collections were deemed the greatest risk due to the open nature of the built structure and the fact that many of the objects displayed there are made of organic materials. This was reinforced by a high damage score for pests, indicating a large number of the condition audits had identified active insect infestations. The risk was addressed by assembling a team who carried out a deep clean of the building and the collections. Many active insect infestations were discovered, verifying the results from the audit.

CONCLUSION

The EH combined Risk Assessment and Condition Audit is close to completion with all the major sites surveyed. Focus is moving from data gathering to the writing, promotion and implementation of site and regional reports. The audit results will guide the work of the Collections Conservation team for the next 10 years. In addition to the data in the site reports, the software has four further types of analysis report. Therefore, further interpretation of the data is possible, allowing any combination of the results. This is already being used to plan research into rates of deterioration. Other areas in which the audit results have already made significant changes include helping to make the case for regional conservator posts, emphasising



Figure 3. Cleaning cases in the Swiss Cottage Museum.

the need for improved emergency planning within EH and helping to identify training needs. The audit was also used to guide the collections care work at Apsley House, which became the responsibility of English Heritage in 2004.

Once the audit is completed, one version will be archived as a snapshot of the collection at this time. A second version will be updated as solutions are implemented to track progress and aid ongoing collection care plans.

Investing in the design and implementation of a combined Risk Assessment and Condition Audit is proving to be a key tool towards improving our understanding of the influence of the environmental conditions on the rates of deterioration and how to address these risks in a systematic way. It is also providing a convincing independent assessment used to influence management of the priorities and investment required to safeguard the collections.

ACKNOWLEDGEMENTS

Gratitude goes to all colleagues who have contributed to the EH Risk Assessment and Condition Audit and to Joel Taylor for his ideas and continued input.

AUTHORS

Claire Fry and Amber Xavier-Rowe
English Heritage
1 Waterhouse Square, 138-142 Holborn
London EC1N 2ST
claire.fry@english-heritage.org.uk
amber.xavier-rowe@english-heritage.org.uk

Frances Halahan and Jennifer Dinsmore
Halahan Associates
38 Kitson Road
London SE5 7LF
halahan@dircon.co.uk

REFERENCES

- 1 Taylor, J. 2005, 'An integrated approach to risk assessments and condition surveys,' *Journal of the American Institute of Conservation* 44. pp 127-141
- 2 Keene, S. 1991, 'Audits of care: A framework for collections condition surveys,' *Storage*, ed. Norman, M and Todd, V. London: United Kingdom Institute for Conservation. pp 6-16.
- 3 National Audit Office, 1988, *Management of the Collections of the English National Museums and Galleries; Report by the Comptroller and Auditor General*. London HMSO.
- 4 Waller, R. 1994, 'Conservation risk assessment: A strategy for managing resources for preventive conservation,' in *Preprints of the Congress on Preventive Conservation Practice Theory and Research, Ottawa*. (London: International Institute for the Conservation of Historic and Artistic Works.
- 5 Ashley-Smith, J. 1991, *Risk assessment for object conservation*. Oxford: Butterworth-Heinemann.
- 6 Michalski, S. 1994, 'A systematic approach to preservation: Description and integration with other museum activities,' *Preprints of the Congress on Preventive Conservation Practice, Theory and Research, Ottawa*. (London: International Institute for the Conservation of Historic and Artistic Works, pp.8-11.
- 7 Michalski, S. 1990, 'An overall framework for preventive conservation and remedial conservation', *ICOM Committee for Conservation, 9th Triennial Meeting, Dresden*, pp 589-591.
- 8 Waller, R. 1994, 'Conservation Risk Assessment, A strategy for managing resources for preventive conservation,' *Preprints of the Congress on Preventive Conservation Practice, Theory and Research, Ottawa*. (London: International Institute for the Conservation of Historic and Artistic Works, pp.12-16.
- 9 The five courses the Collections Conservation team run in partnership with the Centre of Sustainable Heritage, UCL are: Conservation Housekeeping, Surviving a Disaster, Light and Humidity, Integrated Pest Management and Hospitality and Filming.

APPENDIX A. TABLE OF TOP 10 SOLUTIONS FOR OSBORNE HOUSE

Risk	Location	Solutions	Est. Cost	Lead	Timescale
Pests	Swiss Cottage & Museum	Visit by Insect pest consultant	£400	DL	Urgent
		Deep clean.		CS, MH	Urgent
Light	House	Light plan		DT	Urgent
		Blinds in Duchess of Kent's Suite	£180	MH	Urgent
		Check UV absorbing film and replace if necessary	Approx £10000	DT	Urgent
		Improve monitoring	£200	DT	Urgent
Display/ Storage Conditions	Basement	Move store (too small, bad environment and risk of flooding)	£2000	MH, CMT	Urgent
		OR Re-fit store	£2000	MH, CMT	Urgent
		Purchase new packing material	£1000	MH,CS	Urgent
Disaster	Swiss Cottage & Museum	Check fire detection system is up to date		David L	Urgent
		New salvage equipment.	£1000	AL	Urgent
		Update salvage list.		MH	Urgent
Dust/Dirt & Handling	Basement	Include in housekeeping schedule		SC,CS	Short-term
		Reorganise		MH	Short-term
		Deep clean		CS, MH, SC,VH	Short-term
		Cover collection	£500	MH	Short-term
Pests	Basement	Increase monitoring	£10	David L	Short-term
Humidity	Basement	Move store			Short-term
		OR monitor and control	£400+	DT	Short-term
Light	Swiss Cottage & Museum	Review blinds	£400	DT	Short-term
		Check UV absorbing film, replace if necessary	Possibly £500	DT	Short-term
		Introduce monitoring	£500	DT	Short-term
Documentation	Swiss Cottage & Museum	Ensure all objects are labelled with an inventory number and entered, along with the label information into HOMS		MH, TR	Short-term
Dust/Dirt & Handling	Swiss Cottage & Museum	Include on housekeeping schedule		VH,SC, CS	Short-term
		Purchase housekeeping equipment	£500	CS	Short-term
		Dust proof cases?		DT	Short-term



This work is licensed under a Creative Commons Attribution - Noncommercial - No Derivative Works 3.0 Licence.

APPLYING THE OUTCOME OF CLIMATE RESEARCH IN COLLECTION RISK MANAGEMENT

AGNES W. BROKERHOF

ABSTRACT

Studies into the deterioration of materials due to interaction with their surroundings can provide insight into the mechanisms and rates of decay and lead to the development of solutions for conservation problems. The ultimate application of our understanding seems to be the definition of guidelines and standards, but the direction of collection risk management is a much more interesting way to use the outcome of our research. The need for data to predict future change in material confronts us with deficiencies in knowledge in the areas of statistics on probability of catastrophes, incident frequencies, rates of decay, the severity of the consequence or dose-effect relationships, and sustainable solutions. These are the areas in which collection risk management tells us to focus our research efforts. Does that make sense?

INTRODUCTION

Over the past decades, numerous studies have been published on the changes in materials due to interaction with the museum climate. These studies provide information on why, how and how fast those changes happen. They help us explain what we observe in our collections or they warn us that we may have a potential problem. Understanding mechanisms of decay enables us to think of methods to slow down the process or even prevent it from happening. Sometimes someone has the courage to compile the available literature, work out dose-effect relationships, and formulate 'safe levels' or set 'limits of exposure'. The ultimate use of our research results seems to be the definition of guidelines or even standards.

And then the brain goes numb. As soon as we have distinguished 'safe' numbers we cling to them and tend to forget where they came from or what they mean. Technology takes over when it comes to solving conservation problems. We have climate control equipment that can dry even museums in the tropics to the mythical value of 50% RH. We can dim the lights to less than 50 lux. But why did we want to do that?

This paper is written to reflect on the research that has been carried out in the area of museum collections and indoor climate. Which types of research have we been focussing on? What do we know by now and how do we apply our knowledge? Then it investigates how else we can use the results of valuable research in the context of Collection Risk Management, where, in combination with observations in practice, we try to explain the past, assess the present and predict the future. We can apply our knowledge to rank risks for our collections. But do we know enough? Does our research provide the 'right', applicable, data? Or do we have to re-focus our efforts? Hopefully, this paper stimulates debate on how to get the most value out of our research.

TYPES OF CLIMATE RESEARCH

Looking at the area of museum climate, air quality and light, I can distinguish four types of research (fig. 1).

1. MECHANISMS OF DECAY

Most research related to conservation problems starts with a study of the mechanisms of decay, to understand the phenomena that we observe; the 'what', 'why' and 'how'. For relative humidity (RH) and temperature (T) we have distinguished three situations that are 'wrong': too low, too high and too large fluctuation. The interaction between materials and an incorrect climate can be chemical (hydrolysis,

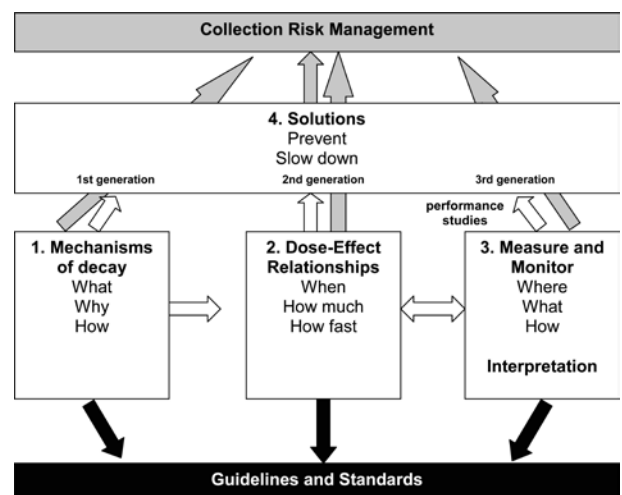

Figure 1. Types of research in the field of museum (micro) climates.

oxidation), mechano-physical (stress, melting) or biological (mould). With this understanding we were able to develop what I call the first generation solutions to conservation problems – try to keep a constant RH (which became ‘the smaller the fluctuations, the better’), make sure RH is not too high and not too low. This type of research can provide us with useful information on rate of decay, enabling us to estimate ‘expected life time’, ‘mean time to failure’ and to draw ‘isoperms’ [1, 2]. But it usually does not tell us how low is too low or which fluctuations are really too large.

2. DOSE-EFFECT RELATIONSHIPS

Therefore, a next step is to look at the dose-effect relationships. The influence of other parameters can be included here and synergistic effects can be studied. This provides a better understanding of what happens so that second generation solutions can be developed. Formation of lead acetate corrosion can be stopped by removing the source of acetic acid, but it can also be slowed down to an acceptable level by lowering the acetic acid air concentration to a safe level (ventilation) and by reducing the relative humidity. Now we have a choice of options to solve the problem and flexibility in our approach. Key papers are the studies into the effects of RH fluctuations on wood by Erhardt et al. [3] and Bratasz et al. [4], the effects of T and RH on ageing of paper by Graminski et al. [5] and Zou et al. [6], and on acetate film by Reilly [7].

3. MEASURE AND MONITOR

Once we understand dose-effect relationships, but also to increase understanding of these relationships, we need to measure and monitor the environment. RH, temperature, light and indoor air pollutants are good examples of agents of deterioration that have been measured extensively. We can measure numbers and link them to effects, like % RH, or we can determine the effect directly with dosimeters, like the blue wool standards and more recently developed air quality dosimeters [8, 9] and light dosimeter [10], or surrogate materials and early warning systems.

We also use measuring studies to determine the performance of our remedies. Here it strikes me that the interpretation of measurements is often less detailed than the measuring itself. For an explanation of how the inside climate relates to the outside climate, the role of absolute humidity and vapour pressure, evaluation of the performance of

a solution, we can turn to the work of for example Padfield [11] and Maekawa [12]. Proper measuring and interpretation can lead to further improved, third generation solutions of conservation problems.

4. STANDARDS AND GUIDELINES

And now it becomes interesting. The combination of understanding mechanisms, dose-effect relationships and monitoring can lead to the definition of ‘safe levels of exposure’, guidelines and even standards (here I focus on collections although most climate standards are a compromise between collection needs, human comfort and technical feasibility in buildings). Based on a selection of publications that are within our reach, grasp, and language skills, we can define safe levels, no observable adverse effect levels (NOAEL) or lowest observable adverse effect dose (LOAED) [13]. The ‘observable effect’ is determined by the available technology with which we observe, while the ‘adversity’ is determined by our acceptance of change, where not all change is necessarily adverse. If a book derives its main value from the information the text gives, a slight yellowing of the paper does not affect that informational value and may be acceptable. This is important to realise, because this means that our guidelines and standards are prone to adjustment in time. What we find acceptable now, may be unacceptable in the future, which means we have to redefine our standard (as is often being done in environmental and health safety). It can also go the other way. We may become more relaxed and realise that a generally accepted standard is based on extreme caution. We agree that fluctuations in RH are worse than a stable environment. But which fluctuations are really bad for our collections? Erhardt [3] and Bratasz [4] provide us with theoretical studies and practical experiments, but still we cannot agree on where the limits are for wood, let alone for the large variety of not yet studied materials.

Process standards that describe, for example, that light levels should be measured, how to do that, and how to interpret the results, provide guidance towards good working practice. Numerical standards on the other hand are restrictive, leaving little room for flexibility. The numerical ‘50 lux standard’, suggests that 49 lux is safe and 51 lux is detrimental. Based on detailed and nuanced knowledge about light and light sensitivity, a rigid level has been defined that enables the non-nuanced mind to transfer responsibility to the standard. That is really a waste of knowledge because a good understanding of dose-effect relationships provides

the opportunity to develop a flexible approach to exposures. For example light: a higher illuminance can be acceptable as long as the duration of exposure is reduced so that the dose of lux multiplied by hours of exposure remains in the acceptable range. Ideally, our knowledge should lead to guidelines which describe these dose-effect relationships and leave flexibility for intelligent interpretation. After all, we all like to take our own responsibility when it comes to crossing the street, ignoring the red traffic light when there is no immediate risk, even though the standard says ‘red = do not cross’. We gladly turn that particular standard into a guideline.

Fortunately ASHRAE [14] and the new lighting guidelines [15] are based on that flexible approach. It is most interesting to experience that conservators and collection managers, who have to specify their requirements to the designers and engineers, call on advisers to ask for numbers, because the guidelines are too difficult and not useful. Do they not want to take responsibility for their own decisions and specifications or should we put more effort in embedding the guidelines in museum practice, in teaching how to use them, and in providing tools to apply the guidelines with confidence?

RISK, COLLECTION RISK ASSESSMENT AND COLLECTION RISK MANAGEMENT

For me numerical standards lead to a dead end and ultimately to a loss of intelligence. So, which other way could we go? Instead of defining standards we can develop a working method to rank and prioritise our conservation needs and mitigate the most relevant in a cost-effective manner: collection risk management. In my opinion this is where our knowledge can be applied much more effectively. Before discussing how, I will provide some background on risk, risk assessment, and risk management.

RISK

The goal of collection management can be defined as ‘delivering the collection to some point in the future with as much value as possible’ [16]. It involves making well informed decisions to prioritise and allocate resources to optimize the value of our collections, be that through increasing the value (development) or through minimizing the losses (preservation), while one needs access to and use of collections to justify one’s reason for existence or to generate revenues to be able to invest anything at all

[17, 18]. One of the means to minimize loss of value, or to maintain value, is (preventive) conservation. To prioritise our actions and spending we need to determine what are the biggest or most urgent risks to our collections.

Risk is defined as the ‘possibility of loss’. Risk is usually looked at as the product of the likelihood or probability that a harmful event or process will happen, and the consequence, impact or effect of that event or process: Risk = Probability x Consequence. The likelihood or probability refers to the chance that a particular event may take place, to the frequency with which incidents happen or to the rate at which degradation processes take place when given the chance. The consequence can be expressed by considering how much of a collection could be affected and ‘how bad’ the impact will be. This is expressed as ‘loss of value’, where value is not just monetary value: it can be anything from cultural, historical, educational to emotional. Thus risk becomes the ‘possibility of loss of value’ or the ‘expected loss of value’ in a certain period of time [17, 18].

COLLECTION RISK MANAGEMENT

After establishing the context for risk management, the first part of risk management is an assessment of all risk, which consists of several steps (fig. 2) [19, 20]. It starts with identifying a diversity of risks that will include all plausible risks. That means not just the obvious ones and those that have proven to be risks in the past, but also the invisible and not yet experienced risk. Consequently, analysing the risks involves developing scenarios which describe the chain of events from cause to effect. Then the specific risks can be evaluated and compared. The Australian-New Zealand Standard for Risk Management [20] (N.B. an example of a useful

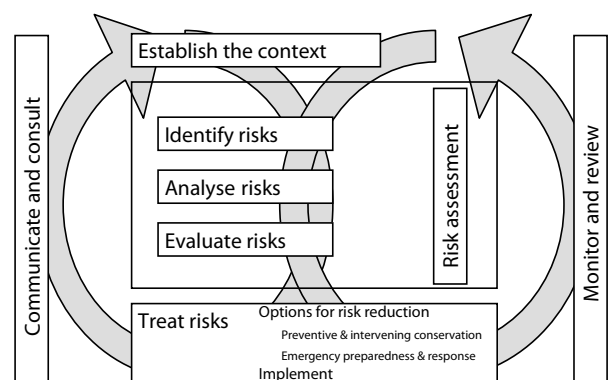

Figure 2. Schematic representation of Risk Assessment and Risk Management (after: Australian/New Zealand Standard, AS/NZS 4360:2004).

process standard) provides examples of various ways to evaluate risks, varying from quantitative, through semi-quantitative to qualitative. In practice the choice of a particular method will depend on the quality and certainty of the available data for likelihood and impact. In the field of cultural heritage, Waller has developed the Cultural Property Risk Analysis Model which uses quantitative fractional numbers [18]. Several organizations have already applied his model in practice [21-23]. Michalski has proposed a semi-quantitative set of simple scales [24]. Currently, CCI, ICCROM and ICN have a partnership in which they, together with Waller, develop tools and resources for risk assessment. Within this partnership CCI has taken the lead to develop a user-friendly model for risk assessment. Whichever system for risk assessment and evaluation is used, the result is a more or less rational ranking of risks based on their expected magnitude. This allows setting priorities in treating or reducing the risks. If conducted properly the outcome of a risk assessment provides an organization with credible and convincing results that enable well considered decision-making.

The second part of risk management is treating or mitigating the relevant risks. We think about the most cost-effective way to reduce the risk to an acceptable level. This is where the studies into the development and performance of solutions become relevant. We may understand the effectiveness of mitigation options but the cost aspects are often vague. How much does it cost to narrow RH fluctuations from a bandwidth of 15% to 10%? Is the preservation benefit of a narrow range worth the extra cost? Management decisions will often be made on the basis of economic arguments. Here we should also keep in mind the trend towards sustainable solutions, a field in which Cassar and her team are important players [25].

RISK SCENARIOS AND SCENARIO POOL

Doing a risk assessment involves developing scenarios for the identified risks. A scenario describes a specific risk so that it can be assessed. It tells the story about what is expected to happen in a given context, location or situation, from the beginning (the hazard or source) to the end (the loss of value), taking into account all mitigating and magnifying factors. To quantify the risk, we use the current knowledge about probabilities, rates and impact. Thus the scenario requires mining the huge source of scientific data that is scattered around the world, contains examples of which data is available, where to find it, and how to use it.

Experience in applying and teaching risk assessment of heritage collections demonstrates that an important resource for assessors is a pool of scenarios made by experts in real situations. As a spin-off from the CCI-ICCROM-ICN courses 'Preventive Conservation – Reducing Risks to Collections' (2003-2007) ICN has taken the lead in developing a set of reference scenarios, the 'Scenario Pool'. The 'Scenario Pool' started in 2006 as an exercise in writing unambiguous scenarios and in developing a consistent working practice for the course teaching staff. The scenarios, template and guidelines for scenario writing that resulted from that exercise are now used as teaching material. Meanwhile the scenario pool has the potential to become a tool for compiling data on specific risks. As the scenarios are discussed and peer reviewed they offer a basis for growing and expanding knowledge. For users who find themselves in slightly different circumstances, the reference provides directions for how and where to find applicable data. Since scenario writing focuses the author on available data, it confronts one also with the lack thereof. Thus the scenario pool could help define areas for future research for the participating institutions.

AVAILABLE DATA FOR RISK ASSESSMENT

What has our experience been so far with the availability of applicable data from climate research for scenario writing? Somehow we have to predict material change over the next decades; both the likelihood and the consequence. The second step is to translate that material change into a change in value, where a change in material may not always prove to be a loss of value. Our main sources for data on both likelihood and consequence are: incident reports, statistics, and conservation science. Our starting point to identify risks is the collection itself. It tells us about risks that have already manifested themselves. We can look for damage and deduce its cause. This is information provided by our condition surveys in combination with our experience of interpreting 'what the collection tells us'. That interpretation is fed by the results of our studies into mechanisms of decay and dose-effect relationships, guided in the right direction by the results of our monitoring. We seem to have become quite good at this, but we actually make many mistakes if we are not aware of our own biases in observation and interpretation. Looking closely at the procedures and working processes within an institution, usually by conducting staff interviews, can give us data on the frequency at which incidents occur. Practice shows that there are actually very few institutions

that systematically record their incidents, let alone their near-incidents. Hence, there is uncertainty in the data to predict incidents at an institutional level in the future. For example, how often do water pipes burst?

When incident data from within the institution is lacking, we may resort to using data derived from a more general level. Thus, our second source for data consists of regional, national or even international statistics. This source is especially relevant for catastrophes such as flood, fire and theft. They do not happen frequently enough to generate reliable data within a single institution. But even on a national level, it is not easy to find good sources for this type of information. Recently Tétreault has generated very useful data on fire in Canadian museums from a risk management perspective [26].

For the continuous processes that cause mild but accumulating change, we have a third source of data: the results of our scientific research. We are interested especially in the studies that provide information on the rate of degradation, either from studying the mechanism of decay or the dose-effect relationships. But we also need insight into the actual consequence. How many sheets of paper in an acid box turn yellow due to acid hydrolysis? Despite the huge body of literature, there actually seems to be only a limited number of useful and applicable publications. They are even used to predict changes in materials that were not included in the original study.

In addition to this 'objective' data about probabilities, frequencies, rates and material properties, the 'subjective' side of risk assessment, translating material change into loss of value, is an area where there is definitely a lot of work to be done [27, 28]. Developing frameworks for valuation and determining loss of value goes beyond the scope of this paper, but it is in my opinion the most interesting part of the discussions between all those involved in collection risk management.

CONCLUSION

All the different types of climate research we have conducted through the years have provided us with a reasonably good insight and understanding of mechanisms, dose-effect relationships, techniques to measure and monitor, and solutions for our conservation problems. The ultimate application of the outcome of those studies is the definition of guidelines and standards. Although hard numbers

are needed in, for example, building contracts specifications, these should be derived from intelligent use of insight and understanding instead of transferring responsibility for the consequences of one's decision to an anonymous number from a numerical standard.

In the systematic approach of collection risk management, we use the results to predict material change in the future. We translate this material change into a loss of value. This enables us to rank the various identified risks according to their potential loss of value. We can then decide what are the biggest risks, the risks with the highest uncertainty or the risks with a common cause, and develop cost-effective options to reduce those risks. We use our collective knowledge to make well-argued proposals to mitigate the risks that really matter. It allows us to develop tailor made solutions for a particular problem rather than applying somebody else's best practice. This means we can reach the optimum result at minimum cost.

Writing scenarios to enable us to qualify or quantify risks, confronts us with a lack of data about the probability and frequency of events - incident reports, (inter)national statistics - together with a lack of knowledge about the actual consequence of any particular event. How much of our collections get wet in case of flooding and how much damage does that cause? We also still lack data on rates and consequences of decay processes for various materials. Another relevant topic is the cost-benefit analysis of (sustainable) solutions for climate problems. Does collection risk management tell us that we, as a research community, should focus our efforts on even more relevant topics than we have done so far? I leave that question open for discussion.

ACKNOWLEDGEMENT

The development of courses, tools and resources for risk assessment described in this paper takes place within a partnership between CCI, ICCROM and ICN with contributions from a number of other experts. I would like to acknowledge the cooperation with Stefan Michalski and Jean Tétreault (CCI, Ottawa), Catherine Antomarchi, José Luiz Pedersoli Junior, and Isabelle Verger (ICCROM, Rome), Bart Ankersmit and Frank Ligterink (ICN, Amsterdam), Robert Waller (Canadian Museum of Nature, Ottawa), Veerle Meul (Monument Watch, Antwerp), Vesna Zivkovic (National Museum Belgrade) and Jonathan Ashley-Smith (Freelance consultant,

London). These are also the people that currently form the 'scenario pool team'. Once the start-up problems have been solved, the entire network of former course participants and others involved in risk assessment should be involved in creating a large, open pool where knowledge can be shared so that the risk management community can profit from each other's experience.

AUTHOR

Agnes W. Brokerhof. Senior Scientist,
Conservation Research Department
Instituut Collectie Nederland (ICN, Netherlands
Institute for Cultural Heritage)
P.O. Box 76709, 1070 KA Amsterdam, The
Netherlands
agnes.brokerhof@icn.nl

REFERENCES

- 1 Sebera, D.K. (1994) 'Isoperms: An environmental management tool', Commission on Preservation and Access, Washington, D.C. (also: <http://www.clir.org/pubs/reports/isoperm/isoperm.html>)
- 2 Michalski, S. (2002) 'Double the life for each five-degree drop, more than double the life for each halving of relative humidity'; in: *Preprints of the ICOM-CC 13th Triennial Meeting, Rio de Janeiro*, James and James, London, pp. 66-72.
- 3 Erhardt, D., Mecklenburg, M.F., Tumosa, C.S., and McCormick-Goodhart, M. (1995) 'The Determination of Allowable RH Fluctuations'; WAAC Newsletter, 17(1), pg.19 (also: <http://palimpsest.stanford.edu/waac/wn/wn17/wn17-1/wn17-108.html>)
- 4 Bratasz, L., Jakiela, S., and Kozlowski, R. (2005) 'Allowable thresholds in dynamic changes of microclimate for wooden cultural objects: monitoring in situ and modelling'; in *Preprints of the ICOM-CC 14th Triennial Meeting, The Hague*, James and James, London, pg. 582-589.
- 5 Graminski, E.L., Parks, E.J., and Toth, E.E. (1979) 'The effects of temperature and moisture on the accelerated ageing of paper'; in: *Durability of Macromolecular Materials* (R.K. Eby, ed.), American Chemical Society (ACS Symposium Series 95), Washington DC, p. 341-355.
- 6 Zou, X., Uesaka, T., and Gurnagul, N. (1996) 'Prediction of paper permanence by accelerated aging I. Kinetic analysis of the aging process'; *Cellulose*, 3:243-267.
- 7 Reilly, J.M. (1993) 'IPI Storage Guide for acetate film'; Image Permanence Institute, Rochester, 24 pp. (also: http://www.imagepermanenceinstitute.org/shtml_sub/acetguid.pdf and http://www.climateenotebook.org/Tfp/Software/Software_PresCalc.html)
- 8 Dahlin, E., Grøntoft, T., Rentmeister, S., Calnan, C., Czop, J., Hallett, K., Howell, D., Pitzén, C., and Sommer Larsen, A. (2005) 'Development of an early warning sensor for assessing deterioration of organic materials indoor in museums, historic buildings and archives'; in *Preprints of the ICOM-CC 14th Triennial Meeting, The Hague*, James and James, London, pg. 617-624.
- 9 Odlyha, M. et al. (2005) 'Microclimate indoor monitoring: damage assessment for cultural heritage preservation'; in *Preprints of the ICOM-CC 14th Triennial Meeting, The Hague*, James and James, London, pg. 670-676.
- 10 Lido Light Check dosimeter, see: <http://www.lido.fhg.de/index.html>
11. For collected work see: www.padfield.org/tim/cfys/
- 12 Maekawa, S., and Toledo, F. (2003) 'Sustainable climate control for historic buildings in subtropical climates'; *Management of Environmental Quality: An International Journal*, 14(3):369-382.
- 13 Tétreault, J. (2003) 'Airborne Pollutants in Museums, Galleries, and Archives: risk assessment, control strategies, and preservation management; Canadian Conservation Institute, Ottawa, 168 pp.
- 14 ASHRAE (2007) 'Museums, Galleries, Archives and Libraries'; in: *ASHRAE Handbook-HVAC Applications*, Chapter 21, American Society of Heating, Refrigerating and Air-Conditioning Engineers (ASHRAE), Atlanta, 23 pp.
- 15 CIE (2004) 'Control of Damage to Museum Objects by Optical Radiation'; Technical Report CIE 157:2004, Commission International d'Eclairage, Vienna, 29 pp.
- 16 Waller, R., and Michalski, S. (2005) 'A paradigm shift for preventive conservation, and a software tool to facilitate the transition'; in *Preprints of the ICOM-CC 14th Triennial Meeting, The Hague*, James and James, London, pg. 733-738.

- 17 Brokerhof, A.W. (2006a) 'Collection Risk Management – The Next Frontier'; Presented at the CMA Cultural Property Protection Conference, Ottawa, 16 January 2006, see: www.museums.ca/protection/en/presentations/Brokerhof.pdf
- 18 Waller, R.R. (2003) 'Cultural property risk analysis model: development and application to preventive conservation at the Canadian Museum of Nature'. Acta Universitatis Gothoburgensis, Göteborg, Sweden, 189 pp.
- 19 Waller, R.R. (1994) 'Conservation risk assessment: a strategy for managing resources for preventive conservation'; in: *Preventive Conservation – Practice, Theory and Research, Preprints of the Contributions to the Ottawa Congress*, 12-16 September 1994 (A. Roy and P. Smith eds.), IIC, London, pg. 12-16.
- 20 Australian/New Zealand Standard, AS/NZS 4360:2004 (2004) 'Risk Management'; Standards Australia & Standards New Zealand, third edition 2004, 30 pp. (Plus accompanying Guidelines, 120 pp.)
- 21 Baird, R. (2006) 'Sustaining institutional priorities through risk assessment – Canadian Museum of Nature'; Presented at the CMA Cultural Property Protection Conference, Ottawa, 16 January 2006. (also: www.museums.ca/protection/en/presentations/Baird.pdf)
- 22 Brokerhof, A.W., Luger, T., Ankersmit, H., Bergevoet, F., Schillemans, R., Schoutens, P., Muller, T., Kiers, J., Muething, G., and Waller, R. (2005) 'Risk Assessment of Museum Amstelkring: Application to an historic building and its collections and the consequences for preservation management'; in *Preprints of the 14th ICOM-CC Triennial Meeting, The Hague*, pp. 590-596.
- 23 Hughes, G. (2006) 'Collection risk assessment – Royal BC Museum'; Presented at the CMA Cultural Property Protection Conference, Ottawa, 16 January 2006. (also: www.museums.ca/protection/en/presentations/Hughes.pps)
- 24 Michalski, S. (2005) 'Simple scales that add up'; ICCROM-CCI Course 'Preventive Conservation, reducing risks to collections', Rome 2005.
- 25 Cassar, M. et al. (2004) 'Sustainable Solutions in the Conservation and Protection of Historic Monuments and Archaeological Remains: A Critical Assessment of European Research Needs', Centre for Sustainable Heritage, University College London, C. Saiz-Jimenez (ed.), pp. 249-261.
- 26 Tétreault, J. (2007) 'Fire risk assessment for collections in museums'; submitted for publication in *The Journal of the Canadian Association for Conservation*.
- 27 Ashley-Smith, J. (1999) 'Risk assessment for object conservation', Butterworth-Heinemann, Oxford, 358 pp.
- 28 Brokerhof, A.W. (2006b) 'The deterioration processes of organic objects in museum, historic house and archive environments'; Presented at the EU MASTER Final Workshop, UCL, London, 10 January 2006. (see: www.nilu.no/master/documents/3.The deterioration processes of organic objects-AgnesBrokerhof_000.pdf)



This work is licensed under a Creative Commons Attribution - Noncommercial - No Derivative Works 3.0 Licence.

DOCUMENTING AND OPTIMIZING STORAGE CONDITIONS AT THE NATIONAL MUSEUM OF DENMARK

JAMES M. REILLY, JESPER STUB JOHNSEN AND LARS AASBJERG JENSEN

ABSTRACT

New technology and approaches to environmental assessment in preventive conservation have been developed at the National Museum of Denmark (NMD) during a museum-wide project from 2004-2007. The Image Permanence Institute (IPI), a preservation research laboratory in the College of Imaging Arts and Sciences of Rochester Institute of Technology, Rochester, NY, USA was contracted by NMD to design and help conduct the assessment of storage conditions, working together with NMD staff. More than 240 locations were monitored in the course of the project, creating formidable difficulties with organization, analysis and reporting. To cope with these difficulties, a web database of environmental data and collection management information was created and given the name *MyClimateData*. An interface for this web site was devised, allowing for analysis of groups of locations via a hierarchy of site, building, floor, room and location, as well as through searches based on any type of collection characteristics saved in the database. Analysis of the 'preservation quality' of the environments was performed and reported using IPI's environmental metrics (algorithms for transforming temperature and RH data into numerical estimates for specific decay rates). The project was successful in helping NMD clarify its storage needs and future construction plans.

INTRODUCTION

In recent years increasing emphasis has been placed on the role of preventive conservation in museum management. There is general agreement that the foundation for successful interventive conservation programs is to apply collection management techniques that identify and minimize risks to collection objects, lengthening the useful life of collections and reducing the need for repair of preventable damage [1]. Another important trend in museum management is to divide collections into different categories based on value [2]. This is done to help ensure that resources for collections care and storage are applied in a fashion that reflects the cultural significance of collections and furthers the overall mission of the institution. It also helps focus

interest on the quality of storage conditions for the most valuable objects. Often such evaluations are done in conjunction with improvements in databases used for inventory and various other logistic functions. The common thread among all these trends is the need for tools and approaches that enable museums to set priorities, measure progress, and document good stewardship.

Measuring and analyzing storage conditions has for many years formed an important part of conservation management and preventive conservation of museum collections [3,4]. From the point of view of museum management, a reasonable expectation is that a monitoring project would result in useful, standardized determinations of the degree of risk—and benefit—posed by environmental conditions to the major types of collection objects, or even to single objects of great importance. Hygrothermographs, the traditional pen-and-chart type recording instruments for temperature and humidity data, have now been replaced in many museums by electronic data gathering. While electronic dataloggers offer many advantages over hygrothermographs, there are a number of remaining difficulties that make it very hard in practice for museums to assess the quality of storage environments. These can be summarized as a lack of staff time and expertise, the difficulty of determining the degree of risk (or benefit) to collections, and the challenge of organizing, maintaining, and reporting on mountains of data. (In large museums it is not uncommon to have hundreds of locations to monitor [5].)

In 2004 the National Museum of Denmark, a national cultural history museum with large and diverse collections, undertook a three-year effort to assess the preservation quality of its existing collection storage facilities. This effort was part of a larger strategic assessment of NMD's capabilities and priorities conducted with the support and encouragement of Denmark's Ministry of Culture. The environmental assessment and optimization project, now nearly complete, resulted in the development of a prototype for a web-based system of environmental assessment and reporting, together with a prototype of a web database for centralizing

collection management information. The web system was given the name *MyClimateData*.

The aims of the environmental assessment project at NMD were to determine whether existing facilities were delivering conditions appropriate to the collections stored there, to judge whether there was sufficient capacity overall to adequately preserve the important elements of the NMD collections, and to generate documentation of the need for improvements. The Image Permanence Institute (IPI), a preservation research laboratory in the College of Imaging Arts and Sciences of Rochester Institute of Technology, Rochester, NY, USA was contracted by NMD to design and help conduct the assessment of storage conditions, working together with NMD staff. This paper describes the project and in particular new methods of environmental assessment developed during its evolution.

PROJECT DESIGN

NMD staff from the Conservation, Conservation Research, Registration, and Storage and Logistics departments collaborated on a plan to monitor temperature and relative humidity in more than 200 locations among NMD's multiple sites and buildings in and around Copenhagen. The project also included limited monitoring in the Royal Library of Denmark, the Conservation Center in Vejle, and the Collection of antiquities in Ribe. The project involved acquiring 150 new Preservation Environment Monitor® (PEM) dataloggers as well as using existing Tiny Tag® portable dataloggers already owned by NMD. In addition, current and historical data from NMD's building management computer system (BMS) was included in the project. Data analysis was performed by IPI using its *Climate Notebook*® software. IPI's team working on the project included several staff scientists, a computer programmer, and a consultant with expertise in energy-efficient operation of heating, ventilation, and air-conditioning (HVAC) systems. The plan was to deploy the loggers and monitor storage conditions for at least a year to obtain a baseline of data showing the seasonal cycle. In the meantime, allied information necessary for the assessment task, such as the types of objects stored in each location, details of building construction, nature and capabilities of mechanical systems (if they existed) were to be gathered and stored in a MS Access® database.

The first lesson taught by the project was that strategic as well as tactical considerations must be considered in

all aspects of project planning and data analysis. Many different points of view must be taken into account in determining which spaces to monitor and how the analysis will be used. Curators, museum managers, collection managers, facilities staff, conservators and registration staff all have an interest in the data and conclusions resulting from the project. On the strategic level, the important objectives were to create a reasonable overview of storage conditions in the entire institution and to evaluate alternatives in the design of future storage facilities. On the tactical level, there were many previously unmonitored locations as well as those with known environmental defects that NMD staff wanted to explore in greater depth. There was also a need to ensure that certain collections and significant objects were included, and that important curatorial and administrative units were not left out. Even with more than 200 data collection devices, there was concern about missing coverage of the many spaces and buildings owned by NMD. In the end, the number of data collection devices was not enough to cover every location of interest, but was sufficient to obtain a strategic overview and to serve most of the tactical objectives.

DIFFICULTIES WITH DATA

The main difficulty was not lack of dataloggers but lack of organizational tools to help plan and execute a project so large and to keep track of data and information. NMD staff knew the museum and its collections well, and had kept very good documentation of collection management information. Initially it was thought that simple spreadsheets and databases would be enough to track where dataloggers were, when data needed to be uploaded, and so on. Analysis and reporting were planned to be done with IPI's *Climate Notebook*® software, which had been designed to evaluate data sets one at a time, or in small groups. It soon became apparent that everyday tasks of working with environmental data files (naming of folders and files, matching data sources, updating files, etc.) as well as the larger task of analysis and interpretation of data were rather time consuming and difficult, when extended to hundreds of data sets. Naming locations with unique but meaningful identifiers is vitally important in project design because the location name is the key upon which all the retrieval and interpretation of data depends. In this project, a naming scheme was ultimately chosen that incorporated coded information about the site, building, floor, room and data source (logger or BMS system).

Custom programming was required to reconcile the data formats of the three main data-gathering

devices used in the project. The PEM® data could directly be used in *Climate Notebook*®, but data from the BMS systems and Tiny Tag® dataloggers could not. Museums considering similar projects and having several different data sources should be aware of the difficulties of incompatible data formats.

INTERPRETING ENVIRONMENTAL DATA

After some months, the initial organizational phase of the project was concluded and data began to be collected. At this point we realised that a formidable challenge lay ahead in the task of analysis and reporting. Analysis on the strategic level meant quantitatively determining and comparing the degree of risk or benefit that environmental conditions pose to collections and using that information to determine storage needs and to determine if preservation goals are being met. The strategic level of analysis obviously requires joining multiple locations into composite overviews for a building, a department, a site, or the entire institution. The tactical level of analysis is concerned with similar estimations of risk but also with understanding what factors (climate, mechanical systems, water leaks, rising damp, building characteristics, etc.) influence a particular environment and what might be done to improve it (modify set points, install new equipment, remove collections entirely, etc.). To meet the NMD project's goals, both types of analysis were required.

In both strategic and tactical analysis the observed environmental characteristics are merely the starting point for evaluation of the preservation quality of a storage or display space. The nature and needs of collection objects present in the space must be taken into account. The value and importance of objects and collections also must be considered. As research has made clear, there is no single environmental condition that is benign and optimal for all collection materials [6,7,8]. Collections and individual objects often have multiple deterioration mechanisms. It is necessary to consider risks arising from specific decay mechanisms,

and then prioritize which mechanisms are important to the deterioration rate. Preventive conservators should not forget that they need to measure and demonstrate successful stewardship of collections as much as they need to diagnose problems and risks.

METRICS FOR ASSESSING ENVIRONMENTALLY-INDUCED COLLECTION RISKS

The starting point for analysis of environmental data in the NMD project was the use of environmental metrics. These are algorithms that transform temperature and RH values into quantitative predictions of the likelihood and severity of specific forms of collection decay. These algorithms have been developed by IPI over the last several years and have been refined in the course of the NMD project [9, 10, 11]. Environmental metrics enable a concise, standardized overview of the characteristics of environmental conditions. The names and types of decay mechanisms addressed by the metrics are given in Table 1. Each of these metrics yields a number that is an estimate of the tendency of the environment to cause or prevent collection deterioration via a specific pathway (mould, corrosion, etc.)

The metrics are intended to be one tool among many techniques and approaches used by preventive conservators and collection managers in dealing with environmental analysis and reporting. Metrics describe general characteristics of conditions in a standardized way. They save time in dealing with large amounts of data by providing a rapid screening for particularly dangerous conditions. To use the metrics in practice one must be familiar with how they are calculated and have a feeling for the meaning of the numerical values that result from them. One must also know what sorts of collection materials are present and must consider which forms of deterioration—and therefore which of the metrics—will be given the most weight in

Metric	Deterioration Type	Basis for Analysis	Algorithm
TWPI	Spontaneous chemical change in organic materials	Generalized treatment of hydrolysis reaction kinetics	Integrates over time, weighting each time interval according to the reaction rate
Mould Risk Factor	Mould	Based on empirical studies with food grains	Integrates over time, creates running sum of progress toward mould germination
Dryness	Shrinkage and stress related damage in wood, leather, etc	Based on physical behaviour of an averaged wood species	Estimates moisture content using moving averages of T & RH
Dampness	Expansion and compressive stress related damage in wood, leather, etc.	Based on physical behaviour of wood	Estimates moisture content using moving averages of T & RH
Dimensional Change	Fatigue and stress related damage in wood, leather, etc.	Based on physical behaviour of wood	Estimates dimensional change based on moisture content
Corrosion	Metal corrosion	Moving average RH value	Two levels of severity based on adjusted RH

Table 1

the analysis. Metrics can yield a quick overview of multiple locations by creating a ranked list from best to worst from the point of view of a particular type of deterioration. For an individual location, metrics can be used to determine whether the collections actually present are at risk, or else what types of collections might be stored there with minimal risk. In the NMD project the metrics proved especially useful in developing overviews of conditions organized by building, department, and collection type.

DEVELOPMENT OF A WEB DATABASE AND WEB INTERFACE TO CLIMATE DATA

The original intent of the project was to perform all analysis and reporting using Climate Notebook® (CNB) software. As the project developed, the limitations of this software when applied to such a large monitoring effort became apparent. Although the CNB software was a powerful tool for manipulation and analysis of data, it was organized around dealing with one location at a time, or at most a group of 20 locations. CNB allowed for a certain amount of information to be kept alongside the environmental data for a particular location, and did allow for computation and display of the environmental metrics listed above, but the need for a more robust and flexible database to organize the large-scale monitoring and analysis effort became quite clear. Something had to be done to ease the formidable organizational difficulties resulting from naming, filing, modifying, and reconciling separate small databases containing various elements of the assessment project. It also was apparent that a number of people throughout the museum needed access to the environmental data as well as to the associated database of information about the collections.

The project team then embarked upon the development of a prototype web database for environmental data and analysis, which was given the name *MyClimateData*. Leon Zak, president of Zak Software Inc. of Rochester New York, USA was the lead developer for the web prototype. In this prototype, analysis of the temperature and RH data was done off-line using Climate Notebook®. Environmental metrics and summary statistics were calculated, graphs produced, and then moved to the web. Plans for future versions of the web tool call for all data storage and analysis to be accomplished on the web server without the need for off-line use of CNB.

DESIGN ISSUES FOR WEB DATABASE OF COLLECTION STORAGE INFORMATION

The database design used in the NMD project is extensible, meaning that any type of textual or numerical information can be added as the need arises. This was accomplished by having a database structure of only four distinct fields, with the name of the location (which defines where the environmental data was gathered from) as the unique identifier and organizing principle. The other three fields were 'ID #', 'kind', and 'data'. Each record in the database was tied to a particular value of the 'location' field. The ability to extend the database by adding a new type of information—for example, "emergency contact number"—was enabled by saving "emergency contact number" in the 'kind' field and the telephone number itself in the 'data' field. To the user, it appears as if there are many fields to the database, while in reality only four exist. This database design avoids the problem of having to pre-determine the field structure. In the NMD project, about 40 different kinds of information were stored in the database. These were organized into five categories for presentation to the user: Location Information, Collection Information, Mechanical System Information, Logger Information, and Administrative Information.

ORGANIZATION AND PRESENTATION OF ENVIRONMENTAL DATA ON THE WEB

During the NMD project the web interface evolved considerably, ultimately including navigation tools and search functions where analysis could be organized based on location or on any type of information contained in the database. The interface

also included summaries of environmental risks, presentations of mismatches between collection materials and their storage environments, a search function whereby locations suitable for storage of specific materials could be identified, comparisons among spaces, and screens for displaying and editing information contained in the database of locations. In addition, the interface also contains the ability to call up photographs of storage locations, maps and floor plans marked with icons showing loggers, water leaks, etc. There is also a separate database of collection component materials (iron, wood, etc.). This database is also extensible and allows the user to set her own limits for environmental risks, as defined by a particular institution for its collections. User

access to the web site is via username and password, administered by a superuser. The web site is protected by a Secure Socket Layer (SSL) certificate.

One of the most interesting challenges for the website design was the problem of navigation, i.e., selection of single or multiple locations grouped for analysis. The most common way users want to view data is by physical location. The solution chosen as a default navigation interface was a 'directory tree' similar to the one found in MS Windows Explorer®, in which users can click on tree levels to expand or collapse them to greater or lesser levels of detail. This tree view is based on certain fields in the location database. When adding a location, it is mandatory to enter values in these fields to enable the geographical navigation using the tree. For each location, a hierarchy consisting of institution, site (group of buildings), building, floor, room and location must be entered. By default, only the site and building level are shown. When the user clicks on any part of the tree, they are presented with an environmental risk summary on the right hand side of the screen. This summary shows all the locations in the hierarchy contained in or below the tree level that the user clicked. In this way, the user can review a group of geographically related locations, for example, all of the locations in a single building, or all of the locations in on one floor. It is also possible to select a group of locations based on any criteria stored in the location database using a 'search by' function (example: show all locations with objects belonging to the Modern Danish History Department) or 'search for' function (example: show all locations containing objects made from skin or fur). Reports joining multiple locations can be generated using a separate comparison function.

ENVIRONMENTAL RISK SUMMARY

After selection of one or more locations, the user is presented with a screen that summarizes the general environmental characteristics of the location. This is in the form of a color-coded environmental risk summary. This shows the list of locations and four columns labeled "Natural Aging", "Mechanical Damage", "Mould Growth" and "metal Corrosion". Each of these columns can contain values of "Good" (colored green), "OK" (colored Gray) and "Risk" (colored red). These words and color codes are based on the environmental metrics calculated from temperature and RH data and listed in Table 1. They are a simplification based on either defined levels of a single metric (TWPI in the case of Natural Aging) or a combination of them.

Also shown in the Environmental Risk Summary is the time period used in the calculation of the metrics. The analyst always needs to know what span of time his or her analysis deals with. The IPI metrics are most informative when calculated for a years' span of time because usually the most important sources of environmental variation are seasonal. Integrating the analysis over a 12-month span gives a more accurate impression of the conditions and allows for easy comparison of one year with another. In the NMD project, the *MyClimateData* web prototype used pre-defined one-year time periods. For each location, the analyst could review graphs and metrics for each year in which data had been collected, as well as choose an integrated analysis of all the data over the entire logging period. By default, analysis of the most recent 12 months was shown.

The purpose of the Environmental Risk Summary is twofold. It is meant to be a quick presentation of the general preservation quality of the environment measured in each location. It allows the analyst to process lots of information at a glance and to report it in a simple, easy to understand way to non-specialists. The second purpose for the Environmental Risk Summary is to be an interface for detailed analysis of individual locations shown in the summary. Clicking on a location name brings up an individual location summary, where the analyst can choose from a number of different types of information, from graphs to photos, floor plans, and so on.

CONCLUSION

The NMD project is now in its final analysis phases. The metrics and risk summaries have made it possible to identify and rank various environmental risks to NMD collections, and the web database has made accessible a variety of useful collections management information.

AUTHORS

James M. Reilly
Director, Image Permanence Institute
Rochester Institute of Technology
70 Lomb Memorial Drive
Rochester, NY 14623-5604
USA
jmrpph@rit.edu

Jesper Stub Johnsen
Director of Conservation
The National Museum of Denmark
Department of Conservation
IC Modewegsvej, Brede,
DK-2800 Kgs. Lyngby
jesper.stub.johnsen@natmus.dk

Lars Aasbjerg Jensen
Conservation Scientist
The National Museum of Denmark
Department of Conservation
IC Modewegsvej, Brede,
DK-2800 Kgs. Lyngby
Lars.Aasbjerg.Jensen@natmus.dk

REFERENCES

- 1 Ashley-Smith, Jonathan, *Risk Assessment for Object Conservation*, Oxford, UK, Butterworths, 1999
- 2 De Bruin, Gerrit, *An Assessment of DeltaPlan: The Dutch National Preservation Strategy*, *Liber Quarterly* 14:356-367
- 3 Plenderleith, H.J., *The Conservation of Antiquities and Works of Art*, Oxford University Press, 1955, pp. 1-15
- 4 Appelbaum, Barbara, *Comments from a Conservator on Climate Control*, *WAAC Newsletter*, Volume 18, No.3 September, 1996
- 5 Hancock, Martin, *The OCEAN Project at the V & A*, *V & A Conservation Journal*, No. 46, Spring 2004, pp. 20-22
- 6 Erhardt, D. and Mecklenburg, M., *Relative Humidity Re-Examined*, Preprints to the Ottawa Congress, 12-16 September 1994, London: International Institute for the Conservation of Historic and Artistic Works, 1994 pp. 32-38
- 7 Sebera, D.K., *A Graphical Representation of the Relationship of Environmental Conditions to the Permanence of Hygroscopic Materials and Composites*, Proceedings of Conservation in Archives International Symposium, Ottawa, Canada, May 10-12, 1988, Paris: International Council of Archives, 1989, pp. 51-76
- 8 Michalski, S., *Relative Humidity in Museums, Galleries, and Archives: Specification and Control*, in *Bugs, Mould, and Rot II: Workshop Proceedings of Moisture Control Workshop*, W. Ross and Anton Ten Wolde, eds., Washington: National Institute of Building Sciences, 1993, pp. 51-62
- 9 Reilly, J. M., Nishimura, D.W., and Zinn, E., *New Tools for Preservation: Assessing Long-Term Environmental Effects on Library and Archives Collections*, (Washington, DC: The Commission on Preservation and Access, 1995)
- 10 Reilly, J. *IPI's Climate Notebook® Software for Environmental Analysis*, Proceedings of the Conference Archiving April 26-29 2005, Washington: Society for Imaging Science and Technology, 2005, pp 67-72
- 11 Image Permanence Institute Staff, *Step-by-Step Workbook: Achieving a Preservation Environment for Collections*, published by Image Permanence Institute, Rochester Institute of Technology, 2005 (available as web publication from www.imagepermanenceinstitute.org)



This work is licensed under a Creative Commons Attribution - Noncommercial - No Derivative Works 3.0 Licence.

TARGET MICROCLIMATE FOR PRESERVATION DERIVED FROM PAST INDOOR CONDITIONS

ŁUKASZ BRATASZ, DARIO CAMUFFO AND ROMAN KOZŁOWSKI

ABSTRACT

A novel approach is proposed to establishing target indoor microclimates suitable for the preservation of organic materials susceptible to fracture and deformation, such as wood and paints. It assumes that it is impossible to establish a priori the best RH level for the conservation of mixed collections containing organic materials as over many decades they have adapted to a particular indoor environment within which they have been preserved. Therefore, the proposed strategy focuses on replicating the past average levels of RH and specifies bands of tolerable short-term fluctuations superimposed on these average levels. It is proposed to cut off 16 % of the largest, most risky fluctuations, which corresponds to one standard deviation in the distribution of the fluctuation amplitudes. Further, it is proposed to reduce the width of the target band of tolerable fluctuations by taking into account how much the fluctuations depart from the average seasonal RH level. The procedure is illustrated by three case studies of historic churches representative of different geographical locations, construction materials and patterns of use.

INTRODUCTION

A novel approach is proposed to establishing target indoor microclimates for organic materials susceptible to fracture and deformation, such as wood and paints. Both temperature (T) and relative humidity (RH) are key control variables to ensure their proper conservation. For the sake of brevity, the discussion in this paper is limited to RH, but the approach would be the same for T. Changes in RH induce changes in the equilibrium moisture content (EMC) as the organic materials absorb and release moisture to adapt to the continually changing environmental conditions. The variations in EMC produce dimensional changes which may lead to high levels of stress and mechanical damage. Furthermore, too high or too low RH levels represent rapidly growing risks of various types, such as biological attack, rapid corrosion or low humidity desiccation and fracture of fragile materials.

The conventional museum practice is to recommend a continuous control of RH to as constant a level as possible. The optimum RH set-point is usually specified within the 50-60% range. The National Trust Specifications for Conservation Climate Control [1] are a well known example. An alternative approach presented in this study assumes that it is impossible to establish a priori the best RH level for the conservation of mixed collections of organic moisture-absorbing materials, as over many decades they have adapted to a particular indoor environment within which they have been preserved. Such adaptation might have involved a certain degree of permanent change, as deformation or fracturing, releasing internal tensions in the materials generated by the variations of RH. A compression set of wood, demonstrated by Mecklenburg et al. [2] is a case in point. Such capacity of the organic materials to adapt can be termed a memory of the past microclimate. If this particular past microclimate is suddenly changed, a climatic shock can occur leading to damage, even though the new conditions may be considered better for preservation.

Therefore the proposed strategy focuses on specifying optimum target microclimates which would replicate the past average level of RH if this proved not harmful in terms of mould growth, for the high humidity region, or desiccation and mechanical failure for dry environments. Further, the target band of tolerable RH fluctuations will be specified. Specifying tolerable RH fluctuations is important, as gradual small changes in the museum objects lead to damage at the micro level – a fatigue of historic materials - well before any visual damage appears. Such continuous accumulation of slight changes, rather than infrequent serious damaging events, accounts for much of the deterioration processes observed in museums. Eliminating fluctuations exceeding some critical amplitude would restrict the fatigue.

Given the individual differences between microclimates, which depend on the characteristics of buildings and the specific climate outdoors, target indoor microclimates based on past conditions have been so far recommended in general and descriptive terms. The Italian Standard UNI [3] on

indoor environments, which stresses the need to replicate the long-term local climate and to keep the T and RH variations to a minimum, has been a good case in point. This study is proposing analysis of the past indoor T and RH data to predict the target microclimate in terms of average values and fluctuation band. The past microclimatic data for a building or a room should be available for a period of at least one year. The proposed analysis can be universally applied both to natural microclimates in buildings with no heating or forced ventilation and to artificial microclimates in buildings where, for instance, heating systems have been operated.

RESULTS

The procedure is illustrated by three case studies of historic churches.

CASE STUDY I

The wooden church of Saint Michael Archangel, Dębno, Poland. This building is unheated – a relatively open structure with an indoor climate strongly governed by the outdoor weather due to a high rate of air exchange between inside and outside

Figure 1 shows plots of indoor RH for the Dębno church. The RH data (the jagged blue line) were sampled every fifteen minutes for one year, beginning in June and ending in May the subsequent year. The sampled data were smoothed by calculating the running average in the two adjacent one month periods (red line) to obtain the seasonal variability. The yearly average is 71%. An increase in winter up to 80% and a decrease in warm period down to 55% are observed.

The seasonal variability is quite considerable when it is compared with the museum standards for indoor climate stability, exemplified in this paper by the National Trust (NT) specifications. The upward deviation observed exceeds the allowable increase by 7%, specified as the first alarm level by NT. Moreover, in absolute terms, the maximum seasonal deviation of RH in the church attains the upper limit of 80% above which attention should be paid to the risk of mould growth. The downward deviations during the spells of dry weather in spring or summer come close to the decrease by 18%, specified as the second alarm level by NT.

The short-term RH fluctuations, superimposed on the seasonal variations, are shown in Figure 2. They were extracted from the raw RH data by subtracting

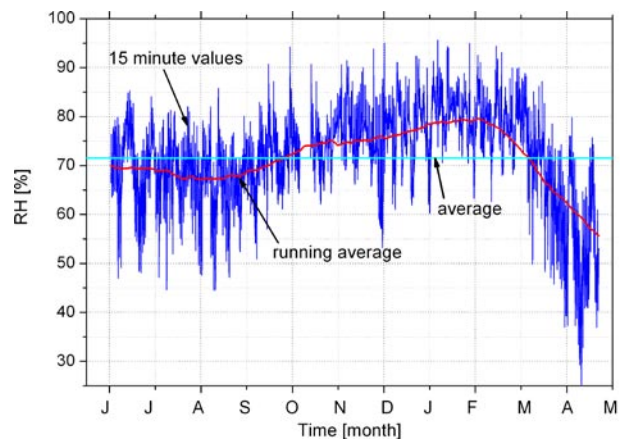

Figure 1. Dębno wooden church. Indoor RH during one year measured at fifteen minute intervals (the jagged blue line) and a general seasonal RH tendency (smooth red line) obtained by calculating the two-month running average of the readings. The yearly average is marked by a horizontal line.

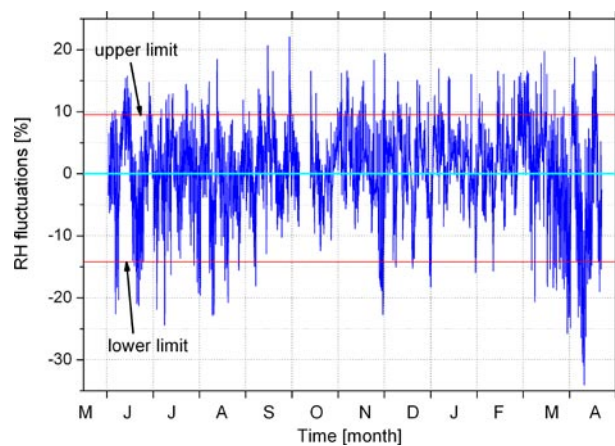

Figure 2. Dębno wooden church. The short-term variations of RH around the general seasonal tendency.

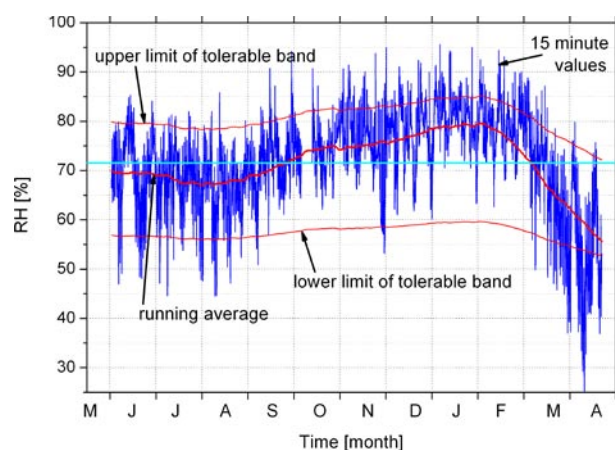

Figure 3. Dębno wooden church - target band of tolerable fluctuations (marked by two red lines) compared to the observed variation in RH.

the running average from the instantaneous RH (blue line minus red line in Figure 1). The lower and upper limits of the tolerable band, marked as red lines, correspond to the 8th and the 92nd percentiles

of the fluctuations, respectively. This means that 16 % of the largest, most risky fluctuations are cut off, which corresponds to one standard deviation in the distribution of the fluctuation amplitudes. As a result, the target band is based on the 84% of fluctuations recorded in the past. The choice of the target band width is arbitrary, but it corresponds to a common statistical reference.

The analysis of the data can be further refined by assuming that not only the amplitude of each fluctuation is significant, but also a particular average RH value on which the fluctuation is centred. A fluctuation centred around the yearly average, in this example 71%, may be assumed less damaging than the same fluctuation centred around a much lower (summer period) or higher (winter period) seasonal RH. In reality, the actual risk is due to the combined effect of the fluctuation and the seasonal RH level at the moment of the fluctuation. To account for the actual risk the fluctuations can lead to, the target band should be reduced when the conditions depart from the yearly average. In this procedure, the maximum allowable seasonal departure from the yearly average RH was assumed to be 20% upwards and downwards, following approximately the second alarm levels recommended by NT. Accordingly, the width of the RH fluctuation band was reduced by a weighting factor that changed linearly between 1, when the seasonal value was equal to the yearly average, and 0 when the seasonal value departed from the yearly average by 20% or more. The final specifications of the target microclimate for the church are shown in Figure 3.

After having introduced this further correction, the target band of tolerable fluctuations calculated from the RH data has a changing, asymmetrical width around the running average. The band becomes narrower when the seasonal RH level comes close to the upper or lower risky levels of 80 and 55% respectively.

CASE STUDY 2

The Basilica S. Maria Maggiore, Rome. A large, unheated, brick church

Figure 4 shows plots of indoor RH recorded in the basilica. The yearly average is slightly above 60% without marked seasonality. The running average oscillates irregularly in a very narrow range from 55 to 65%.

The analysis of the short-term RH fluctuations, superimposed on the seasonal variations, is shown in Figures 5 and 6. The data processing was identical as for case study 1.

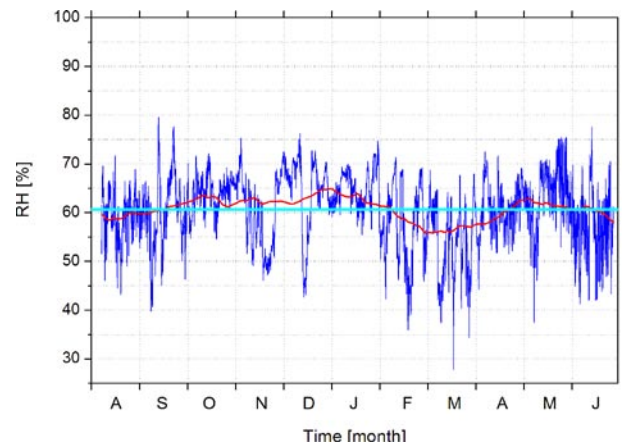

Figure 4. S. Maria Maggiore, Rome. Indoor RH during one year (blue line), with the average RH as described in figure 1.

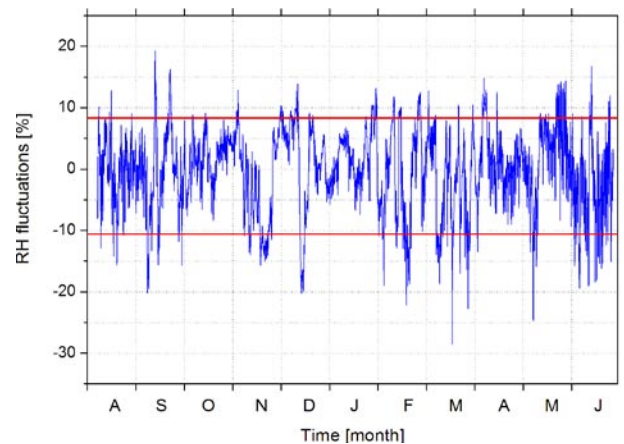

Figure 5. S. Maria Maggiore, Rome. Short-term variations of RH around the general seasonal tendency.

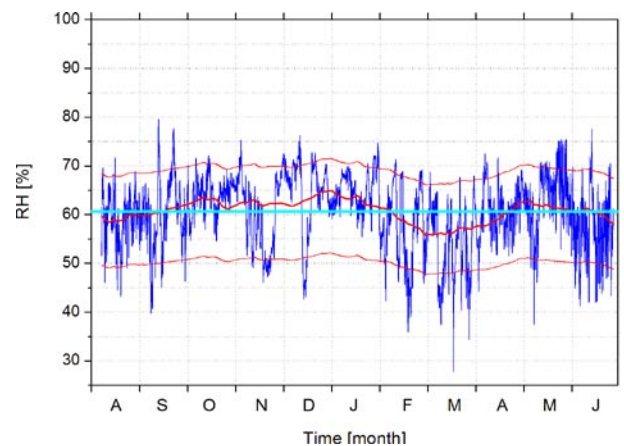

Figure 6. S. Maria Maggiore, Rome. Target band of tolerable fluctuations (marked by two red lines) compared to the RH variations observed.

CASE STUDY 3

The stone church of Santa Maria Maddalena, Rocca Pietore, Italian Alps. In winter, intermittent warm-air heating for liturgical services.

Figure 7 shows a plot of RH in the Rocca Pietore stone church. The yearly average RH is 55%. The long-term RH variability shows a clear seasonal character. The average RH decreases by approximately 10% into the range between 40-50% in winter in contrast to 60-70% during the warm period. The heating episodes are visible as deep drops in the RH record. It should be noted that the seasonal RH cycle shows an opposite tendency when compared to the wooden unheated church in Dębno (case study 1). The decrease of the general RH level in winter is caused by heating.

The seasonal variability illustrated by the smoothed red line of Figure 9 can be compared again with the National Trust specifications. Both the upward and downward deviations from the yearly average of 55% only slightly exceed the 7% change considered as the first alarm level by NT. Moreover, the seasonal upward RH variation remains well below the upper limit of 80% above which the risk of mould growth appears.

The short-term fluctuations, superimposed on the seasonal variations, are shown in Figure 8. The lower and upper cut-off levels, the 8th and 92nd percentile respectively, are shown as red lines. They were calculated from climatic data of the warm periods only, during which the indoor climate can be considered natural, not disturbed by the heating episodes. The target band reduced by a weight factor, as in the previous case studies, is compared with the observed RH variations in Figure 9. It is obvious that the major problem to the climate stability in the church is the heating system operated sporadically, which generates short-term RH drops hugely exceeding the lower limit of the target band of tolerable RH variations derived from the natural climate of the church. Improvement in the heating system is the principal measure necessary to stabilise the climatic conditions.

The analysis of the past microclimates in the three churches studied is summarised in Figure 10. It places the target bands of tolerable RH fluctuations for the three historic churches on the scale of the average seasonal RH level from which the fluctuation starts. It can be noticed that the band width for the two Italian churches, which are relatively enclosed brick and stone structures, are similar and smaller than the band width for the wooden church, a relatively open structure more susceptible to the outdoor climatic variations. It is also obvious that the domain of tolerable RH fluctuations for the Dębno church is considerably shifted to a high RH region,

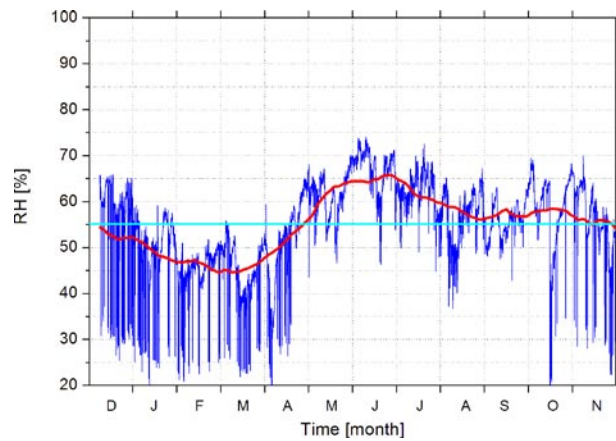

Figure 7. Rocca Pietore church. Indoor RH during one year , with average RH as explained in figure 1.

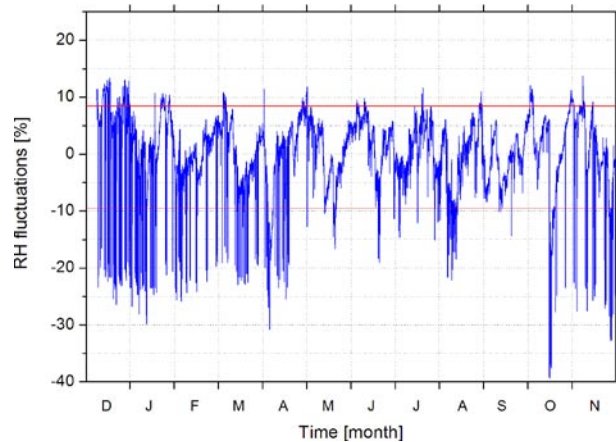

Figure 8. Rocca Pietore church. Short-term variations of RH around the general seasonal tendency.

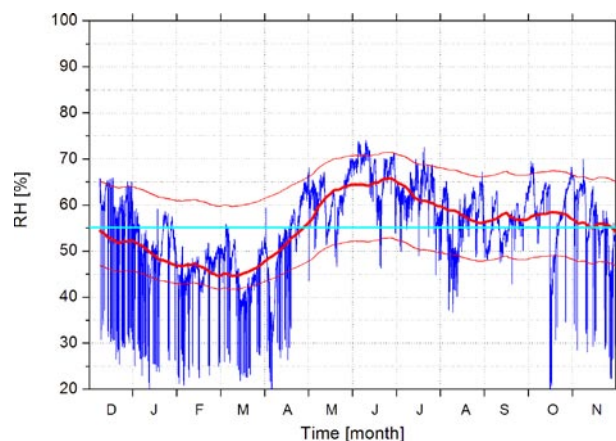

Figure 9. Rocca Pietore church. Target band of tolerable fluctuations (marked by two red lines) compared to the RH variations observed.

due to the much more humid climate prevailing in northern Europe. In turn, the domain of tolerable RH fluctuations for the Rocca Pietore church is extended to a low RH region, which is a direct result

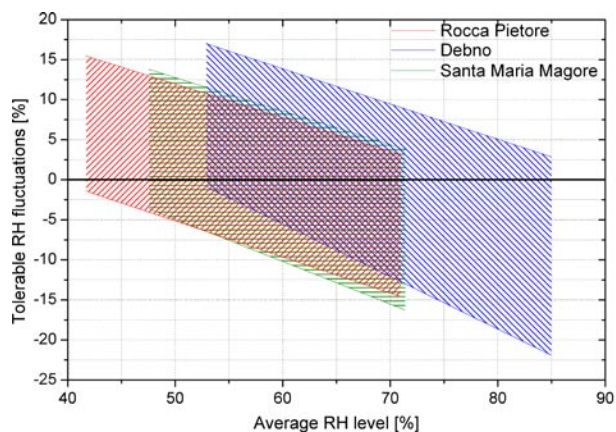

Figure 10. Tolerable RH fluctuations in the three historic churches as a function of the average seasonal RH level.

of low RH in the winter period in the past, due to the excessive heating.

The scheme in Figure 10 provides a practical example of the specifications for the tolerable RH fluctuations based on the knowledge of the historic climate of a specific object in its environmental context, measured for one year. The specifications have been derived from the past short-, mid- and long-term RH variability in the building, which is due to daily fluctuations, weekly weather changeability and yearly average level. They might provide a useful tool for preventive conservation, helping for instance to formulate the climatic specifications in loan agreements, the design specifications for low-level heating in winter or a regulation system for exchanging the indoor air when the outside conditions are favourable.

CONCLUSIONS

The three case studies of historic churches representative of different geographical locations, construction materials and patterns of use (unheated and heated) have provided examples of how past indoor conditions can provide useful information on the tolerable fluctuations in RH to which organic materials susceptible to fracture and deformation have acclimatised. The lower and upper limits of the target band of the tolerable fluctuations have been arbitrarily established as the 8th and 92th percentiles. This means that 16 % of the largest, most risky fluctuations are cut off, which corresponds to one standard deviation in the distribution of the fluctuation amplitudes. Although this is an arbitrary choice, the standard deviation is a useful, universally known statistical parameter, and can be proposed as a reasonable reference level in the recommendations. Further, the width of the target

band of the tolerable fluctuations has been reduced by taking into account how much the fluctuations depart from the average seasonal RH level.

A similar approach of predicting the tolerable RH variability from the historic microclimate has been recently proposed by Michalski [4]. He has introduced the concept of ‘proofed RH or T’ which is the largest RH or T fluctuation to which the object has been exposed in the past. It is assumed that if the future climate conditions do not exceed the proofed values, the risk of mechanical damage beyond that already accumulated is extremely low. In particular, if the past fluctuation caused fracture of the object, the stress generated by the new fluctuations is released and the object will not undergo further damage. The approach proposed in this paper is based on a slightly different assumption that mechanical damage can be cumulative rather than catastrophic, therefore larger fluctuations, even if not exceeding the historic levels, can involve risk of damage. The risk is larger when the seasonal RH values depart from the yearly average. This has been taken into consideration by correspondingly reducing the tolerable levels of the fluctuations.

AUTHORS

Łukasz Bratasz
Institute of Catalysis and Surface Chemistry, Polish Academy of Sciences
ul. Niezapominajek 8, 30-239 Kraków, Poland.
ncbratas@cyf-kr.edu.pl

Roman Kozłowski
Institute of Catalysis and Surface Chemistry, Polish Academy of Sciences
nckozlow@cyf-kr.edu.pl

Dario Camuffo
Institute of Atmospheric Sciences and Climate, National Research Council of Italy (ISAC-CNR)
Corso Stati Uniti 4, I-35127 Padova, Italy.
d.camuffo@isac.cnr.it

REFERENCES

- 1 Staniforth, S., Hayes, B., and Bullock, L., ‘Appropriate technologies for relative humidity control for museum collections housed in historic buildings’ in *Preventive Conservation Practice, Theory and Research*, International Institute for Conservation of Historic and Artistic Works, London (1994) 123-128.

- 2 Mecklenburg, M.F., Tumosa, C.S., and Erhardt, D., 'Structural response of painted wood surfaces to changes in ambient relative humidity' in *Painted Wood: History and Conservation*, The Getty Conservation Institute, Los Angeles (1998) 464-483.
- 3 Italian Standard UNI 10969, *Cultural Heritage - Environmental conditions for conservation. General principles for the choice and the control of the indoor environmental parameters. Part 1 Microclimate* (2002).
- 4 Michalski, S., 'The ideal climate, risk management, the ASHRAE chapter, proofed fluctuations, and towards a full risk analysis model' in *Experts Roundtable on Sustainable Climate Management Strategies*, The Getty Conservation Institute (2007) *in press*.



This work is licensed under a Creative Commons Attribution - Noncommercial - No Derivative Works 3.0 Licence.

DUST IN HISTORIC LIBRARIES

HELEN LLOYD, CAROLINE BENDIX, PETER BRIMBLECOMBE AND DAVID THICKETT

ABSTRACT

Dust poses a particular challenge for historic libraries, where the quantity of fragile books makes the task of cleaning them labour-intensive, time-consuming and potentially damaging. This project investigates the frequency of cleaning appropriate in historic libraries, by monitoring the distribution of dust across shelves, the risks of high humidity causing cementation, and the usefulness of traditional dust falls (cloth or leather flap covering the gap between book and shelf above). The results enable book-cleaning teams and their managers to understand the relationship between visitors, dust and cementation, and to refine their cleaning regimes.

INTRODUCTION

Dust is recognised as a widespread problem for historic interiors, its presence reducing artistic value and imposing considerable cost in cleaning. Within properties belonging to the National Trust, English Heritage and Historic Royal Palaces, control and removal of dust represents one of the largest calls on budgets for housekeeping and preventive conservation [1]. Having said this, dust can also add a sense of mystery or historicity to interiors and in itself can provide evidence of the past or perhaps even be considered to add patina. Some historic properties are deliberately presented today with an air of dustiness to reflect the lack of housekeeping prevalent when the rooms were formerly occupied [2].

Libraries are a particular challenge because of the very large numbers of books that can be housed within a single room (Fig. 1). Cleaning books is labour intensive and time consuming, requiring the use of brushes and, on occasion, vacuum cleaners with variable suction [3]. In modern libraries this has prompted the development of commercial devices to clean books, such as the De Pulvera and Bassaire machines [4]. While there have been some worries that dust on books represents a health threat to librarians and readers, and more widely to staff and visitors in historic properties, dust is more likely to be a really serious issue during cleaning. Dust often contains mould spores, especially if the books have not been cleaned for some time and are in an uncontrolled environment. Evidence suggests that mould spores have the potential to damage the human immune system, so when cleaning and

handling mouldy material, it is always sensible to wear appropriate protective clothing. [5, 6]

Books are made from organic materials, and many books in historic libraries are now fragile, their materials degrading and fragmenting, and creating dust. At the same time, books are potentially damaged by dust, by handling and by the abrasive process of repetitive cleaning. As books in historic houses are rarely read, cleaning activities are usually the major source of mechanical damage.

The design of some books makes them more vulnerable to damage during cleaning. Publisher's bindings generally have uncut text-block edges which become stained and brittle after prolonged exposure to dust. To clean them is time-consuming and difficult, as every page must be treated individually. In albums stored vertically on shelves, where the pages cannot close firmly together, there is greater potential for dust and humidity cycles to penetrate down into the gaps between the pages resulting in 'foxing' or staining of the paper, which remains after any dust has been removed.

In historic houses, teams of volunteers have been trained by a libraries conservator to clean books. The work has been carried out annually by rote, with little understanding of the variations in dust deposition in different parts of a room. This resulted in unnecessary handling and abrasion to books, and a lack of attention



Figure 1. View of the Library at Felbrigg Hall in Norfolk (UK), taken from the visitor route in the south-east corner. The Gothic interior was commissioned by William Windham II in 1752-5 and houses the books collected on his Grand Tour of Europe. ©National Trust Photographic Library/Nadia Mackenzie



Figure 2. Close-up showing five of twelve sticky samplers attached to slide mounts and inserted in a bearer strip on a library bookshelf. Every three months one dusty sampler was removed and stored in a rigid case until the end of the three-year monitoring project.

to the needs of individual volumes, whether more fragile or less dirty. However, once trained, and in the absence of hard evidence to support the need for a different approach, book teams have proved reluctant to refine their practices or swap their coarse hogs-bristle shaving brushes for softer pony-hair brushes.

In this project we have investigated the frequency of cleaning appropriate in historic libraries by monitoring the distribution of dust across shelves and presses, the risks of high humidity and the usefulness of traditional dust falls. This work enables book-cleaning teams to understand the relationship between visitors, dust and cementation.

MONITORING DUST IN LIBRARIES

We have now gathered a considerable amount of data concerning the deposition of dust in historic interiors generally [7], and further information about libraries in particular [8]. In parallel, automated monitors were used to aid assessment of the source and rate of dust accumulation in historic interiors [9].

Our measurements have used either glass slides with image analysis [10] or sticky samplers and, for libraries, we developed simple monitoring kits of bearer strips, each carrying twelve sticky samplers, which were laid on top of books (Fig. 2). Every three months, one sampler was removed from the strip and stored until the end of the project for comparison with samplers removed at different quarterly intervals. This method allowed the continuation of sampling over periods up to three years and also created the opportunity to compare several locations in different parts of the country. Within individual libraries, the samplers were located according to a variety of

criteria, such as proximity to the visitor route, height from the ground, and headroom between book and shelf. We have also used sticky samplers for spot sampling and detailed analysis in libraries [11].

Library interiors prove to be a heterogeneous environment, with areas of high and low dust deposition. Overall the measurements within libraries are much in line with our expectations from other historic interiors accessible to visitors [7]. They emphasise the role of the visitor in delivering coarse dust to the surfaces of materials that are on open display, yet libraries are protected from the usual sources of outdoor particulate material because they are in relatively well sealed rooms.

In archives, the source of dust is much reduced because there are few visitors and spaces are often air conditioned. Here the dust is predominantly degradation products from books (especially from leather red rot) and from documents or their storage boxes. There are other dust sources, of course, and, in some less well sealed old libraries in London, the books are still black and smell of smoke from coal fires, deposited in earlier centuries, and other more recent airborne pollutants [12]. Pollutants from historic and modern industries and the combustion engine can affect books within urban libraries. However, potentially dangerous indoor emissions from traditional wood and coal fires affect not only urban interiors but also the libraries of historic houses in the countryside.

When examining books in historic libraries, it is not surprising to find that most of the dust is deposited on the top of text blocks. The elevation of the shelf above the floor is also significant; notice the large amount of dust at ground level and at 1.5 metres, and how this is affected by the distance between visitors and bookshelves (Fig. 4). The larger deposits between

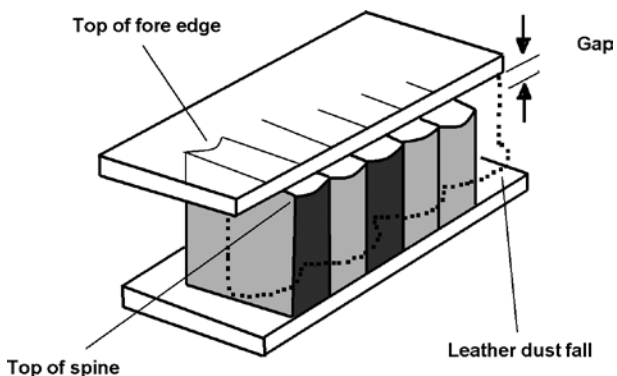

Figure 3. Terms used when describing the distribution of dust across books on shelves, and the effect of traditional dust falls (cloth or leather flaps covering the gap between the top of the book spines and the underside of the upper shelf).

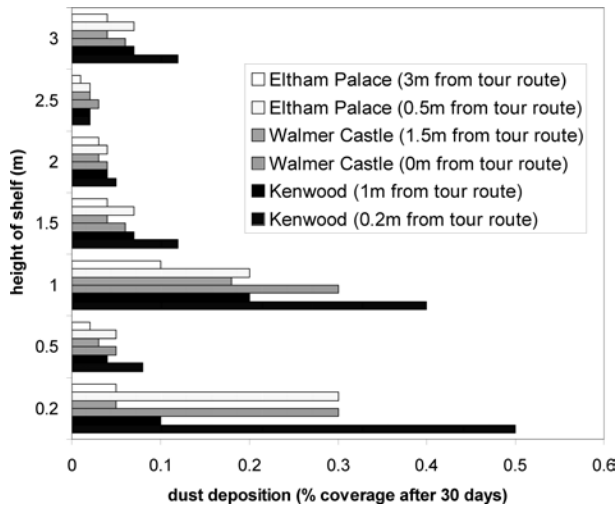

Figure 4. Rates of dust coverage close to floor level, and at shoulder height, are greater than on intermediate and higher bookshelves in historic libraries managed by English Heritage. Books closest to the visitor route receive more dust than those at a distance. Visitor proximity and activity generated similar patterns of dust distribution on state beds in the care of the National Trust and Historic Royal Palaces.

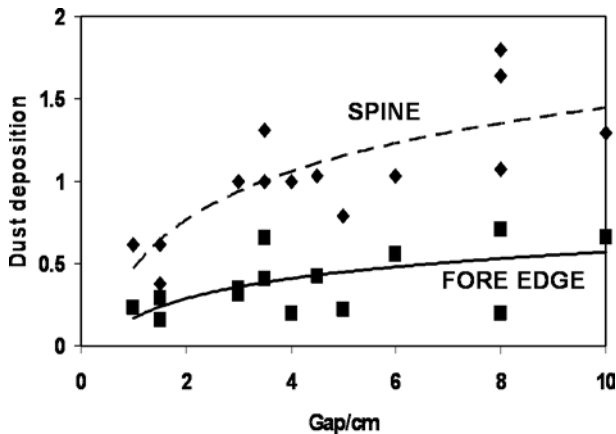

Figure 5. The rate of dust deposition at the fore-edge and spine of books is plotted against the size of the gap between the top of each book and the shelf above. Deposition rate is measured in Gs^{-1} [7] and generally rises as the gap size increases. The large scatter of data results from shelves at different heights above the floor and different distances from the visitor route. (Credit Y H Yoon)

1.0 - 1.5 m arise from dust and fibres shed from upper garments of visitors. The deposit close to the floor is somewhat coarser and arises from dust stirred up from the floor through walking. The gap between a book and the shelf above is another important factor; the bigger the gap, the greater the deposit – with more dust, quite naturally, being deposited at the spine compared with the fore-edge (Fig. 5).

Flaps to cover this gap, called dust falls, were sometimes installed in Victorian libraries and these substantially lower the rate of dust accumulation (Fig. 6, 7). However, their design means that in order to reduce dust deposition, the tops of the



Figure 6. Where traditional dust falls are installed in historic libraries, there may be a large reduction in dust deposition. However, where bookshelves are located against cold outer walls, there are also risks of increased humidity behind the books, with attendant propensity for mould growth.

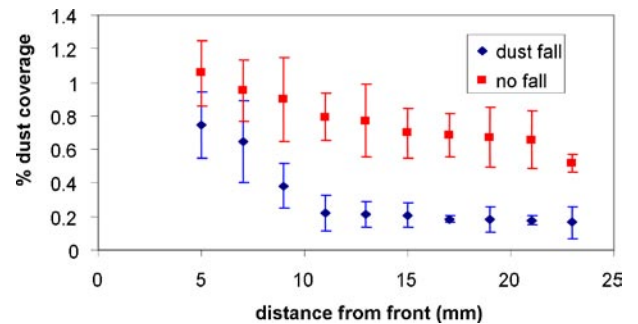

Figure 7. Fig Traditional dust falls reduce the penetration of dust, and rates of dust deposition, in bookshelves in the Great Library at Audley End House (English Heritage). The deposition rate is measured as % coverage over a thirty day period.



Figure 8. Damaged dust falls at Penrhyn Castle (National Trust), demonstrate the extent of cumulative abrasion that occurs between book spine and dust fall when books are removed from and returned to the shelves.

spines must be behind the falls. This can result in damage to the tops of spines, caused by abrasion against the falls whenever books are removed and replaced (Fig. 8).

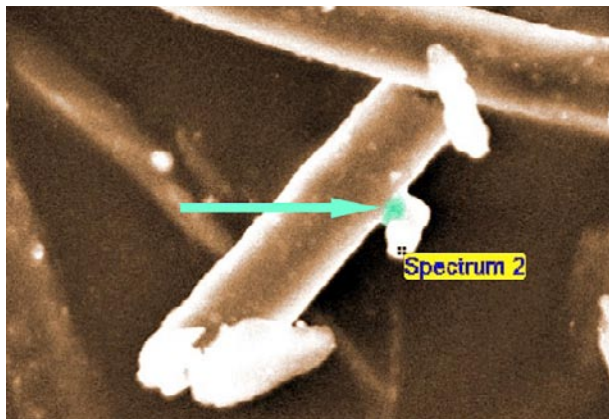

Figure 9. A Scanning Electron Microscopy image showing dust particulates cemented to textile fibres. The highlighted region binding the particle to the fibre is rich in calcium and, using Raman microspectrometry, has been identified as a fine grained calcite.

CEMENTATION

Where the dust just settles and can later be brushed off, it creates less concern than when deposits become ingrained or cemented to the underlying surfaces. In a recently completed three-year project funded by the Leverhulme Trust, we have been examining this process of cementation [13].

Cementation tends to occur at high humidity and can be driven by biological, physical and chemical processes. Under warm damp conditions (which are anyway harmful to paper) biological activity increases; bacterial cells can exude exo-polymers that can act like an adhesive and bind dust particles to the underlying substrate [14]. Humidity cycles cause physical movement of fibrous material that allow dust to embed deeper into porous surfaces [15, 16]. At high humidity calcium ions can leach from dust particles, and re-deposit as microcrystalline calcite, which cements the dust particle to the substrate (Fig 9) in much the same way as lime mortars recrystallise. This chemical process can be quite rapid at high relative humidity (80%) such that the cements may form in less than a day [15, 16].

The importance of humidity in the process of cementation has led us to examine the microclimate of bookshelves. Behind books, especially those on shelves against a cold outer wall, there is a potential for the formation of humid microclimates when warmer air moves in behind the books and cools, thus raising its relative humidity. At high humidity, dust adheres very effectively to organic materials such as cotton and silk [16] (Figs 10, 11). Books are largely made from organic materials, and their hygroscopic nature enables enhanced cementation.

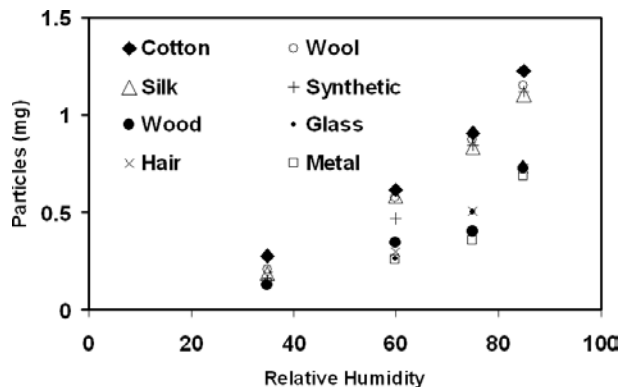

Figure 10. A variety of fibres (1 cm long) were exposed to fine soil dust in small dishes in the laboratory, at differing levels of relative humidity. After 4 weeks, greater quantities of dust had adhered to the fibres at 85% RH, than to those at 35% RH. The dust adhered more readily to textile fibres than to other materials.

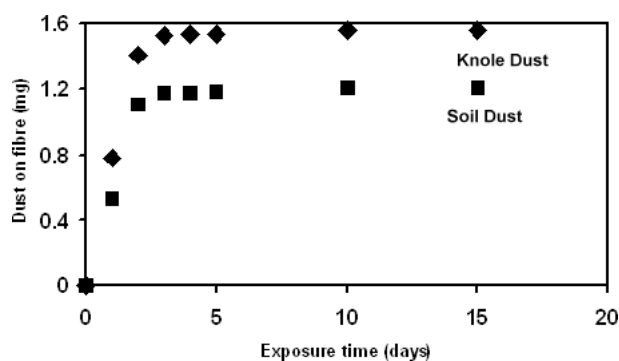

Figure 11. Two batches of cotton fibres were exposed, in a laboratory, to fine soil dust and to house dust extracted from vacuum cleaners at Knole in Kent (National Trust). In a matter of days, cementation of both types of dust had occurred but a greater weight of house dust adhered to the fibres because it is more hygroscopic than soil dust.

The cementation process increases dramatically at high RH values. Mould spore germination is also a strong function of relative humidity above 65%. Reducing ventilation across the gap between the tops of book spines and the shelf causes concern because of a number of mechanisms by which higher RH may be generated. Wet walls are common in historic buildings and ventilation is a major mechanism that reduces RH. As temperatures increase, the RH in equilibrium with the water content of the books will increase within a closed or low air exchange rate system. Rapid cooling of exterior walls can cause condensation leading to wet walls. At RH and temperatures supporting mould spore germination, air flow can significantly retard this process.

Two sets of library shelves were monitored at Audley End House, one on a damp external wall and the other on an internal wall. Similar runs of books were selected with two runs separated by a wooden divider and pieces of card fitted to one of each to act as falls. The test shelves were selected

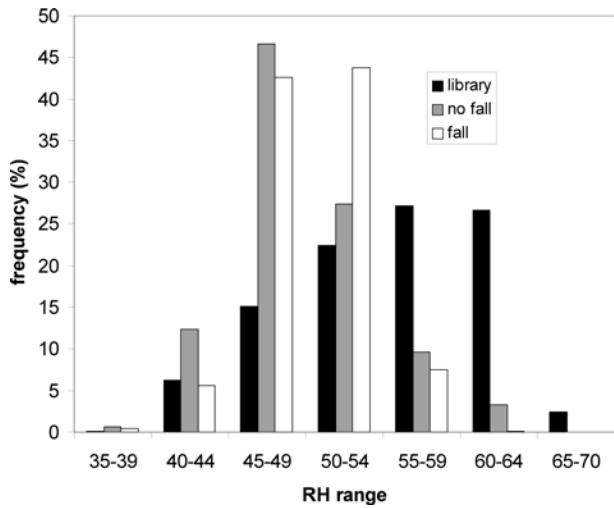

Figure 12. The environment in the Library at Audley End House, and behind books on shelves with and without dust falls. (A second set of measurements taken in front of the books gave identical results to those marked 'library' and has not been included.) The histograms show the time spent within specified RH intervals. Note the considerable stabilisation provided by the falls.

to provide as near to identical situations as possible. They had similar size books to give equal gap sizes and widths, similar dates and adjacent shelves. The conditions behind the books were monitored with electronic RH+T data-loggers for twelve months with the falls in position, and for a further six months after the falls were removed. The data-loggers were calibrated at three RH values with saturated salt solutions traceable to UK National Physics Laboratory standards.

Initial examination of the recorded data indicated little difference in relative humidity behind books, compared to the room environment. Figure 12 shows the results of monitoring and the frequency of various RH values (in intervals of 5% RH). One set of shelves with falls showed a greater degree of buffering (Fig. 13); the second set appeared to show less buffering than the adjacent set without falls. The extended six months monitoring without the falls in place revealed that these shelves had less stable RH behind them, probably caused by higher air exchange through the slatted wooden construction and hence the two sets of data were not comparable. The RH behind the false falls does not rise as high as that behind similar books when the temperature rises (Fig 13). This indicates that the buffering effect of the books is not the major driving factor in the RH rise. It would be expected to be greater behind the false falls as humidity escape would be expected to be limited.

In order to assess mass transfer the hourly vapour pressure change was calculated from the Clausius-Clapeyron equation. The data for the shelf with no falls is plotted against that with false falls in Fig 14. Since the slope of the regression line is less than one, more water vapour is moving into or out of the air behind the books with no falls, than when falls are present.

It would appear that in this instance ventilation is dominating the RH experienced behind the books. It is reassuring that addition of falls has not raised the RH in

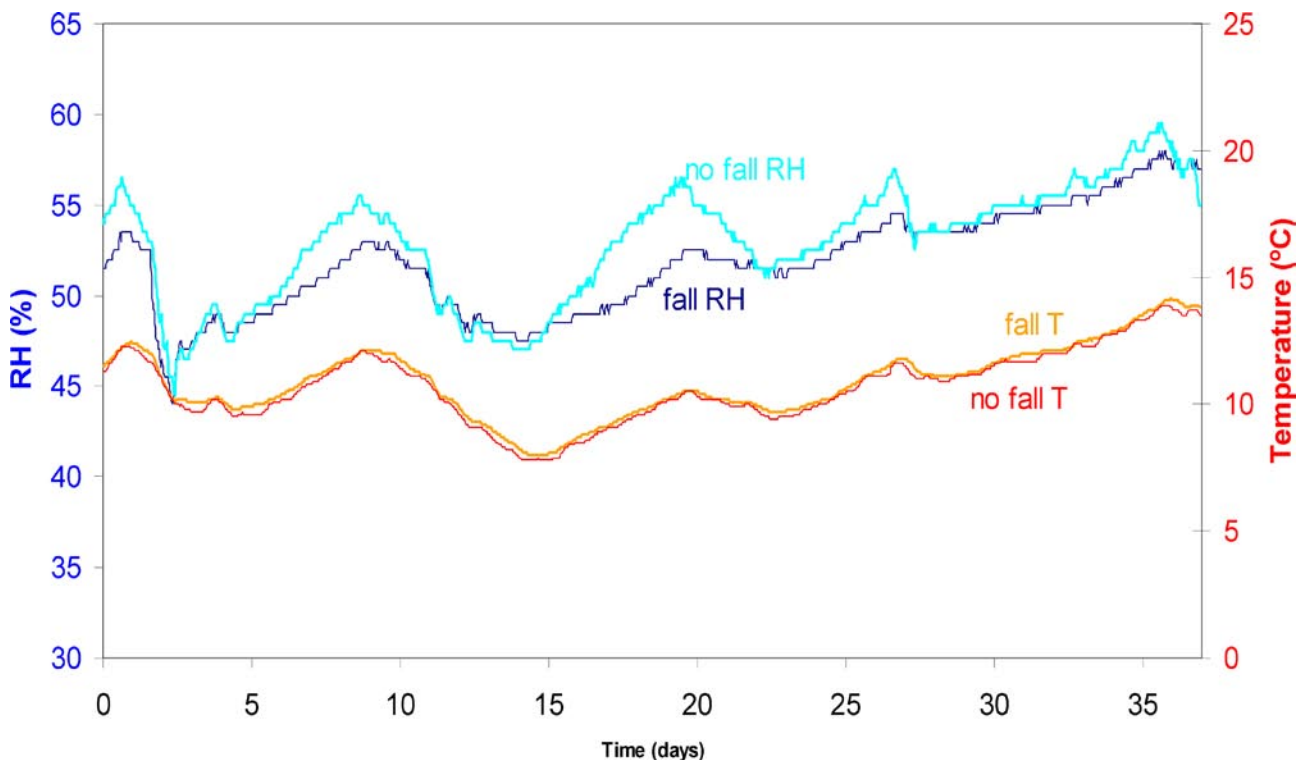

Figure 13. The environment behind books with dust falls compared to those without. Analysis detailed in the text indicated that the buffering effect of the books behind the falls was being overridden by ventilation.

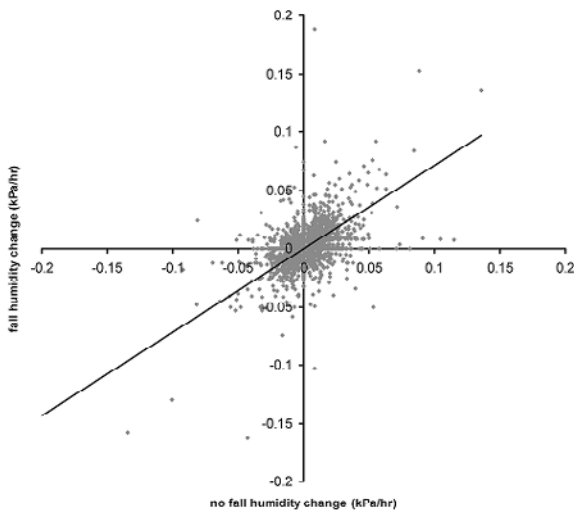

Figure 14. Rate of humidity change in KPa/hour with and without falls. The slope of the plot indicates whether water vapour transport is faster with or without the falls in place.

this case. These initial measurements have suggested that the air exchange is sufficient on most shelves to prevent enhanced cementation and mould growth from being a problem. However, monitoring would be required in each instance to ensure the risk is acceptable.

VISITOR AND STAFF PERCEPTIONS

Over recent years our research has examined visitor and staff responses to dust in historic interiors and libraries [17, 18]. In general, visitors have found the interiors clean and, although they appreciate that dust creates a sense of age, they are not especially forgiving if they sense care or cleaning standards have dropped [19]. A narrow group of staff meet visitors and sense their disquiet, so often feel obliged to press for more frequent cleaning [20].

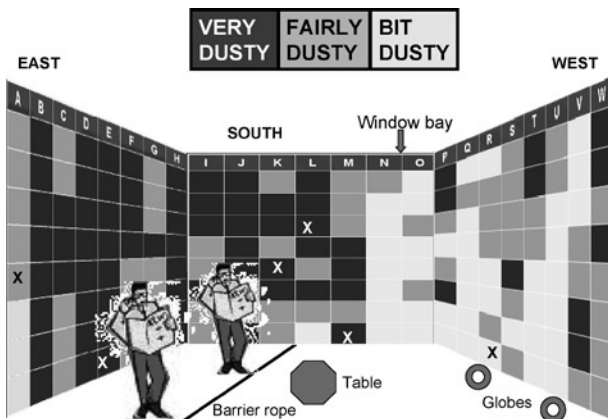

Figure 15. Mapping book shelves in the Library at Felbrigg Hall (Figure 1): the book team’s perceptions of dustiness are recorded on a schematic plan of the presses, together with the location of sticky samplers. On this occasion, the book team observed that no shelves were clean. The highest levels of dust were found beside the visitor route along the east and south walls.

Alison Walker, Head of the National Preservation Office has said that “libraries with historic collections are often perceived as dusty and old books are often described as dusty”. We studied the perceptions of volunteer book-cleaning teams who were asked to rate the shelves in book presses as “clean” “bit dirty” “fairly dirty” and “very dirty”.

The assessments by the book teams at Felbrigg Hall broadly matched more quantitative measurements using sticky samplers. The four shelves with the highest coverage of dust were also areas of shelving ranked dustiest by the book team. The shelf with the lowest measured coverage came from the area of shelving ranked as only ‘a bit dusty’ by the book team (Fig. 15). No shelves were termed ‘clean’. When shelves were labelled “fairly dirty”, this seemed to indicate that a historic library would soon need cleaning as staff began to worry about the appearance of the presses. Measurements from sticky samplers suggested that this occurred when more than 6-7% of the surface was covered by dust (Fig. 16).

In some of the libraries we examined, it could often take more than three years before this amount of dust would accumulate. The rate of deposition in libraries is less than half that encountered on other furnishings on open display in historic interiors, where housekeepers are prompted to clean when only 2-3 % of surfaces are covered by dust. It is perhaps not surprising that books can be left longer before needing cleaning, as books on shelves are less exposed to dust, and partially hidden from view.

Judging dustiness by eye is a subjective process and one person’s definition may well differ from another; this means that staff working in historic libraries need help in making objective assessments of when the level of

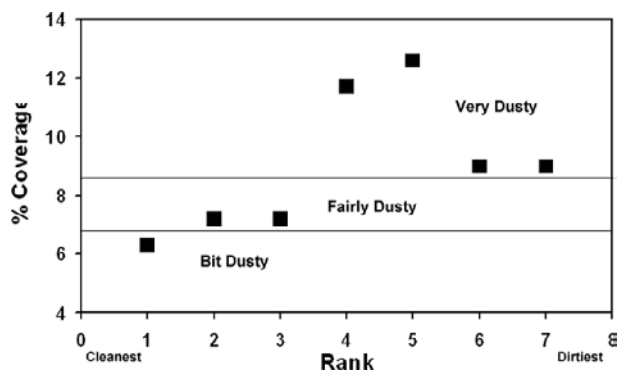

Figure 16. Perceptions of dustiness at Felbrigg Hall broadly match more quantitative measurements using sticky samplers. The four shelves with the highest coverage of dust were in areas ranked dustiest by the book team. The lowest measurement coincided with the book team’s ranking of ‘a bit dusty’. Where more than 6-7% of the surface was covered by dust, shelves were labelled “fairly dirty”, and deemed to be in need of cleaning.

dust is sufficient to demand cleaning. Semi-objective measurements can be made by wiping a defined area of the top edge of the boards and text-block, or the shelf, and retaining the sample pads for comparison with that taken from other books. While books with gilt-edge decoration lend themselves to this approach, those with deckled edges give less clear results. A semi-quantitative tool currently under development is a simple monitoring kit using sticky samplers, a hand lens and a calibration scale to indicate percentage coverage. Prototype dust monitors that allow computer analysis of images of dust deposition recorded in real time have been used for a number of studies [9].

MANAGEMENT OF DUST

Practical outcomes from this study can be incorporated into preventive conservation regimes for the care of historic libraries. Control of relative humidity is key because, where it is impossible to predict excursions outside the normal target band (50-65% RH in National Trust properties [21]), books will need to be cleaned more frequently than once in three years to prevent cementation of any substantial deposits of dust. Fortunately in most libraries, the shelves are close enough together for this not to be a significant issue, but where books are exposed to deposits of dust, the optimum time for cleaning might be the end of dry spells. This extra cleaning conflicts with the desire to reduce the frequency of handling, which accelerates degradation of materials and generates dusts.

Rates of dust deposition can be reduced in libraries, as elsewhere in historic houses, by keeping visitors away from shelves and presses, using rope barriers to achieve 1.5-2 m distance between visitors and books. Such separation is likely to reduce the deposition of dust two- to four-fold. Where space is tight, transparent barriers to shoulder-height can also reduce deposition two-fold [7, 22]. Fewer visitors will reduce soiling, but if the flow of visitors increases dramatically, jostling may enhance the production of fibres from visitor clothing. Furthermore, overcrowding could force visitors to depart from the designated route and soil objects by greater proximity.

Limiting the hours of public access will release time for routine cleaning of robust surfaces, and occasional but timely treatment of fragile materials. Where possible, it is advantageous to remove accumulated dust before periods of high humidity and to protect surfaces with temporary covers during closed periods. Keeping windows and external doors closed helps to exclude dust. During activities such as events and building works, assess the risks and need for additional prevention and protective measures.

As cleaning can cause damage through abrasion (and is resource intensive), it can be delayed until dust has reached the identified critical levels at which aesthetic impact and public concern becomes significant. This may mean that, where there is little risk of high humidity occurring, library books are cleaned only every three years or more. However, any reduction in cleaning frequency must be accompanied by an annual check of books for mould and insect activity, to ensure the swift identification and treatment of any problems.

The design of the shelving should be considered, in particular the implications of dust falls. In our survey, we could find no effect of dust falls on humidity although, before taking decisions to use or reinstate dust falls, there may still be a need to monitor the internal climate of bookshelves where there are cold walls. The traditional design of dust falls attached to a fixed batten could be substantially improved if the batten were to be hinged. However, these interventive conservation measures may not be appropriate in historic libraries where dust falls were not originally installed.

Methods of preventing dust falling on books can be obtrusive and may not blend in with an historic interior. Polyester covers are being tested in a few National Trust libraries. Cut to the depth of the shelf and moulded to fit the profile of the tops of the books, they should provide protection without being visible to visitors (Fig. 17). If successful, this method has the potential to reduce quite dramatically the frequency of cleaning and its attendant risk of abrasion. Enclosures, such as 3-flap phase-wrappers or 4-flap phase-boxes can also be used to protect individual volumes, such as publisher's bindings,



Figure 17. Protecting books from dust deposition, using static grade polyester film on shelves above eye-level: (top shelf) unmoulded, i.e. laid over books; (bottom shelf) moulded, i.e. creased to follow contours.

but not as a method of mass protection. Shrink-wrapping books, used in some storage facilities, is not an option in historic libraries. In storage areas, pieces of archival card can be laid on top of books.

This study is now influencing housekeeping practice in historic libraries in the care of English Heritage and the National Trust. Book cleaning teams, whether staff or volunteers, are encouraged to look more closely at dust, assess dirt levels on individual shelves and map their assessments on a plan of the library presses. Mapping bookshelves gives a shelf-by-shelf analysis of cleaning needs and provides a basic guide to cleaning frequency for individual shelves. It also identifies the unexpected, e.g. dirty shelves far from visitor access, and prompts staff and conservators to investigate sources of dust unrelated to visitor activity (Fig. 15). As deposition rates vary up/down presses and across shelves, the frequency of cleaning can then be tailored to individual shelves. The cleaning regime should be regularly reviewed and changed whenever unusual events occur, e.g. building works or filming which may affect the distribution of dust.

Our studies of visitor perceptions of dustiness highlight the importance of communicating to visitors the ways in which libraries can be effectively preserved, together with an understanding of the effects of visitor activity on cleaning regimes and the conservation of individual books. Where there is no risk of mould, conservation activities can be shown to visitors as part of the visitor experience of a historic house, for example demonstrating simple book dusting techniques, together with the mapping of dust deposition.

CONCLUSIONS

When assessing the desirable frequency of cleaning in libraries, the fragility of book bindings should be taken into account. Where dust accumulates over long periods, there is a potential for it to become strongly cemented to surfaces through bacterial growth, formation of microcrystalline calcite, as well as humidity fluctuations causing fibre movement. As relative humidity is an important factor in this process, control of relative humidity is fundamental to the prevention of cumulative damage to books from dust and cleaning processes. Especially important are monitoring programmes, and cleaning schedules prior to seasonal cycles of high humidity.

It is essential that staff and volunteer book teams understand both the process of cementation and

visitor perceptions of dustiness, so that decisions on how often to clean are based on objective assessments of dust distribution and accumulation, and resources are directed where most needed. Scientific data also add force to debates with management over the need to spend scarce funds on new ways of preventing damage to collections.

To minimise deposition and hence frequency of cleaning in historic libraries, it is necessary to control visitor proximity to book presses, and visitor capacity and flow. It is also important to interpret to visitors the preventive conservation issues concerning dustiness, as their concerns over the appearance of rooms can impose more frequent cleaning than is good for the long term care of collections.

ACKNOWLEDGEMENTS

We are indebted to Chris Calnan (The National Trust) and Y H Yoon (formerly at University of East Anglia). Without their contributions to these studies of dust in historic libraries, we could never have written this paper. We also thank the house staff and book teams at Felbrigg Hall, Hughenden Manor and Audley End House for their help with measurements and assessments.

AUTHORS

Helen Lloyd.
The National Trust, Heelis, Kemble Drive,
Swindon, SN2 2NA, UK,
helen.lloyd@nationaltrust.org.uk

Caroline Bendix.
Wry Furlong, Welford Road, Sibbertoft,
Market Harborough LE16 9UJ, UK

Peter Brimblecombe
School of Environmental Sciences,
University of East Anglia,
Norwich NR4 7TJ, UK

David Thickett
English Heritage,
1 Waterhouse Square, 138 Holborn,
London EC1N 2ST, UK

HANWELL RH-T DATA LOGGER

For specification, see
<http://www.hanwell.com/pdf-industry/rh-t.pdf>
 Hanwell Instruments Limited
 12-13 Mead Business Centre
 Mead Lane
 Hertford SG13 7BJ,
 United Kingdom

Also stocked by:

Conservation By Design
 Timecare Works
 5 Singer Way, Woburn Road Industrial Estate'
 Kempston, Bedford MK42 7AW
 United Kingdom
info@conservation-by-design.co.uk
http://www.conservation-by-design.co.uk/equipment/hanwell_data_logger.html

POLYESTER FILM

Sold as Melinex® in the UK, and supplied by:
 Preservation Equipment
 Vinces Road, Diss, Norfolk IP22 4HQ
info@preservationequipment.com
www.preservationequipment.com

*GLOSSARY OF TERMS**PRESS OR STACK*

One vertical division within book-shelves

DUST FALL

A flap, usually made from leather or cloth, between 3-10cms deep and the same width as a book-shelf. It is usually attached to the underside of the leading edge of the shelf and hangs down from it in front of the tops of the spines of volumes on the shelf beneath.

3-FLAP PHASE WRAPPER

An enclosure made from archival board, which encloses all but the spine of the book.

4-FLAP PHASE WRAPPER

An enclosure made from archival board which completely encloses the book (also known as a phase-box).

A book produced already bound by the publisher but often without the text block (pages) having been trimmed.

REFERENCES

- 1 Lloyd, H., Brimblecombe, P. and Lithgow, K. (2007) 'Economics of dust', *Studies in Conservation* 52, 135-145.
- 2 Lloyd, H. and Lithgow, K. (2005) Physical agents of deterioration, in *The National Trust Manual of Housekeeping*, Elsevier/Butterworth-Heinemann, 55-67.
- 3 Bendix, C. and Pickwood, N. (2006) Books, in *The National Trust Manual of Housekeeping*, Elsevier/Butterworth-Heinemann, 475-487.
- 4 Bendix, C. and Walker, A. (2005) Cleaning books and documents, *Preservation in Practice Series*, National Preservation Office, <http://www.bl.uk/services/npo/pdf/clean.pdf>
- 5 HSE booklet – INDG 95 Respiratory sensitisers and COSHH (Rev2) 05/05, <http://www.hse.gov.uk/pubns/indg95.pdf>
- 6 Guild, S. and MacDonald, M. (2004) *Mould Prevention and Collection Recovery: Guidelines for Heritage Collections*, Canadian Conservation Institute, Technical Bulletin 26
- 7 Lloyd, H., Lithgow, K., Brimblecombe, P., Yoon, Y.H., Frame, K., and Knight, B. (2002) The effects of visitor activity on dust in historic collections, *The Conservator*, 26, 27-84.
- 8 Lawes, H., Bendix, C., Brimblecombe P., and Calnan, C. (2004) Three years of library dust, *Views*, 41, 27-30.
- 9 Bowden D. J. and Brimblecombe P. (2004) Monitoring dust at Ickworth House with the *Dust-Bug*, *Views* 42, 25-27.
- 10 Howell, D., Brimblecombe, P., Lloyd, H., Frame, K. and Knight, B. (2003) Monitoring dust in historic houses, In *Conservation Science 2002*, London: Archetype, 8-10
- 11 Yoon, Y.H., and Brimblecombe, P. (2004) Dust on books, *Views*, 41, 25-27.
- 12 Brimblecombe, P. (1987) *The Big Smoke*, Methuen, London, pp 185.
- 13 Lithgow, K., Brimblecombe, P., Lloyd, H., Thickett, D., and Yoon Y.H. (2005) Managing dust in historic houses – a visitor/conservator interface, in *Our cultural past - your future*, pre-prints of ICOM-CC 14th Triennial Meeting, Earthscan (James & James), 662-669.

- 14 Tarnowski, A., McNamara, C., Bearce, K., and Mitchell, R., 'Sticky microbes and dust on objects in historic houses', American Institute for the Conservation of Historic and Artistic Works (AIC) 32nd Annual Meeting, Portland, OR, 9–14 June 2004: Objects Specialty Group post-prints, vol. 11, American Institute for the Conservation of Historic and Artistic Works, Washington, DC, 11–28 (in press).
- 15 Marko, K. (1998) Care of textiles at Knole, in Historic Buildings Conference, National Trust, Knole, p.vii-viii.
- 16 Yoon, Y.H., Bowden, D.J., Brimblecombe, P. and Thickett, D. (2006) Formation of mudpacks on the bedspreads at Knole, *Views* 43, 61-62
- 17 Lithgow, K., and Brimblecombe, P. (2003) Dust, the visitors' point of view, *Views* 39, 47-49.
- 18 Lloyd, H., and Brimblecombe, P. (2003) Focussing on dust, *Views*, 39, 49-52.
- 19 Lithgow, K., Brimblecombe, P., Knight, B., and Julien, S. (2003) Visitor perceptions of dustiness, published on-line at <http://iaq.dk/iap.htm>, *Presentation Abstracts and Additional Notes from the 5th meeting of the Indoor Air Pollution Working Group: Indoor Air Quality in Museums and Historic Properties*, University of East Anglia, April 28-29
- 20 Lithgow, K. (2004) Conservation assistants and room stewards focus on dust, *Views* 41, 22-25.
- 21 Staniforth, S. (2006) Relative humidity as an agent of deterioration, in *The National Trust Manual of Housekeeping*, Elsevier/Butterworth-Heinemann, 103-113.
- 22 Yoon, Y.H., and Brimblecombe, P. (2004) A dust screen at Snowhill Manor, *Views*, 40, 42-44.

National Trust Views - PDFs of articles on dust research can be found at:
www.nationaltrust.org.uk/main/w-collections-dust



This work is licensed under a Creative Commons Attribution - Noncommercial - No Derivative Works 3.0 Licence.

LIBRARIES AND ARCHIVES IN HISTORIC BUILDINGS

DAVID THICKETT, SOEK-JOO RHEE AND SARAH LAMBARTH

ABSTRACT

The likely effects of major environmental parameters: temperature, relative humidity, light, dust and pollutant gases, have been studied in a range of historic libraries and archaeological archives. Paper lifetimes based on

time weighted preservation indices or cellulose isoperms exceeded those calculated from the maximum temperature and RH allowable under the standard BS5454. Light doses were found to be significantly below those expected from the blind management regime in place. Significant additional damage from light was not measured on the spines of leather bound books, which would be expected to receive the most light. Dust deposition was found to correlate strongly with human traffic, height and gap size between the book tops and the bottom of the shelf above.

INTRODUCTION

English Heritage is charged with caring for the nation's heritage. It manages twelve large historic houses with integral collections. Six of these have significant libraries, some with their original contents. English Heritage also holds over half a million archaeological objects from its approximately four hundred sites and their associated excavation archives. To maximise resources, the long term strategy is to move the archaeological stores out of commercial storage into historic buildings within English Heritage's estate. Close environmental control presents a number of difficulties in an historic building and it is even more difficult in a building open to the public. There is also a growing awareness that the large energy consumption of whole building close-control environment systems is unsustainable. This paper evaluates the preventive conservation of library and archive material in such situations. The major environmental parameters have been assessed in a representative set five historic libraries and three archives. Experimental methods are described in Appendix 1.

Temperature and relative humidity measurements were made both in the rooms and also in several microclimates within the rooms. The temperature and humidity data was used to calculate time weighted preservation indices for the less stable

more modern papers and media. For older books with purer cellulosic papers, the relative lifetimes were based on the isotherms for pure cellulose developed by Zou [1] and the worst conditions allowable under BS5454 [2] (21°C and 65% RH).

Light exposures were measured with radio-telemetry and stand-alone loggers and with blue wool standards. All of the historic house libraries have UV film on their windows and use light plans to set manually adjusted blinds to control the visible light exposure (see appendix 2). Natural light is the major light source, with some lamps used to illuminate dark areas or because they were originally present. The effects of other environmental parameters on the fading of blue wool standards were investigated by exposing them alongside the continuous monitors to compare the real and apparent dose. Extensive research into the light dosimeters developed by the LiDo project has highlighted environmental effects other than light on these sensors and there is some laboratory evidence that this is also the case for blue wool standards [3].

Within a book shelf, the spines of the books generally have by far the greatest light exposure. Whilst manually adjusted blinds can reliably achieve 200lux, suitable for cotton bindings, it is extremely difficult to achieve the 50lux specified for leather bindings [4]. The long term effects of higher light exposures were investigated through analysis of the state of deterioration of the leather.

Since books in the libraries of English Heritage Houses are rarely studied, the main handling of the books is during conservation cleaning. Optimising the period between cleaning is vital, as this activity is a major cause of damage. Another consequence of display rather than use, is that most dust deposition is onto the top edges of the books, followed by percolation down into the pages. The distribution of dust deposition throughout the libraries was measured with particular attention to deposition on these top edges and behind the books.

The ingress of chemical pollutants into libraries and archives has been studied with diffusion tube measurements for sulfur dioxide, nitrogen dioxide and ozone, and modelling of the indoor/outdoor ratios with the IMPACT applet combined with results

from the UK government's continuous monitoring network. Air exchange rates were determined for the library and archive rooms.

Different dehumidification methods were investigated in historic rooms housing archives. The use of heating systems induces temperature and RH distributions across rooms, which were investigated by placing series of sensors through a room. Their effects on the lifetime of paper were assessed from temperature and RH data.

Embrittlement of permatrace film was observed to be a major problem in the archaeological archives and was investigated further. Samples of permatrace were removed from edges containing no information. The type of film was identified with FTIR spectroscopy.

A selection of historic house libraries and archives was studied. They exhibited very different environments (with examples of urban, rural and maritime locations) and different management methods, including automatically and manually controlled conservation heating, comfort heating, dehumidification and high thermal mass. Light was controlled with UV films, neutral density films, manually adjusted blinds and black out blinds with artificial (mainly fluorescent) lighting.

THE HISTORIC LIBRARIES STUDIED

Audley End House is in a rural environment in Cambridgeshire. It has three adjacent libraries holding over twelve thousand volumes, the earliest dating from 1549. The house is open to the public eight months of the year. Light exposure is controlled by manually adjusting blinds on the UV filtered windows to give 200 lux. Because of the short daily opening hours and closure over winter, this is equivalent to an annual dose of 156430 lux hours. The environment is controlled through conservation heating (RH controlled) via oil filled electric radiators controlled by individual hygrostats.

Brodsworth Hall, again in a rural environment, has a much smaller library housed in a single room. The house is open to the public for eight months and closed over the winter. The library has important views of the gardens through the window closest to the books. The light levels in the library are controlled by the application of MT40 neutral density and UV film and lowering the blind only when 200 lux is exceeded. The RH in the library is regulated through a Building Management System

(BMS) controlled water radiator system applying conservation heating.

Eltham Palace is in an urban environment in South East London and is open ten months of the year, closing January and February. The library houses twentieth century books in a single study. Light is controlled by a light plan to 200 lux. The room is heated using hot water panels in the ceiling, controlled by a central thermostat.

The Iveagh Bequest at Kenwood is in another London urban environment. It is open 364 days of the year. The Robert Adam designed library houses two thousand books. The library has large south facing windows with UV filtration. The light levels are controlled manually by blinds on a light plan to 200 lux. The heating is run for human comfort and is a water radiator system run off a thermostat compensated for the outdoor temperature.

Walmer Castle is in a maritime environment. The Duke of Wellington's room is presented as it was in 1854, when he died there. It has a single set of bookshelves covering a damp interior wall. Winter heating is through a water radiator system controlled by a compensated thermostat. Light is controlled by manually adjusted blinds.

ARCHAEOLOGICAL ARCHIVES STUDIED

Dover Castle holds the archaeological archives of ten sites. The archives are stored in a single room in a 1912 stone building. The archive room is controlled with conservation heating using a manually adjusted electric radiator. The room has black out blinds and filtered fluorescent lighting providing 150 lux at the surface where the archives are studied. Dover has high dust and pollution from the adjacent ferry port and a very high volume of freight traffic.

Atcham store is a modern commercial industrial unit holding the archaeological archives from the very extensive excavations at Wroxeter Roman City. The archive is stored in a metal container unit with a Munters dehumidifier keeping the RH below 60%. The only light sources are UV filtered fluorescent tubes.

Corbridge Roman Museum was purpose built as a museum in the 1980s. It holds the archives from the excavations at Corbridge in a basement store. The high thermal mass of the basement gives stable conditions. The store and study area are lit with filtered fluorescent lamps.

		Proportion of collection			Cellulose lifetime relative to BS5454	TWPI (years)	TWPI relative to maximum values allowed by BS5454	Air exchange Rate (day ⁻¹)
		<1840	1840-1900	>1900				
Audley end	Library	45	45	10	1.21	46	1.24	6.7
	Behind shelves (4)				1.18-1.24	44-49	1.19-1.32	
Brodsworth	Library	60	40	-	1.23	56	1.51	8.2
	Behind shelves (2)				1.20-1.15	54-57	1.46-1.54	
Eltham	Library	8	19	73	1.77	42	1.14	6.2
Kenwood	Library	29	36	35	1.12	41	1.11	12.4
	Behind shelves (5)				1.09-1.13	38-41	1.03-1.11	
Walmer	Library	95	5	-	0.98	37	1.00	22.4
	Behind shelves (1)				0.81	29	0.78	
Dover	Store	-	-	100	1.21	52	1.41	3.2
	Enclosures (5)				1.11-1.34			
Atcham	Store	-	-	100	1.02	57	1.54	2.1
	Enclosures (5)				0.96-1.23			
Corbridge	Store	-	-	100	1.57	55	1.49	ND
	Enclosures (5)				1.43-1.61			

Table 1; Collections, calculated lifetimes and measured air exchange rates.

RESULTS

THERMOHYGROMETRIC LIFETIMES

The time weighted preservation indices and relative cellulose deterioration rates are shown in Table 1. In all but three instances the TWPI was higher and the deterioration rates lower than those equivalent to the maximum values allowed by BS5454 [5]. This is due to the low level of heating used in these spaces.

The relative effect of conservation heating depends on the hygric response of the space. A simple calculation comparing regions of the psychrometric chart with isoperm data for TWPI would indicate that controlling the RH between 50 and 65% by conservation heating would be likely to slightly decrease the chemical lifetime of the paper at the higher RHs and temperatures and slightly increase it at the lower RHs and temperatures. Isoperm data derived from Zou would indicate a slight decrease in chemical lifetime for pure cellulose papers. However, this approach only considered the air and the paper. The internal conditions within a building vary greatly. Some are relatively dry and in that instance the major effect of conservation heating is to reduce temperatures from those expected from comfort heating, hence increasing lifetime. With damp building fabrics, conservation heating can produce positive feedback, driving more water out of the walls and actually increasing the RH (and dramatically decreasing lifetimes). Conservation heating will not work in some circumstances.

When English Heritage acquired Brodsworth hall in 1990, a three year monitoring campaign was undertaken with just low level heating for frost protection in place. This is the minimum level of heating that would ever be considered for an important historic property. The average TWPI and cellulose lifetimes over the heating period (October to May) for the library were 61 years and 1.21. Extensive modelling of the internal environment using the Energy Plus program [6] indicated that with conservation heating with limits of 50 and 65% installed into this (and adjacent) spaces, the figures would be 57 years and 0.98. The average of the monitored data over the past three years with this system in place has been 56 years and 1.47. Hence the conservation heating has decreased the TWPI, but increases the predicted lifetime of pure cellulose. These apparently contradictory results are due to the different balance between the effects of increasing temperature and RH on the two predictions. Since around 60% of the books in Brodsworth's library are likely to be printed on cotton rag paper, the majority of the collection is benefiting from conditions likely to prolong its lifetime.

Only one instance of a significantly different environment behind the books was observed at Walmer Castle. The archaeological archive spaces all had much longer chemical lifetimes. The enclosures used to store the archive material provided very little thermal buffering and some short term RH buffering, but this buffering had little effect on the lifetimes over a longer period. Many records of archaeological excavations are on poor quality paper, prone to rapid deterioration.

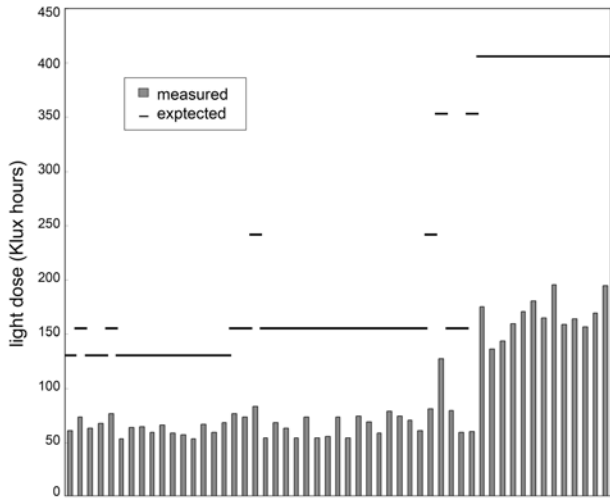

Figure 1. Measured and expected light doses in 52 locations. The expected dose is less than 60% of that expected from the light plan in all instances.

Recent guidelines on archaeological archives now recommend using archival quality material to record the excavation information [7].

LIGHT EXPOSURES

The light doses measured in the libraries were all significantly less than equivalent to the specified 200 lux. Individual light measurements were over 200 lux, but the accumulated dose corresponded to a much lower average intensity. This result has very important consequences for the use of light plans. Further data were examined from twenty seven other continuously monitored rooms and another twenty four rooms monitored with blue wool dosimeters. In all instances the dose experienced was under 60% of that laid out in the light plan (figure 1). This appears to verify that the use of natural side lighting controlled by manually adjusted blinds and light plans produces much lower light doses than expected from the light plans. This allows a number of options. The light plans can be retained unaltered, knowing that the doses will be lower than stated. Many historic libraries contain a wide variety of materials included silk, Audley End has silk embroidered furniture and Brodsworth has original silk fronted cabinets. These materials are often more light sensitive and would benefit from a lower dose.

Alternatively, light levels may be increased to produce the doses that have already been accepted at object surfaces. Within English Heritage, all light plans have curatorial input. Low light levels are amongst the most common cause of visitor complaints to historic properties. A five year project

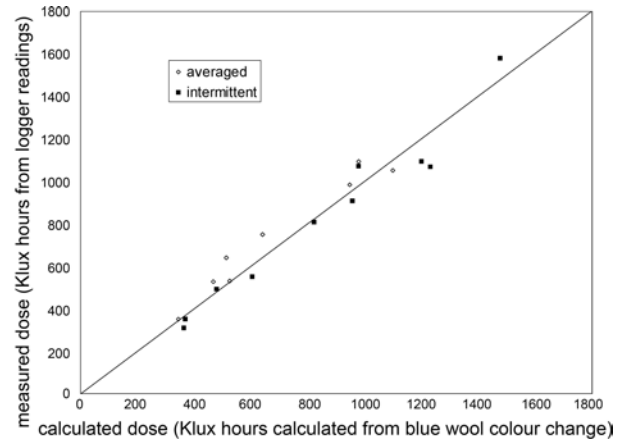

Figure 2. Accuracy of Blue Wool Dosimeter measurements in real situations. The dose calculated from blue wool colour change is plotted against dose determined by illumination measurement for both the intermittent and the more accurate averaged measurements.

is presently underway to determine real fading rates and the rates of chemical damage for silks and wooden furniture.

Comparison of the light doses determined with blue wool dosimeters and using continuous monitoring showed that the variation of the blue wool fading, due to other environmental factors, was approximately 30% (figure 2). The measurement error for the spectrophotometric

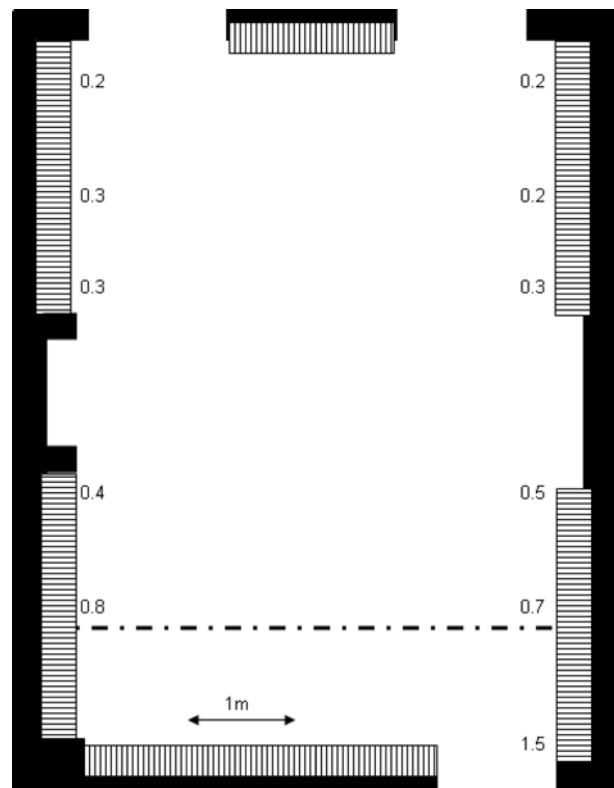

Figure 3. Dust deposition in the library at Eltham House, South West London. The numbers are dust deposition rates measured as percentage coverage of a glass slide exposed for 30 days. The values drop off as the distance from the barrier (marked by dotted line) increases. All measurements were made at 1m height.

determination of ΔE_{76} was estimated at 3.5% from replicate measurements. Precise repositioning of the spectrophotometer head was achieved using Melinex masks built into the dosimeters and the view-through facility of the instrument, whilst the orientation of the spectrophotometer head against the blue wool fabric weave was controlled by the dosimeter design. Fitting the ΔE_{76} values to the empirical calibration curve derived by Bullock and Saunders will introduce further errors, estimated to give a total error for the measurement and fitting of 5%. The radiotelemetry based light sensors transmit data every hour, so doses calculated from these data for rapidly varying natural light levels will be less accurate than the measurement error of 5%. The loggers used were set to record averaged light levels for the sixty minute logging intervals and the errors in the doses calculated will be predominantly

determined by the measurement error of the light intensity, which was 5%.

Analysis of identical leathers exposed and shaded from relatively high light doses showed no significant increase in deterioration in the libraries studied. Samples were taken from either the same book binding on the spine and light shaded cover; or from known identical samples one of which faced the windows, the other being shaded. Light control was not as rigorous in some properties in the past and evidence of very dramatic fading is present on other parts of the collections, known to have been exposed under those early lighting regimes. Table 2 shows the sets of FTIR, polarised FTIR and moisture regain values. Within the precision of these methods no significant increase in deterioration through light was observed.

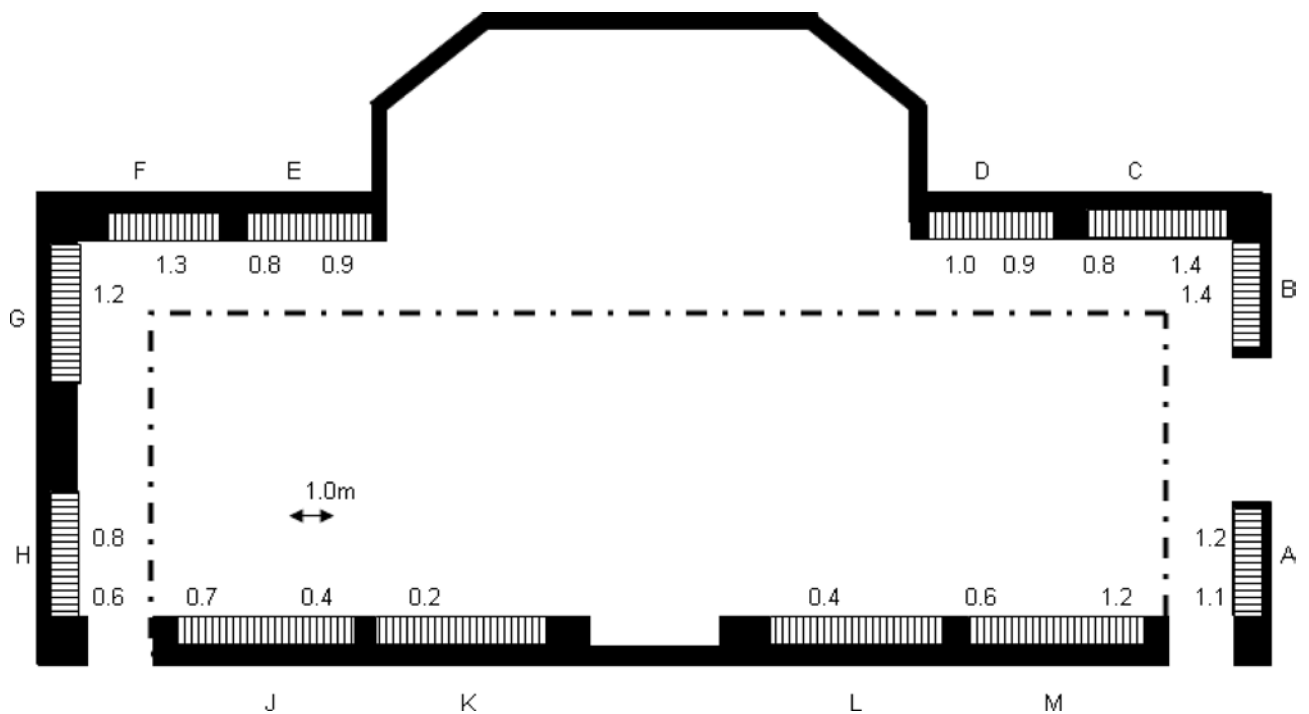

Figure 4. Dust deposition in Great Library at Audley End House, Cambridgeshire. Letters are book case identifiers. Numbers are dust deposition rate measured as percentage coverage of a glass slide exposed for 30 days. Deposition rate is higher at beginning of tour route, bookcase A and where the tour route turns book cases B and F.

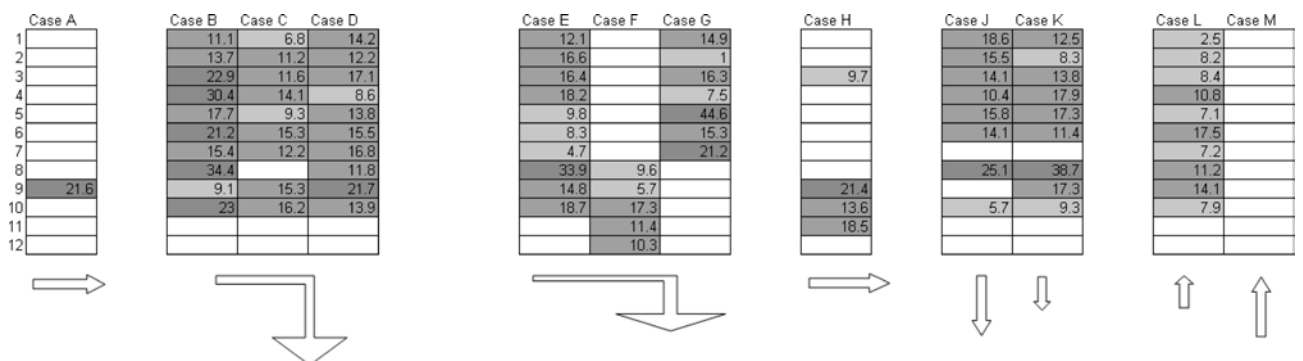

Figure 5. Long term dust deposition over shelves in Audley End House library. The numbers represent the loss of gloss on wooden shelves caused by the deposited dust. The readings are coded as a grey scale to clarify the overall pattern. Arrows represent the tour route. This long term data reinforces the conclusions from Figure 4.

Sample	Date	FTIR	Amide III dichroism ratio	moisture regain (°C)
AEH 1 exp	1821		4.5 ± 0.4	ND
AEH 1 unexp			4.8 ± 0.6	ND
AEH 2 exp	1798	Vw	3.5 ± 0.7	0.84
AEH 2 unexp		Vw	3.4 ± 0.6	0.82
AEH 3 exp	1840		3.7 ± 0.6	ND
AEH 3 unexp			3.6 ± 0.	ND
AEH 4 exp	1798	W	3.2 ± 0.6	1.15
AEH 4 unexp		W	3.1 ± 0.5	1.14
AEH 5 exp	1707		3.6 ± 0.7	ND
AEH 5 unexp			3.7 ± 0.7	ND
AEH 6 exp	1781		3.1 ± 0.5	1.23
AEH 6 unexp			3.2 ± 0.6	1.20
AEH 7 exp	1802	Vw	2.4 ± 0.7	1.44
AEH 7 unexp		Vw	2.1 ± 0.5	1.47
AEH 8 exp	1789		3.6 ± 0.4	ND
AEH 8 unexp			3.7 ± 0.5	ND
Kenwood false exp	1950-70	ND	ND	1.37
Kewood false unexp	1950-70	ND	ND	1.39

Table 2; Leather deterioration measurements with FTIR and moisture regain. See the appendix for an explanation of the measurements.

DUST DEPOSITION

Dust deposition in the open parts of libraries followed patterns previously observed in other display rooms [8]. The dust deposition dropped exponentially with distance from the tour route (figure 3). It was highest at points where the tour route turned corners (figures 4 and 5). The vertical deposition profiles on the front edge of shelves had maxima at low level and at approximately 1m (figure 6). The ingress of dust behind the books and its deposition onto the top book edges could be defined as two different types of behaviour, determined predominantly by the gap between the top of the books and the shelf above. With a gap greater than about 20 mm, the profile along the

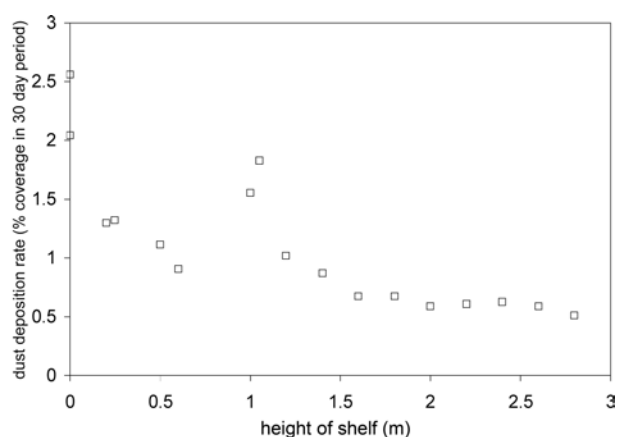

Figure 6. Dust deposition in the library at Brodsworth House, Yorkshire plotted against shelf height from floor. Glass slides were placed on the front of the shelves and the percentage coverage of deposited dust measured after 30 days. There is a maximum near floor level, with a second maximum at approximately 1m height and then a diminution. Heights were limited by available shelves.

top edge dropped approximately linearly (figure 7). With smaller gaps, the profile has a more exponential character. Dust did not penetrate as deeply and dust deposition levels behind the books were much lower. Dust deposition levels behind books are of critical importance when book shelves are on wet walls, as a higher RH microclimate can develop behind the books, as at Walmer Castle. These higher RHs encourage cementation of the dust, bind it more strongly to the paper and mean that more aggressive cleaning methods are required for its removal. Comparative values are given in Table 3.

Dust deposition in the archaeological archive rooms follows very different patterns, as it is not dominated by

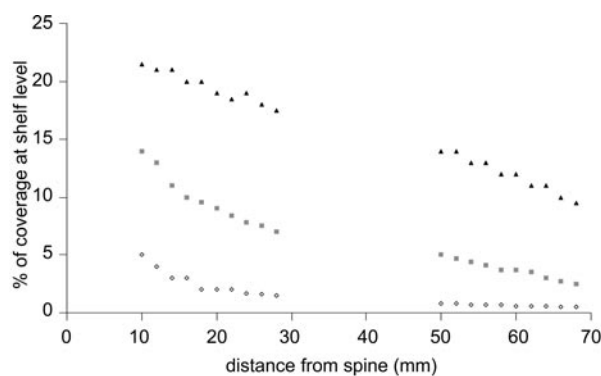

Figure 7. Dust deposition onto the top edges of books with different gap sizes between the top of book and the shelf above. Glass slides were placed along top edges of books and analysed after 30 days exposure. Dust deposition is expressed as a percentage of that occurring on the shelf at the front of the book to account for different positions of books within a library. Two different behaviours are observed, with larger gap sizes showing almost linear decay, whilst smaller gap sizes show more exponential decay.

Location	Dust Deposition Rate Range Overall (%/30days)	Dust Deposition Rate Range Adjacent to tour route at 1m height (%/30days)
Audley End House Library	0.20 - 1.83	0.62 – 1.76
Brodsworth Hall Library	0.48 – 1.45	1.04 – 1.45
Eltham Library	0.20 – 1.51	0.98 – 1.51
Kenwood House Library	0.67 – 2.05	1.34 – 2.05
Walmer Library	0.75 – 4.56	0.95 – 4.56
Dover Archive	0.04 – 0.33	0.04 – 0.33
Atcham Archive	0.03 – 0.25	0.03 – 0.25
Corbridge Archive	0.04 – 0.12	0.04 – 0.12

Table 3; Dust Deposition Rates Measured in Historic Libraries and Archives. Right hand column is subset of results attempting to standardise measurements and take into account effects of distances from visitors and height.

Location	Pollution Concentration Range (ppb)		
	Sulfur dioxide	Nitrogen dioxide	ozone
Brodsworth external	0.75-0.98	4.50-6.56	25.3-33.8
Brodsworth library	0.26-0.61	3.70-4.25	0.98-1.39
Kenwood external	1.21-1.81	34.2-44.7	16.4-33.4
Kenwood library	0.26-0.62	5.08-6.54	0.68-1.25
Kenwood behind books	0.23-0.64	4.70-5.98	0.53-0.98
Dover external	2.43-3.23	6.54-8.65	12.80-14.67
Dover archive room	0.20-0.41	0.20-0.41	0.99-1.53

Table 4; Pollution Measurements in Libraries and Archives

coarse dust from visitors. Even the archive at Dover, which suffers particulate pollution from the nearby ferry port and associated heavy diesel traffic, has very significantly lower deposition rates than any of the historic libraries.

POLLUTANT GASES

The pollutant gas concentrations are shown in Table 3. The archives had lower pollution concentrations due to their much lower ventilation rates. The results of the IMPACT modelling from the Dover archaeological archive are shown in Figure 8. As can

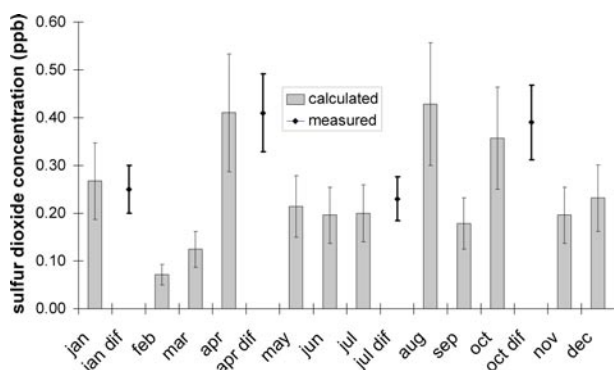

Figure 8. Pollution modelling and measurement in the Archaeological Archive Room at Dover Castle, Kent. Sulfur dioxide concentrations were calculated from the IMPACT applet, the measured air exchange rate of the room and external measurements from Dover Port authority monitoring station. Internal measurements were by diffusion tube.

be seen the model produced reasonable agreement with the measured values. Setting reasonable limits for pollution concentrations for papers is complicated by the fact that their response varies by a factor of over 100 depending on manufacture [9]. The indoor/outdoor ratios for the archive are comparable to the values quoted for filtered air conditioned buildings [9]. The libraries perform well with ozone, but much less so for nitrogen dioxide and sulfur dioxide. However, in those locations the external sulfur dioxide concentration was low, due to Brodsworth Hall's rural setting and Kenwood House being set back in its grounds.

CONCLUSIONS

Several authors have argued that standards for archives and libraries based on physical response are unnecessarily prescriptive and often do not address the fundamental issue of chemical decay of the paper and associated materials [2, 10]. The relatively little handling of books in libraries in historic houses, is an extreme case and standards based on physical response are largely irrelevant. The chemical lifetimes calculated from extensive monitoring are actually lower in most cases than the lifetimes predicted from the maximum allowed temperature and relative humidity under BS5454.

The light doses measured in rooms with blinds controlled manually to a light plan have been found to be significantly under the levels anticipated from the plans. This has been confirmed in a large number of cases. This allows a number of approaches, from increasing the figures on the plans to achieve the desired doses to retaining the lower doses and accepting the impairment of visitor experience.

Dust deposition is of critical importance as it drives the most damaging handling process that the books undergo: cleaning. The general principles of distribution of dust from visitors have been confirmed to operate in historic libraries. Different mechanisms of dust penetration into book shelves have been observed, controlled largely by the gap above the books.

Gaseous pollution also causes chemical damage. Sulfur dioxide concentrations were low, even in highly polluted sites. The effect of the oxidising pollutants nitrogen dioxide and ozone is less studied and it is difficult to interpret the likely effects of the concentrations measured. The ratios against the outdoor concentrations appear to be comparable with figures published for chemically filtered buildings.

AUTHORS

David Thickett, Soek-Joo Rhee
and Sarah Lambarth
English Heritage,
1 Waterhouse Square, 138 Holborn,
London, EC1N 2ST,
david.thickett@english-heritage.org.uk

ACKNOWLEDGEMENTS

The authors would like to acknowledge the assistance given by English Heritage curators Caroline Cartwright, Laura Holliston, Allison Sharpe, Rowena Willard-Wright, Pam Braddock and the registrar Trevor Reynolds. Caroline Gunn, Senior Building Services Engineer for the thermography. Historic Royal Palaces for access to image analysis for dust measurement and the Tate Gallery for the kind loan of the Gepruft gloss meter.

REFERENCES

- 1 X. Zou, N. Gurngul, T. Uesaka and J. Bouchard, 1994, Accelerated aging of papers of pure cellulose: mechanism of cellulose degradation, *Polymer degradation and stability*, 43, 3393-402
- 2 B. Pretzel, 2005. The RIBA project: a climate strategy for paper-based archives at the Victoria and Albert Museum, *Preprints of 14th Meeting of ICOM-CC*, The Hague, 681-688
- 3 L. Bullock and D. Saunders, 1999. Measurement of cumulative exposure using blue wool standards, *Preprints of 12th Meeting of ICOM-CC*, Lyon, 21-26
- 4 A. Angus, M. Kite and T. Sturge, 2006. 'General principles of care, storage and display' in eds: M. Kite and R. Thomson, *Conservation of Leather and Related Materials*, Butterworth-Heinemann, London, 115
- 5 BS5454 2000. *Recommendations for the storage and display of archival documents*, British Standards Institute
- 6 J. Taylor, N. Blades, M. Cassar and I. Ridley, 2005. Reviewing past environments in a historic house library using building simulation, *Preprints of the 14th Meeting of ICOM-CC*, The Hague, 708-715
- 7 D. Brown, 2007, *Archaeological Archives: A Guide to best practice in Creation, Compilation, Transfer and Curation*, Archaeological Archives Forum, downloaded from <http://www.archaeologists.net/modules/icontent/index.php> on 10 August 2007
- 8 H. Lloyd, K. Lithgow, P. Brimblecombe, Y.H. Hoon, K. Frame and B. Knight, 2002. The effects of visitor activity on dust in historic collections, *The Conservator*, 26, 72-84
- 9 J. Tetrault, 2003. *Airborne Pollutants in Museums, Galleries and Archives*, Canadian Conservation Institute, Ottawa, 118-133
- 10 S. Michalski, 2002. 'Double the life for each five degree drop, more than double the life for each halving of relative humidity', *Preprints of 13th Meeting of ICOM-CC*, Rio, 66-72
- 11 Y. Ichihara and Y. Matsuda, 2006. Examination of degradation behaviour of book binding leather using FTIR spectroscopy, *Postprints of Seventh Biennial Gathering of the Infrared and Raman Users Group*.
- 12 G.S. Young, 1992. Loss of infrared linear dichroism in collagen fibres as a measure of deterioration in skin and semi-tanned leather artifacts, *Materials Research Society Proceedings*, 859-867
- 13 C. Calnan and C. Thornton, 1996, 'Determination of moisture loss and regain', *Environment Leather Project, Deterioration and Conservation of Vegetable Tanned Leather. Research Report 6*, 17-22
- 14 Howell, D., Brimblecombe, P. Lloyd, H. Frame, K. and Knight, B. 2002.

- Monitoring dust in historic houses. In: J.H. Townsend, K. Eremin and A. Adriaens, eds. Conservation Science 2002. London. 8–11
- 15 Adams, S., P. Brimblecombe, et al. 2001. 'Comparison of two methods for measuring the deposition of indoor dust. *The Conservator* 25: 90–94.
- 16 N. Blades, D. Kappa and M. Cassar, 2002. Development of a web based tool for predicting the occurrence of pollutants inside museum buildings, *Preprints of the 13th Meeting of ICOM-CC*, Rio, 9-14
- 17 ASTM E741–00, 2000, Standard Test Method for Determining Air Change in a Single Zone by Means of Tracer Gas Dilution, ASTM E741–00, ASTM International

APPENDIX I: METHODS

Temperature and humidity was monitored with a Meaco radio telemetry system over a number of years. The temperature and relative humidity behind the books on the shelves was monitored for a one year period with either the Meaco radio telemetry system or Hanwell Humbug data-loggers. The temperature and RH in several types of enclosure used for archives was monitored and simple models developed and tested to relate this to the room environment.

The light exposures were monitored with either Elsec light monitors connected to a Meaco radio telemetry system, Hanwell luxbug data-loggers or blue wool standards. The calibration of the electronic loggers was checked before the measurements against a commercially calibrated probe using a daylight source.

Small samples of leather were taken from damaged bindings of books that had very high light exposures in their past. Both sides of the samples were analysed with Fourier Transform infra-red spectroscopy using a diamond attenuated total reflectance accessory. The samples were taken from the lower fore-edge of the binding, such that the outer face would have had a much greater light exposure than the inside face. Large changes in the leather structure can be determined from the overall spectrum [11]. Analyses of the dichroism of the amide III bands of single fibres gives a much more sensitive probe of the state of deterioration of the leather [12]. Eight fibres residing mainly on the surface were taken from the back and front of each sample for this analysis. Moisture regain measurements were taken on eight books by measuring the surface temperature rise of the spine and one sleeve as the RH

was raised from 40% to 70% inside a showcase using preconditioned artsorb [13]. The surface temperatures were measured with PT100 sensors attached to ACR SR008 loggers. Similar measurements were taken in situ on two contemporary leather false book panels using a humidifier to control the RH under a plastic tent. Series of book spines were assessed similarly using an Infotronics thermal camera to measure the evolution of surface temperature of a large number of books simultaneously.

Dust was monitored by exposing clean glass slides and measuring the amount of dust deposited using microscopy and image analysis [14]. Slides were exposed on the book shelves, on the top edges of the books and behind the books on the shelves. The slides on the top edges of the books were analysed to determine the pattern of dust deposition with distance from the spine. One of the libraries had not been cleaned for two years and attempts were made to determine the long term deposition rate. A Gepruft Tri-microgloss M gloss meter was used to take measurements at 60° on each book shelf in the library, that portion of the shelf was then cleaned with a microfibre cloth and the gloss re-measured at exactly the same point. The increase in gloss is a measure of the dust present initially on the shelf [15]. Several of the shelves had books too close to the edge to accommodate the gloss meter, but measurements were obtained from over 75% of the shelves.

Pollution was measured in the rooms using commercially available diffusion tubes. These measured the average concentrations of sulphur dioxide, nitrogen dioxide, ozone and hydrogen chloride gases over the four week measurement period. Where possible, tubes, were exposed externally (on the roof on a north facing wall), in the room and behind the books on a shelf. Measurements were taken every three months, over a year. Room air exchange rates were measured with tracer gas methods, either sulfur hexafluoride or carbon dioxide. Where external pollution data exist, the internal concentrations in the libraries and archives were calculated from this and the air exchange rates, internal temperatures and RHs, using the IMPACT applet [16].

The air exchange rates of the rooms were measured using carbon dioxide or sulfur hexafluoride tracer gas decay [17] with Vaisala GMP222 loggers. Air exchange through gaps between the tops of books and the shelf above was investigated using carbon dioxide tracer gas decay. Carbon dioxide loggers were placed behind the books. Carbon dioxide was introduced into the space behind the books and its

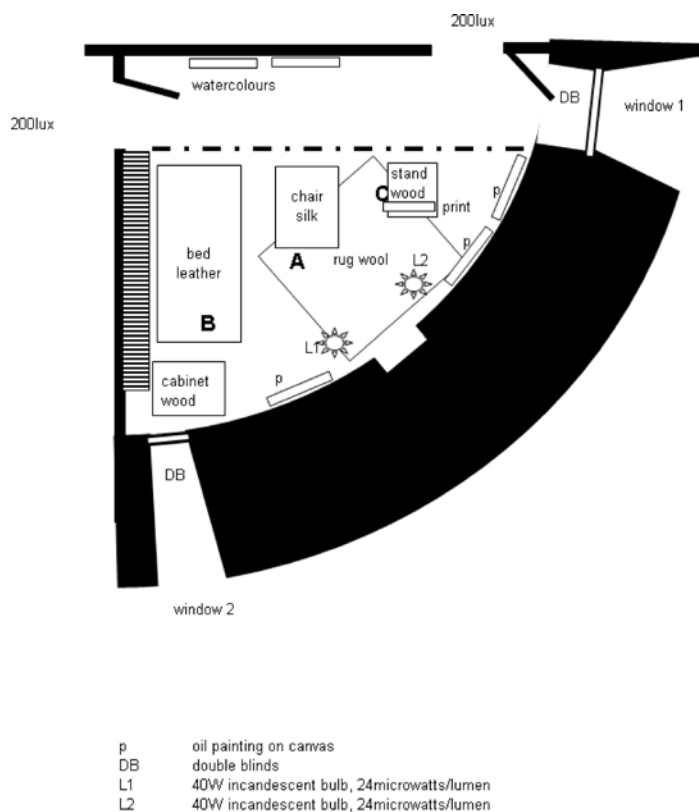

Position	Blinds			Shutters	
	Up	Midway	Down	Lights	Lights
A					
B					
C					
D					

Room: Duke of Wellington's	Date: 20/02/2002			
Room				
Contents to be considered:				
Chintz armchair Silk bedcovers Bed (leather and canvas) Wallpaper (replica) Carpet (replica) Curtains (replica) Prints (watercolour and monochrome) Books Wooden tables Wooden chair Wooden book stand				
Light Sources:				
Two windows, two electric lights on fireplace				
UV control measures:				
UV film on both windows				
Light control measures:				
Dark coloured Holland blinds and curtains on both windows, electric				
Light control:				
	Open Hours	Closed Hours	Closed Season	Functions
Proposed:	Eastern blind ¾ closed Southern blind fully closed	Blinds and curtains fully closed	Blinds and curtains fully closed	N/A
Desired lux level at recommended monitoring points when open to the				
Maximum of 50 lux on armchair and bed.				

Monitoring Points

- A - Vertically at top of the armchair back
- B - Horizontally on edge of silk bedcover, on corner nearest to chair
- C - Vertically in middle of print on bookstand

Figure 9. An example of a light plan. This is for the Wellington Library at Walmer Castle, Kent. Vulnerable objects, light sources and controls and illumination measurement points are marked. Probable initial blind levels are included in the table, but blinds are set to the illumination level specified at the measurement points

decay examined. An air exchange rate for that shelf of books was calculated from the slope of the natural logarithm decay regression.

APPENDIX 2; LIGHT PLANS

The highly variable nature of natural illumination and differential penetration into rooms makes manual adjustment of blinds to achieve set light exposures a complex task. Light plans aim to simplify this procedure. The plan sets initial blind levels in the morning and afternoon at different times of the year. The plan defines two to four measuring points for the illumination level and what lux should be recorded at those points to provide the desired illumination throughout the room. There is obviously a very significant element of compromise with illumination levels throughout the room. The light plan is developed by mapping the sensitivities of objects in the room, its orientation, the sky map from the windows, all the light sources and the illumination levels in adjacent sets of rooms. The preservation of historic views through open windows interferes with the accommodation of the eye to lower illumination levels and makes managing

illumination and visitor experience in a naturally lit historic building more challenging than within an artificially lit building. A series of measurements throughout the year define the measurement points and set illumination levels for the light plan. The plans are refined constantly. An example for a single room is shown in Figure 9.

SUPPLIERS

HUMBUGS AND LUXBUGS

Hanwell Instruments Limited
 12-13 Mead Business Centre
 Mead Lane
 Hertford SG13 7BJ
 T: 0870 443 1786
 enquiries@hanwell.com

RADIOTELEMETRY RH AND LIGHT MONITORING

Meaco
 Unit 62 Smithbrook Kilns,
 Cranleigh,

Surrey,
GU6 8JJ
United Kingdom
Telephone 01483 267433
Fax 01483 267422
E-Mail sales@meaco.com

BLUE WOOL STANDARDS

The Society of Dyers and Colourists
PO Box 244
Perkin House
82 Grattan Road, Bradford
West Yorkshire BD1 2JB
Tel: 01274 725138
Fax: 01274 392888

ACR LOGGERS

ACR Systems Incorporated
Building 210-12960 84 Avenue
Surrey, British Columbia V3W 1K7
Canada
Tel+1 (800) 6637845
www.acrsystems.com

DIFFUSION TUBE POLLUTION ANALYSIS

Gradko International Limited
St. Martins House
77 Wales Street
Winchester, Hampshire SO23 0RH
England
Tel: +44 (0) 1962 860331
Fax: +44 (0) 1962 841339
Email: sales@gradko.co.uk

CARBON DIOXIDE LOGGERS

Vaisala Ltd
Mr. David Cridland
Unit 9, Swan Lane
Exning
NEWMARKET
Suffolk CB8 7FN
GREAT BRITAIN
Tel. +44-1638-576200
Fax. +44-1638-576240
uksales@vaisala.com
www.vaisala.com



This work is licensed under a Creative Commons Attribution - Noncommercial - No Derivative Works 3.0 Licence.

WHY KEEP CLIMATE RECORDS - AND HOW TO KEEP THEM

TIM PADFIELD

ABSTRACT

For all our concern about the damage caused to art by the environment, there are no data which allow us to connect measured environmental variables with the rate of deterioration of the art in exhibition or storage. Recent proposals for rating the suitability of spaces and the vulnerability of individual objects require a durability of electronic data which is very unlikely to be achieved. This is a review of the state of the art of recording the environment around art.



Figure 1. The human readability of analog records produced by thermohygrographs gives many advantages. For quality control, rather than research, the thermohygrograph still has a role to play in museums.

INTRODUCTION

Climate records are evidence of care. The thermohygrograph ticking quietly in the corner of an exhibition announces the professional standard of the institution even if its ink line wanders shakily up and down on the graph. The ritual aura of the thermohygrograph, with its public display of the room climate and its evidence of a human visit once a week, has now been lost as this long lived instrument has nearly universally been replaced by digital sensors. The loss is more serious than the disappearance of a comfortingly familiar gallery exhibit. The digital records are vulnerable to erasure. They are doomed to loss by format obsolescence unless converted into a durable standard format. The digital storage media are of uncertain physical durability. One cannot assume that digital recorders are more accurate than the thermohygrograph.

THE NEED FOR DURABLE RECORDS

There are several recent initiatives in preventive conservation which require environmental records for individual objects or exhibition rooms stretching back, ideally to the birth of the object.

The first of these data hungry proposals is the call to limit exposure of light sensitive objects to a lifetime dose. This is based on the good evidence that photochemical damage accumulates according to the total photon dose rather than the light intensity in photons per second. A dim light will eventually cause the same damage as a bright light will cause quickly. Light intensity in an exhibition varies much from place to place, and from time to time if there is daylight. One would have permanently to fix a photon counter to every object, maybe on several surfaces. This can be done, in the same way security tags are fixed to items in shops. However, what is the chance that the communication and storage format for these devices will not change in the thousand years that is the conservator's perspective in matters

Momentous decisions in archaeology: Tutankhamun

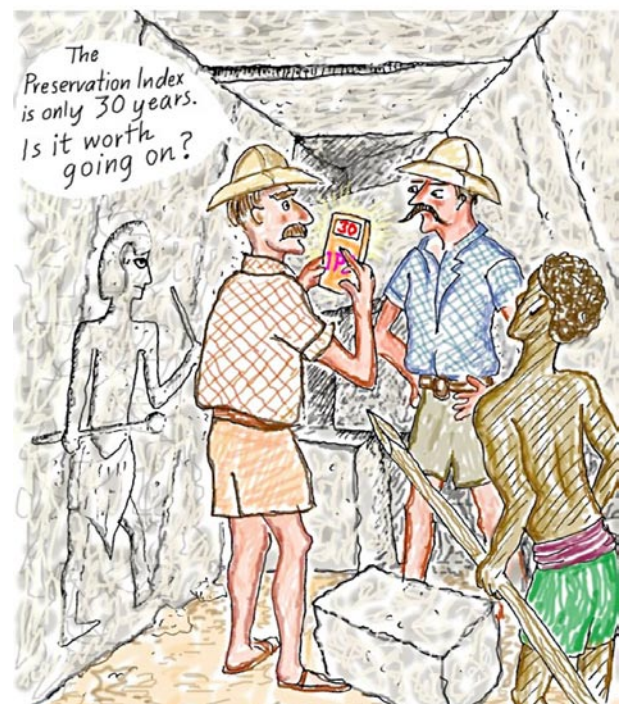

Figure 2. The Image Permanence Institute has developed a data logging and reporting system which measures temperature and relative humidity, from which it derives a preservation index in expected years of life for an object in that environment. The indicated lifetime is rather pessimistic.

of durability? The blue wool standards remain the most durable device to measure accumulating light exposure.

The second example of the need for durable records is the Image Permanence Institute's (IPI) Preservation Environment Monitor and Climate Notebook [1,2]. The hardware provides a readout of the Time Weighted Preservation Index (TWPI), which is an arcane measure of the rate of damage predicted from the temperature and relative humidity recorded since the logger was switched on. This number, though expressed as years of useful life for the object, is not based on the nature of the object but on its environment, so only one logger is needed per room. The calculation is presented every few seconds but only gives a true indication of the quality of the environment on the anniversaries of its first measurement. This is because the annual climate cycle has a strong influence on the number, unless the room is air conditioned, in which case the TWPI will be constant and needs only a single reading. The TWPI for a comfortably warm room predicts a lifetime for its contents around 50 years, but for an open sided barn in northern Europe it is 150 years. So there should not be much old stuff left indoors. The fact that most things do actually survive much longer seems not to have dented trust in the TWPI. There is, however, a fundamental insecurity in relying on



Figure 3. A carved ivory tusk from Africa, almost invisible in the glare of the sunlight warming its showcase. The room temperature and RH were acceptable but a datalogger within the case registered an extreme local climate (figure 4)

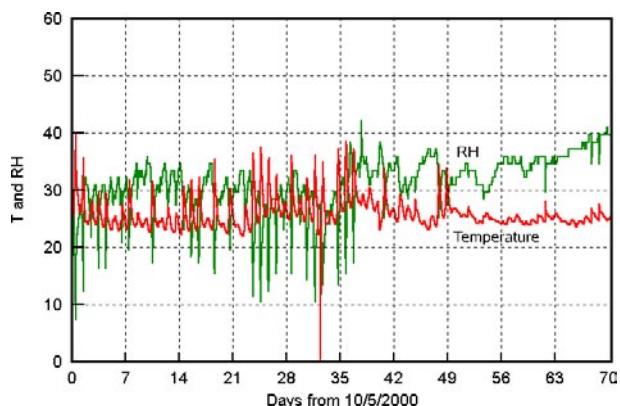

Figure 4. The climate measured inside the case shown in figure 3. The datalogger, set in the relative cool of the base of the case, was ivory coloured to ensure that it experienced the same radiant heating as the object. At day 38 the case was moved into the shade.

idiosyncratic derived values rather than fundamental and durable physical measures such as temperature and relative humidity.

The third example of the need for durability in climate data is the concept of 'proofed climate variation', as currently championed by Stefan Michalski. Once something is broken by extreme relative humidity or temperature it will survive unscathed any number of smaller fluctuations without any more damage, unless its vulnerability is reset by conservation treatment. The problem with using this assertion is the scant information about the circumstances which caused the damage we now can see in an object. We need the climate record right back to the birth of the object, and we need to be sure that the object has not been temporarily exposed without recording its local climate. In practice, one would usually use the annual variation of climate in its present location. In other words, there is no point in improving the climatic stability of a museum which has had its collection for a year or two. This is a great relief to the management but though proofed variation is an elegantly simple concept it applies only to mechanical damage: mould, salt efflorescence and metal corrosion will continue if the climate moves into the region of vulnerability, even though a more extreme condition has arisen earlier.

The fourth example of the need for durable data is to demonstrate the effect of global warming on heritage items. There seem to be scant usable data from past measurements, so we must start now to define the 'normal' climate of a historic building, against which to judge future threats, and maintain well calibrated records for a hundred years. For this purpose we need measurements both inside and outside the museum or historic monument. For lack



Figure 5. Estimation of proofed exposure to climate requires the datalogger to be always close to the object it is monitoring. This is particularly true in transport cases, where the climate recorder must be at the same temperature as the object to report true values of the RH at the object.

of these data the English National Trust is reduced to quoting crumbling sea cliffs and flooded lawns as anecdotal evidence for its need for more money to combat the effects of global warming.

The first three examples ideally need dataloggers strapped to the individual items. The fourth requires measurement of the weather also. Apart from the environmental data, one needs an equally meticulous record of the travels of the object from room to room, noting periods out of range of its usual datalogger. I illustrate the adventures that may occur out of sight of the data collection system with an example from the routine operation of an un-named institution, from which I have recently retired. It lends out its treasures, guarded by a loan contract which specifies close limits to display temperature. When the items are returned they are promptly plunged into a cool chamber at -30°C to snuff out insects which may be hitching a ride into the store room. By some contortion of reasoning, an extreme temperature deliberately imposed in a good cause does not risk damage that is feared to arise from a much smaller temperature excursion caused by mere carelessness. Note that this treatment will earn good points from the IPI logger, which will award the cooled object an extra lifetime varying from decades to a single day, according to how long before this event the logger was switched on. The 'proofed climate variation' concept will also comfort the curator by assuring that after the first cycle through the cooler, the object can be re-cooled without further damage.

Truly, conservation is an irrational discipline. But let us set aside such cynical observations and continue on the assumption that environmental records are valuable and must be kept accurate, kept for ever, and ideally be readable for ever.

For quality control of the museum environment it is conventional to measure only temperature and relative humidity. The most potent of all agents of destruction in a well managed museum is light. This is hardly ever measured, because it is so variable within a single enclosure. The photochemical potency of the radiation is never measured. The lux is a convenient and durable standard, being directly related to the SI unit, the candela, but it is only tenuously related, within two orders of magnitude, to the rate of photochemical degradation.[3] The air exchange rate is not measured because it is difficult to measure. Pollutants are getting easier to measure but there are not yet standard plug-in sensors for dataloggers. Sensors for biological activity are also rare. So we measure two variables which, though important, are far from defining all the essential characteristics of the environment. Indoor data alone are useless for diagnosing faults in the building structure, or in the air conditioning apparatus, because the outside weather must be measured and also the rate of exchange with outside air. In theory, the outside weather can be approximated by the nearest official weather station but such data nearly always cost money. There are a few internet data banks for the world's weather but the records are incomplete and intermittent from nearly all sources. It is time consuming to merge data from two sources, each with a different measuring interval and data format.



Figure 6. A silver mirror damaged by exposure to -30°C . Physical damage is difficult to see on less optically perfect objects. The record of the appearance of an object before cooling is seldom detailed enough to convince that no change has occurred.

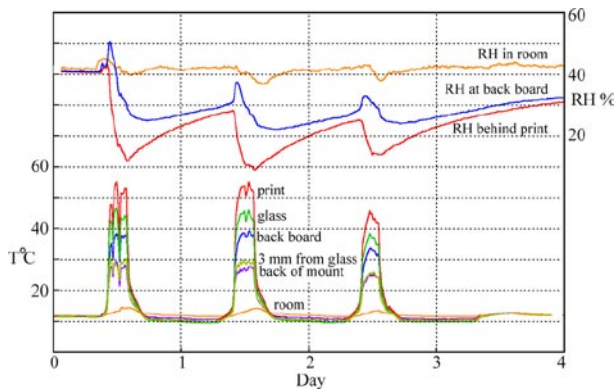

Figure 7. The temperature and RH distributions within a framed print behind glass as it was illuminated by sunlight which had already passed through a window.

A serious study of the microclimate in a building without air conditioning is therefore impossible with our present data stock. Every such campaign must be treated as a research project with its own data collection.

Placing the sensors is not a trivial matter. Even the relatively gentle light in a museum can raise the temperature of an object two degrees, depending on its colour. This will depress the surface RH by six percent. If direct sunlight, even filtered through window glass, reaches the sensor or an object, the temperature can rise by 40°C (figure 7), giving a huge change of local RH, depending on the buffer capacity of the enclosure. The ivory sculpture in the sun in a showcase (figure 3) was exposed to an extreme climate (figure 4) which was captured by a datalogger within the showcase, ivory coloured to give an accurate record of the suffering of the ivory object. This record could not be used to establish a 'proofed climate extreme' because subsequent examination revealed small clean cracks over the object together with dirt filled ancient cracks. However, the resolution of the photographic record of the object was too poor to show either type of crack.

This brings us to the one essential piece of data still missing: the evidence for change of condition of the object. This should be recorded together with the environmental record, but hardly ever is. The National Gallery, London, pioneered the real time study of colour fading. Few institutions are prepared to support such slowly unfolding projects, but many institutions are insistent on storing partial environment data that has little likelihood of providing valuable insight over the long term. There have been attempts to develop surrogate sensitive objects to set out in museum galleries, for example the tempera paint strips developed by Marianne

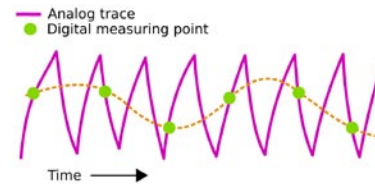

Figure 8. A datalogger which makes intermittent measurements can generate a completely different cyclic pattern of temperature and RH than that actually produced by the air conditioning.

Odlyha [4], but the rapid early changes measured in these strips seems to be a maturing process which is much faster than the rate of decay of tempera in centuries old paintings. Metal tokens are also available; their corrosion is measured by electrical resistance change or by weight change measured through vibration frequency. Such measurements are not yet commonly integrated with the collection of climate data.

DATA AS A SERIES OF POINT MEASUREMENTS

The thermohygrograph is an analog instrument which registers all the time, with a certain lag in response. Digital data loggers wake up at intervals to make a measurement. They can be set to measure once per hour, or once every minute, memorising the average every hour, or many other combinations of intervals. Intermittent measurement prolongs battery life but is vulnerable to a phenomenon called 'aliasing'. This is illustrated in figure 8. It is not important in naturally ventilated rooms but can cause misinterpretation of air conditioning, which usually generates a cyclically varying climate which can interact with the measuring cycle of the logger to register a spurious beat frequency cycle.

CALIBRATION OF SENSORS

Calibration of temperature sensors is very rarely done because even the cheapest sensors, thermistors, have become reliable. However, the sensor signal is subjected to electronic processing that may itself be temperature sensitive. Temperature compensation is quite a subtle design challenge in electronics, which cannot be assumed for data loggers operating far from room temperature. Cheap data loggers are also sensitive to battery voltage. In reality, we have no idea of the accuracy of temperature records.

A year is a long time in the life of a relative humidity sensor. Most survive only until they suffer a moment of condensation. There are long lasting RH sensors but many loggers use unstable sensors. In situ calibration of both temperature and RH is

best done with a psychrometer. This instrument has the advantage of depending on two temperature sensors, which are inherently reliable and whose identical readings can be checked. Furthermore, the RH signal is in the form of a temperature difference. However, its accuracy depends on how it is used. The conventional wisdom is that distilled water must be used but that is a simplified specification of the purity required. There must be no long chain alcohols or other film forming chemicals from sweat, which reduce the evaporation rate of water. These cause a greater error than using tapwater. Another largely ignored source of error is radiative heating from the body of the operator when using the sling psychrometer in a cold place. This can easily cause a five percent error in RH. This error can be avoided by using a clockwork or electrically aspirated psychrometer which has shielded temperature sensors.

The other commonly used RH calibrator is a saturated salt solution, sometimes encapsulated so only water vapour passes through a semi-permeable membrane. The problem with these devices is that for calibrating at a RH point below the ambient RH, the salt solution will be absorbing water vapour and thus diluting the surface solution. Diffusion of ions to equalise the concentration is very slow in unstirred solutions, so too high a RH is generated. This calibration method only works for high RH points above ambient, where the calibrating solution is losing water vapour. One can stir the solution, but this heats it up, thus increasing the water vapour



Figure 9. The psychrometer is suitable for in situ calibration, if the wick is free of film forming chemicals and radiant heating of the wet sensor is prevented. There are also transportable dew point sensors, which don't need wetting.



Figure 10. Data loggers have a valuable role to play in persuading the museum authorities not to be satisfied with bad storage rooms just because they are cheap.

pressure at the surface and increasing the RH at the cooler surface of the sensor. Lack of temperature uniformity is a frequent cause of error when using saturated salt solutions for calibration. A one degree celsius difference in temperature between calibrating device and the datalogger causes about a 3% error in RH. Few conservation departments have constant temperature cabinets for equilibrating the sensor with its calibrating aqueous solution. Calibrating RH sensors is difficult even in the laboratory and is inaccurate when done in situ.

STORING THE DATA

There are several specialised scientific groups which have established highly effective and durable databases. Notably x-ray diffraction patterns and infra red spectra are available in standard formats and are well maintained by central organisations. Every one of these spectra is useful - each describes a chemical compound or crystal. Climate data are much more diffuse, much less universal in their usefulness and only occasionally throw up diagnostically helpful events, or dramatic failures of environmental control. The signal to noise ratio is thus very small, so it is unlikely that an idealistic group of people will gather their energies to establish a data bank. One must assume that environmental records will be stored locally in the institution, for routine measurements. For investigative use of dataloggers, one must hope that developments in scientific digital publishing will allow verbose experimental data to be stored together with the compact, readable article, and thus be available to sceptical readers wishing to re-examine the evidence.

file as a conventional calendar date in plain text, rather than a single number, as used for internal calculations in spreadsheets. However, the text calendar also has confused conventions. The first twelve days of the month are ambiguous because the US puts month before day, then year, while everyone else uses the day-month-year convention. The ISO date format solves this very neatly by using the logical sequence year-month-day-hour-minute-second. the ISO format for hour 16, minute 46 of the seventh of May 2007 is: 20070507T16:46:00. Dates formulated in this way sort well, and data sets can easily be merged, because the most significant unit comes first, as in normal numbers. However, nobody uses the ISO date format. Excel cannot export it, though it can read it. The unreflective decisions of individual programmers and the conservatism of users have often prevailed over the wise deliberations of expert committees.

PHYSICAL STORAGE OF CLIMATE DATA

Even if the format is durable, the storage medium is not. Optical storage media have a predicted durability of decades, compared with hundreds of years for neutral paper. And paper's durability is not a predicted value, it is based on experience.

CONCLUSIONS

We currently store only a subset of the information needed to connect environmental influences with observed degradation of materials. Only very seldom is the measuring device sufficiently close to the object for it to constitute a definitive record for that object. The data are stored in a variety of formats with no convention about what format to use for data storage and interchange. This situation is entirely adequate to ensure quality control of the environment during exhibition and transport but it is unlikely that data will be retained long enough, and the measured variables be comprehensive enough, or close enough to the object, for scientific study of the effect of environment on materials over many years. One has to conclude that routinely collected environmental data is unlikely to yield interesting information to future enquiries.

AUTHOR

Tim Padfield,
May Cottage, Old Road, Harbertonford,
Totnes TQ9 7TA, UK
tim@padfield.dk

REFERENCES

- 1 <http://www.imagepermanenceinstitute.org/>
- 2 The physical chemistry underpinning the preservation index is explained at:
http://www.padfield.org/tim/cfys/twpi/twpi_01.php
- 3 <http://www.padfield.org/tim/cfys/lightmtr/luxerror.php>
- 4 M.Odlyha, N.S.Cohen and G.M.Foster
"Dosimetry of paintings : determination of the degree of chemical change in museum exposed test paintings (smalt tempera) by thermal analysis" *Thermochemica Acta* 365 (2000)35-44.
- 5 <http://decimaltime.hynes.net/dates.html>



This work is licensed under a Creative Commons Attribution - Noncommercial - No Derivative Works 3.0 Licence.

Session 4

Use of enclosure to control climate
- the larger environment

CLIMATE CONTROL IN DANISH CHURCHES

POUL KLENZ LARSEN

ABSTRACT

The climate control in Danish churches is a compromise between the demand for human comfort and the need for preservation. Most medieval churches are heated in winter and left unheated in summer. The consequence of this heating practice is large variations in the relative humidity. To control the relative humidity within reasonable limits, the churches should be heated all year, and the temperature should be adjusted to an annual cycle. A moderate relative humidity can also be achieved by mechanical dehumidification, but the effect will sometimes be spoiled by evaporation of water vapour from an internal source. Some churches have the ability to humidify the indoor climate by capillary migration of moisture through the structure. Such processes must be accounted for when devising the heating strategy for a particular church. Further investigation is needed to locate the source of the passive humidification. The conflicting interests of congregation and conservation can sometimes be solved with transparent walls or glass doors to define specific climate zones with independent climate control.

INTRODUCTION

Danish medieval churches contain a variety of polychrome wooden sculpture and wall paintings. Many items have survived centuries of neglect due to natural disasters, epidemic diseases or religious changes, so it seems to be a fairly safe place for valuable pieces of religious art. In our days, the main worry is not warfare or the plague. A risk assessment analysis would identify the indoor climate as the main threat to the preservation of these objects. Conventional museum and archive set points for temperature and relative humidity are not much help when specifying the appropriate climate for Danish churches. The history and the condition of the objects must be taken into consideration when proposing a climate strategy for each individual church. The problems arise from the fundamental fact that the priest is sensitive to temperature, whereas the altarpiece responds mainly to the relative humidity. Wall paintings are susceptible to damage by precipitation of salts, which depends on variations in both temperature and relative humidity. The organs go out of tune and the organist catches



Figure 1. Climate control in Danish churches is a compromise between conflicting interests and sometimes calls for unconventional solutions.

a cold if the temperature is not constant. Heating has a major influence on the relative humidity, so the demand for thermal comfort does not provide healthy conditions for preservation. It is a delicate job to devise heating strategies that will satisfy both conservation and congregation. This paper presents a summary of the considerations reported by other authors followed by a few case studies where unconventional solutions are tested, as a compromise between the conflicting interests.

BACKGROUND

The first permanent heating installations in Danish churches were stoves of cast iron. We don't have any climate records from those days, but the soot was a problem for the conservation of wall paintings. Central heating systems were introduced from the beginning of the 20th century, providing a much cleaner and drier indoor environment. Warm air systems were preferred for village churches heated intermittently. The advantage was a fast rise of temperature, but they were less suited for tall rooms.



Figure 2. Detail of the altarpiece in Sct. Olai Church in Helsingør. The paint has cracked and partly delaminated due to variations in relative humidity caused by constant heating. Photo by Roberto Fortuna, the National Museum of Denmark.

Most of the heat concentrated below the ceiling, where only the angels would benefit, and left the humans cold at floor level. Lund Madsen [1] used a thermal mannequin to measure the influence of different heating systems on the thermal experience. Electric radiant heating panels mounted under the bench seats provided the best thermal comfort at a moderate air temperature. This work led to the design of a pew with integrated heating foils at the back and under the seat.

Camuffo [2] introduced the Friendly Heating concept, which involved a novel pew design with radiant heating elements mounted under the seat, at the back and below the kneeling rail. A detailed study was conducted by Limpens-Neilen [3] with focus on the convective air movements in the pew and the consequence for thermal comfort. It is possible to heat the person without heating the building, but there is a limit to how much radiant heat a person can endure in a cold building and still be comfortable. The main drawback for all kinds of pew heating is that it only heats up the congregation. The chancel and other adjacent spaces must be heated by conventional heating systems.

Korsgaard [4] established the heating regulation for Danish churches and defined two climatic categories for churches: the permanently heated and the intermittently heated. The larger urban churches with frequent services belong to the first category, for which the basic temperature should be no more than 15°C in winter. The small village churches with only a Sunday service make up the

second category, where 8°C is the set point for the basic temperature. The threshold values are chosen as a compromise between the need to save energy and the need for human comfort. In both categories the maximum temperature for services is 18°C, which should be reached within 6 hours starting from the basic temperature. The demand for rapid heating was a precaution suggested by Künzle and Holz [5] to protect wooden objects. If the rise and fall in temperature were fast, the objects would not feel the change in RH before it was over. Several later authors have disproved this assumption. For both climate categories, the regulation states that the relative humidity should be between 50% and 80% all year round. These rather broad limits are a compromise to reduce biological activity and to prevent mechanical damage caused by drying shrinkage.

Mecklenburg et al. [6] proposed the interval 40% - 70% RH to be safe for most wood species, glues, paints and grounds, but the interval was much reduced if the object had equilibrated to a higher RH. Their investigations did not give any information regarding the influence of time on the stress induced by changes in the RH. Bratasz & Koslowski [7] reported a rapid response to changing RH of the shrinkage of wooden objects. According to their measurements on polychrome wooden sculpture in situ in Eglise Rocco del Pietro, even diurnal variations affect the surface layers and lead to cracking. Their work was only concerned with the mechanical damage to the wood itself, but the



Figure 3. Detail of the wall paintings in Rorby church near Kalundborg. The paintings deteriorated by the precipitation of salts due to diurnal fluctuations in the relative humidity caused by intermittent heating. Photo by Roberto Fortuna, the National Museum of Denmark.

paint layers on the surface are the more vulnerable. Olstad, Haugen and Nilsen [8] investigated the effect of climate variations on test specimens of polychrome wood in a micro scale. They found that small and rapid changes in both RH and temperature caused damage and proposed a maximum change of 10% RH to be safe. The influence of short heating events required by the Danish heating regulations remains a subject for further investigations.

Wall painting is an integrated part of the building and will therefore experience a different climate than the objects within the church, because of the temperature gradient between the wall surface and the room. A study by Padfield et. al. [9] in Gundsømagle Church showed that the influence of intermittent heating was reduced significantly because of the thermal inertia of the limestone walls, so the RH at the surface remained almost constant. But the falling RH in the church caused evaporation of water vapour from the surface. Investigations in Tirsted Church by Klenz Larsen [10] indicated that a perpetual moisture migration towards the inside surface is a hazard to wall paintings, because salts accumulate at the surface. The paintings in the chancel suffered severe salt damage because of permanent low RH in the winter, caused by the heating. A further complication was the composition of the salt contamination in the plaster. Salt would precipitate from solution at any RH in the range 30% to 70 %, which coincided with the natural climatic variation in the church. Recent work by Sawdy & Heritage [11] concludes that salt mixtures are more sensitive to fast and large variations in RH than to slow and small variations. This result is supported by a study by Klenz Larsen [12] of wall paintings located in the vaults in Fanefjord church. The drop in RH caused by diurnal heating episodes led to the precipitation of salt at the surface and the deterioration of the paintings. A similar situation was studied in Rørby church [13], where a climate chamber was built to protect the vault against climate variations; it prevented salt deterioration. The safe RH-range for salt contaminated wall paintings depends on the salt species and should be defined in each individual case.

The geometry of the interior, the structure and materials of the building should be taken into consideration. Unlike most modern buildings, the churches have great thermal inertia, which will level out diurnal variations in temperature. The few and small windows allow little solar heating in summer but also reduce heat loss in winter. The natural stability of the relative humidity depends on the ventilation rate and may be overruled by

too much infiltration of outside air. Brostrøm [14] developed a mathematical model for the hygrothermal behaviour of a stone church. The model would enable calculation of the heating power and the heating time required, when designing a new heating installation. Brostrøm also suggested various models for calculating the influence on the indoor RH from water vapour evaporating from the walls. Studies by Schellen [15] have demonstrated good agreement between computer simulations and measurements in Dutch churches. The question is, can computer programs designed for modelling indoor climate in modern buildings be relied upon to predict the consequence of preventive interventions in medieval churches.

CASE STUDIES

The Gothic cathedral of Sct. Olai in Helsingør is a large brick masonry structure with a magnificent baroque altarpiece. The last restoration was undertaken in 1967, but 30 year later the gilding and paint was cracking and peeling. It was essential to improve the climatic conditions in the church, which was at that time permanently heated by a central heating system with large cast iron radiators. The temperature was around 20°C all year round, and the RH drifted from 80% in summer to 20% in winter. This variation is a natural consequence of the annual fluctuation in the water vapour content of the outside air. If the ventilation rate is large, and the internal moisture supply is small, the indoor water vapour concentration (the absolute humidity) will be the same as outside. To reduce the drying in winter, the average temperature should not be more than 15°C. But this was not acceptable, partly because of cold draughts below the large windows and in the central nave. Floor heating was established to maintain thermal comfort at a reduced temperature. The large windows had double glazing installed to prevent convective air movements and to reduce the natural ventilation. This intervention

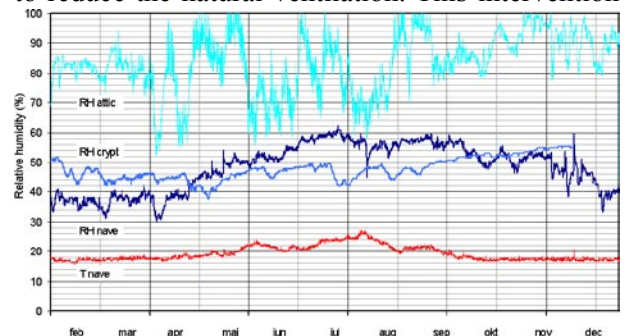

Figure 4. Climate records from Sct. Olai Church in Helsingør in 2003. The climate was measured in the nave, the crypt and the attic. The temperature in the attic and in the crypt is not displayed.



Figure 5. Detail of the windows in Sct. Olai church. The framing for the double glazing was custom designed to fit the original leaded windows. Photo by Poul Klens Larsen

is usually not allowed for architectural reason, so a custom designed frame was fitted inside the original windows. These changes have improved the climate in the church, so the annual average variation in RH is limited to 30%-60% with little diurnal fluctuation. An unexpected complication occurred during construction work, when numerous crypts with wooden coffins were found below the old floor. The mummified bodies wearing fine clothes were in quite good condition, so their microclimate had been congenial for centuries. We were worried about how the new floor heating would influence

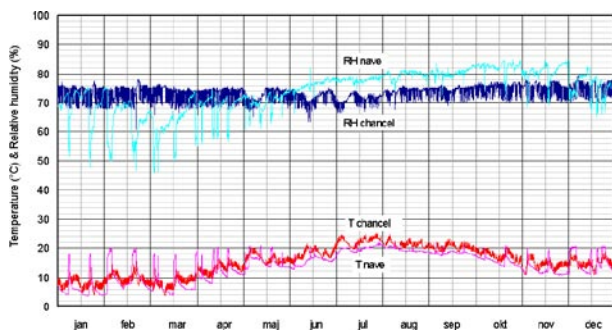

Figure 6. Climate records from the nave and the chancel in Dybe Church on the west coast of Jutland. The RH in the nave is regulated by hygrostat controlled heating.

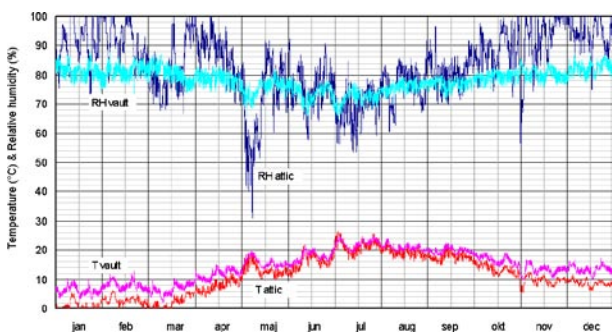

Figure 7. Climate records from the attic and the vault surface in Dybe Church. The RH at the surface of the chancel vault is not as constant as in the chancel itself, because the surface temperature is influenced by the temperature variations in the attic.

their preservation, and arranged a series of vertical pipes installed in the concrete slab. The pipes would allow monitoring and eventually ventilation if necessary. However, it was reassuring to learn that the climate below the floor was much more stable than above, with an annual drift in RH from 40% to 55%. No doubt the golden altarpiece would have been better preserved in an underground dungeon. The attic, on the other hand, would be a bad place to store wooden objects, because the RH is too high and too unstable.

Dybe church is located at the west coast of Jutland, close to the North Sea, where the natural airborne deposition of sea salt is large. The decoration of the chancel vault suffered severe damage due to sodium chloride, which may have been brought in as aerosol from the nearby sea during the church's 800 year lifetime. For centuries the salt had remained in solution due to a permanent high relative humidity in the unheated building. But when a new electric heating system was installed, the deterioration of the wall paintings progressed rapidly. The heating caused the RH to drop below 75% in the winter, so the salt would precipitate and disrupt the paintings in the vault. The salt contamination of the individual bricks was too severe to be treated from the surface.



Figure 8. View through the glass door in the chancel arch in Dybe church. The lime painting in the vault is visible in the chancel. The heating elements on the wall below the vault are controlled by a hygrostat to keep the RH at 70-80% all year. Photo by Roberto Fortuna, the National Museum of Denmark.



Figure 9. View through the transparent wall into the chapel in Ølsemagle church. Fragments of the wall paintings are visible on the wall and in the vault. The chancel is unheated, so a cool and humid climate is maintained all year, except for special occasions when the glass door is opened. Photo by Roberto Fortuna, the National Museum of Denmark.

It was decided to restore the paintings and prevent further decay by climate control. A glass door was installed to separate the chancel from the nave. The door would remain closed at all times, except for the services, when it was opened for one hour. The climate in the chancel was regulated with the help of a hygostat, turning on a little heat to keep the RH in the range 70% - 80%. One should be aware that the RH measured inside the chancel is not the same as the climate at the surface of the vault. In winter the RH is higher at the surface because the temperature is slightly lower, but in summer the RH is a little lower because the attic is heated by sun radiation. But the RH is still much more stable than in the nave, which is heated at irregular intervals over the winter. This simple installation has now worked for 3 years and no damage has been observed.

A similar solution was adapted for Ølsemagle church in Zealand. The congregation wanted to use a former chapel on the north side of the nave for extra seats on special occasions. The extension had been used as a tool shed for many years, unheated, with a stable but humid indoor climate all year. The walls and the vault had well preserved fragments of wall paintings, which would possibly deteriorate in a warmer and dryer indoor environment. There are many reports about lime paintings suddenly flaking due to a change in the heating practice. In some cases the installation of new heating systems has even led to the rediscovery of wall paintings which had been covered for centuries by thick layers of lime wash. The paintings were revealed because the lime wash lost adhesion when the structure dried

out due to the improvement in heating capacity. The conservator demanded as little change in the climate as possible, so a transparent glass wall was installed in the arch, with a door to open for the Christmas ceremony. On ordinary days the chapel is not accessible. No heating was installed, but the heat transmission from the nave keeps a slightly higher temperature than before, with an average RH at 80%.

The small village church in Karlslunde south of Copenhagen has a Romanesque nave and apse made of a soft limestone. The main attraction is a baroque altarpiece, which had suffered severe damage due to drying shrinkage. After conservation, the congregation had a dehumidifier permanently installed to keep a constant indoor RH all year round. The altarpiece itself had been equilibrated to 50% RH during a prolonged visit to the conservation workshop. The climate records showed that the RH in the church was around 50% all year. In summer the indoor air was drier than the outside air, due to the influence of the dehumidifier. But in winter, the inside air was more humid than outside, even though the dehumidifier was still running. A permanent surplus of water vapour in the air can only be maintained by a powerful water source, which was most likely to be the outer walls. The local porous limestone is well known for the ability to absorb rain and dew on the outside and conduct the liquid moisture through the structure. The moisture is released to the inside by evaporation at a constant



Figure 10. Diagram illustrating the climate control in Karlslunde church. In summer, water vapour is supplied from the outside air through natural ventilation. In winter, water vapour is probably released from the building structure by evaporation. The dehumidifier removes moisture from the interior all year and maintains a constant RH independently of temperature.

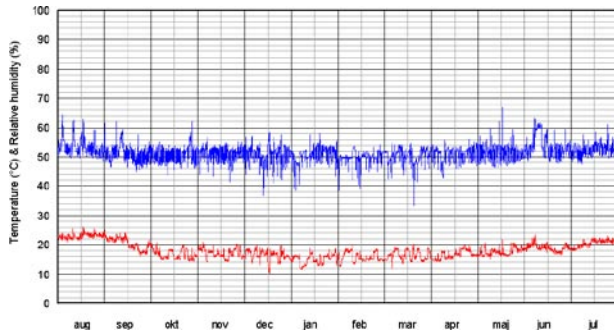

Figure 11. Climate records from Karlslunde church south of Copenhagen. The RH is controlled to 45-55% all year by a mechanical dehumidifier, except for a few episodes, when the RH suddenly jumped to 60% due to a malfunction.

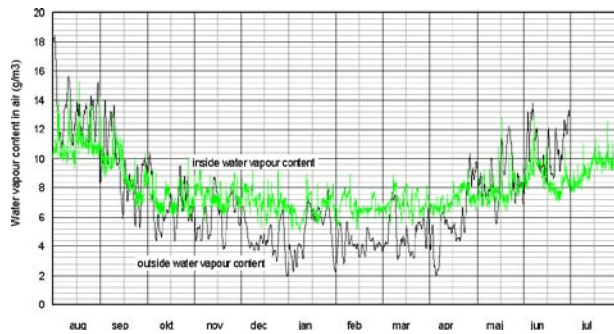

Figure 12. The content of water vapour in the air inside and outside calculated from the climate records in Karlslunde church. In summer the air is drier inside than outside due to the dehumidifier; but in winter the inside air is more humid than outside, in spite of the dehumidification. There is an internal source of moisture, possibly the limestone walls acting as passive humidifiers.



Figure 13. Climate records from Ollerup church, located on Fyn. The temperature is adjusted stepwise to a new set point for each month. The church is heated to 18°C for services.

rate, due to the permanent gradient in RH. Thus the indoor climate in Karlslunde is a state of equilibrium between the constant injection of humidity from the walls and the removal of water by the machinery. It is a benefit for the preservation of the altarpiece, but it may be a damaging preventive measure in the long run, if salts accumulate at the interior surface of the wall.

Ollerup Church is a brick masonry structure located in a village on Fyn. The congregation was worried about the condition of the organ, which played out

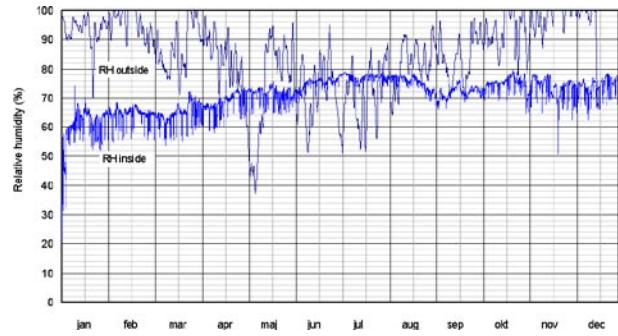

Figure 14. Climate records from Ollerup church. The relative humidity is within the range 60-80%RH, except for the brief episodes of heating for Sunday services, where the RH drops below 60%.

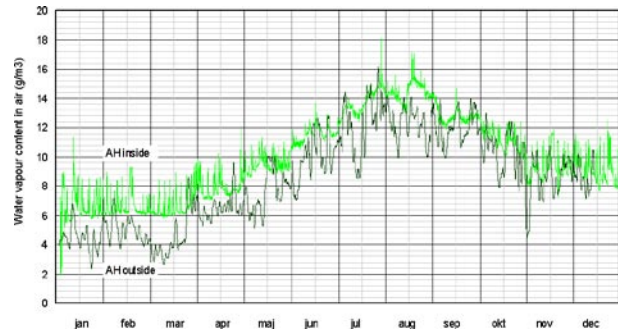

Figure 15. The content of water vapour in the air inside and outside, calculated from the climate records in Ollerup church. Most of the year the inside air is more humid than the outside air. This seems to be a consequence of the permanent heating. There is an internal source of moisture, possibly the brick masonry walls acting as passive humidifiers.

of tune because of climate variations. The church was intermittently heated in winter by electric panels mounted below the bench seats. The heat was turned off over the summer, and the heating by solar radiation was small, so the temperature would never exceed 18°C. This is a general problem for many village churches with narrow windows and a ventilated attic. A new heating strategy was proposed for the church to be heated all year to a variable set point ranging from 10°C in winter to 22°C in summer. The set point was adjusted stepwise to a fixed temperature every month. At first the congregation was reluctant to allow heating in summer, because this was not required for human comfort. But the summer heating keeps the RH below 80% even on the most humid days, so the variations in RH are within 60-80% all year. There are some occasions during the winter when additional heating to 18°C for services brings the RH further down, but not as much as expected. Every heating event shows a simultaneous rise in absolute humidity of approximately 2 g/m³. The absolute humidity quickly falls back to the natural level, which is also more humid than outside for most of the year. In February, the surplus

of water vapour is largest, but even in summer there are episodes with considerable moisture surplus. There seems to be a constant moisture migration to the inside, driven by the heating. The concept of controlling RH by adjusting the temperature should be used with care, because it may result in considerable moisture migration.

CONCLUSIONS

The main challenge for climate control in Danish churches is not to design advanced heating systems but to devise the appropriate heating practice. Too much heating in the winter or too little heating in the summer causes the trouble. Most medieval churches have small windows and thick massive walls, which allows little solar heating of the interior. The summer indoor climate is therefore chilly and humid, with RH above 80% for several months. The damp environment facilitates mould growth, and pests are encouraged to breed and feed on any organic substance. The polychrome wooden objects suffer damage from drying shrinkage during the winter, when the RH is reduced due to the heating. Wall paintings are susceptible to salt decay, because the most common salts will dissolve and precipitate as the RH varies in the range 30-80 %. Recent investigations suggest the annual and diurnal change in RH should be less than 10%RH to protect the paint on wooden artwork and wall paintings.

There are two ways of moderating the RH in Danish churches. One way is to control the water vapour content in the air and another way is to adjust the air temperature to an annual cycle. The first principle involves the use of a mechanical dehumidifier. This apparatus will be able to control the RH within a reasonable interval over the year. Most churches will only need dehumidification a few months over the summer to prevent the RH from getting too high. Even so, many architects and conservators have an intuitive aversion to dehumidifiers. There is a fear of drying damage due to malfunction, and uncertainty about the long term effect of lowering the RH. As shown in the Karlslunde case, there is certainly a risk of accelerating salt migration because of the perpetual passive humidification by the building structure.

The RH can be controlled by temperature regulation, either by a hygrostat or by adjusting the temperature set point according to the average outdoor temperature. The hygrostat gives a fairly constant RH, because there is a fast response to sudden changes in the outdoor climate. Fixed temperature set

points cannot give better control than 10% RH over the day, which may be harmful to sensitive objects or salt contaminated wall paintings. In some churches the moisture content of the inside air will be higher than outside because the building structure releases moisture. If the windows remain single glazed, which is the case in most churches, there will be long lasting episodes of condensation in the winter. The dew may lead to corrosion of the metal window frame. The condensation is best avoided by double glazing, which is usually not allowed for aesthetic reasons.

In some churches the climate records indicate a higher water vapour content inside than outside. The high humidity level is not a consequence of conventional humidity buffer effects, because this always requires episodes of moisture deficit to be levelled out by episodes of moisture surplus. A permanent water vapour surplus can only be maintained by a constant source of moisture. It appears to be the masonry walls, acting as passive humidifiers and influencing the indoor climate by a constant evaporation. Such constant flow of moisture can eventually lead to salt accumulation on the inside of the walls or vault. Further investigation is needed to locate the source of the passive humidification.

AUTHOR

Poul Klens Larsen
The National Museum of Denmark
Department of Conservation
IC Modewegsvej, Brede,
DK-2800 Kgs. Lyngby
poul.klens.larsen@natmus.dk

REFERENCES

- 1 Madsen, Thomas Lund & Nørgaard, Jens (1986), "Kirkevarmeanlæg. Varmeforbrug og indeklima ved diskontinuert opvarmning af store rum". LfV, meddelelse nr. 181. Danmarks Tekniske Højskole. (summary in English).
- 2 Camuffo, Dario et. al. (2006), "A practical guide to the pros and cons of various heating systems with a view to the conservation of the cultural heritage in churches. Results of the European project Friendly Heating (EVK4-CT-2001-00067).
- 3 Limpens-Neilen, Dionne (2006), "Bench Heating in monumental churches". Ph.D thesis, Technische Universiteit Eindhoven.

- 4 Korsgård, Vagn. (1993), „Cirkulæreskrivelse om vejledning vedrørende udførelse og brug af kirkevarmeanlæg m.v.“. Kirkeministeriet (Danish ministry of church affairs).
- 5 Künzel, H. & Holz, D. (1991), “Bauphysikalische Untersuchungen in unbeheizten und beheizten Gebäuden alter Bauart“. Bericht FB-32/1991. Fraunhofer Institut für Bauphysik.
- 6 Mecklenburg, Marion F., Tumosa, Charles S., Erhardt, David (1998), „Structural Response of Painted Wood Surfaces to Changes in Ambient Relative Humidity“. Painted Wood, History and Conservation, pp 464-483. The Getty Conservation Institute.
- 7 Bratasz, Lucasz., Kozlowski, Roman., (2005) „Laser sensors for continuous in-situ monitoring of the dimensional response of wooden objects“. Studies in Conservation 50, pp. 1-10.
- 8 Olstad, Tone., Haugen, Annika., Nilsen Tom-Nils (2001) Polychrome wooden ecclesiastical art – climate and dimensional changes. Norsk institutt for kulturminneforskning NIKU publications 110.
- 9 Padfield, Tim., Bøllingtoft, Peder., Eshøj, Bent., Christensen., Mads Chr. (1993): ”The wall paintings of Gundsømagle Church, Denmark”. Preventive conservation, theory, practice and research. Preprints for the IIC Congress in Ottawa, pp. 90-98.
- 10 Klenz Larsen, Poul (2002): ”Moisture measurements in Tirsted Church”. Journal of Architectural Conservation, no. 1, vol 10, march 2004, pp 22-35
- 11 Sawdy, A & Heritage, A (2007): “Evaluating the influence of mixture composition on the kinetics of salt damage in wall paintings using time lapse video imaging with direct data annotation”. Environmental Geology, vol 52 pp. 303 – 315.
- 12 Klenz Larsen, Poul (1999), ”Salt damage to the medieval plaster on a vault in Fanefjord Church“. Proceedings of the International RILEM Workshop: Historic Mortars: Characteristics and Tests, pp 43 – 50. Paisley University, Scotland 12.- 14. May 1999. Edited by P. Bartos et. al.
- 13 Klenz Larsen, Poul (2002), “The use of passive climate control to prevent salt decay in Rørby church”. The Study of Salt Deterioration Mechanisms. Decay of Brick Walls influenced by interior Climate Changes, pp. 102-107. European Heritage Laboratories – Raphaël Project 1999
- 14 Brostrøm, Tor (1996), “Uppvärmning i kyrker. Fugt- och värmtekniska beräkningar för dimensionering och klimatstyrning.” Doktorsavhandling, Kungliga Tekniska Högskolan.
- 15 Schellen, Henk L. (2002), ”Heating Monumental Churches, Indoor climate and preservation of Cultural Heritage”. Ph.D. thesis. Eindhoven University of Technology. ISBN: 90-386-1556-6.



This work is licensed under a Creative Commons Attribution - Noncommercial - No Derivative Works 3.0 Licence.

MANAGING EXTERNAL ENVIRONMENTS THROUGH PREVENTIVE CONSERVATION: THE INVESTIGATION AND CONTROL OF ENVIRONMENTALLY-CAUSED DETERIORATION OF DECORATIVE SURFACES IN THE MARLBOROUGH PAVILION, CHARTWELL, KENT

KATY LITHGOW, TOBIT CURTEIS AND LINDA BULLOCK

ABSTRACT

The Marlborough Pavilion is a small stone building located in the garden of Chartwell, Sir Winston Churchill's country house in Kent. Open on two sides, the Pavilion's current decorations have deteriorated since their execution in 1934 and restorations in 1949, 1981 and 1989. As the last restoration was conducted under the original artist's supervision, it has historic significance, and therefore research was undertaken by the National Trust to investigate the causes of its deterioration, design ways of reducing the rate of damage, and assess the costs and benefits of conservation and restoration. Environmental surveys demonstrated that damage was caused by both the adverse microclimate (condensation) and the penetration of liquid water, the latter successfully addressed by building repairs. Several approaches to controlling the microclimate were tested during winter months, when the deterioration was most active, and the results were monitored. The most successful system involved the use of a temporary modular enclosure with a high level of hygral and thermal buffering, used in conjunction with a mechanical dehumidifier. By using this system in the winter, instances of high and unstable relative



Figure 1. External view of the Marlborough Pavilion from the south



Figure 2. View of the Pavilion's interior before treatment

humidity and condensation were prevented, and the rate of deterioration was significantly reduced. The costs were no greater than restoration and had the benefit of maintaining the historic significance of the original decorative scheme.

INTRODUCTION AND BACKGROUND TO THE PROJECT

Located in the gardens of Chartwell, Sir Winston Churchill's country house in Kent, the small summerhouse known as the Marlborough Pavilion was built in the mid 1920s of clunch and dressed sandstone, with a lead roof. [1] (Figure 1). Open on two sides, the internal walls are rendered and painted, and embellished with slate and terracotta wall plaques, concrete figurative busts and a low relief painted slate frieze. The building was originally decorated in 1934 by John Spencer Churchill (1909-1992), Sir Winston's nephew, and again in 1949 as a 75th birthday gift for his uncle [2]. The scheme commemorates John Churchill, the first Duke of Marlborough, and victor of the Battle of Blenheim. The house and its gardens were donated to the National Trust in 1946 and occupied by Sir Winston and Lady Churchill in their lifetimes. (Figure 2)

Due principally to the semi-open construction of the Pavilion, the internal surfaces have deteriorated ever since they were executed. After wartime neglect, the 1934 scheme was restored 'in a different and more durable medium' by the artist himself in 1949 [3] and repainted in 1981 by the decorator Owen Turville who worked on all the walls, ceiling and the slate frieze under John Spencer Churchill's direct instruction [4]. The ceiling was repainted in 1989.[5] By 1997 the decorative surfaces had deteriorated again through algal growth, erosion by water, cracking, flaking and loss of the paint layer. Between 1998 and 2005 the National Trust researched the causes of deterioration, to design measures to control the damage and to devise a long term conservation strategy for the polychrome decoration. The project involved complex decisions, balancing the significance of the decoration and its difficult location with the costs and benefits of both a conservation and a restoration approach.

SIGNIFICANCE

The Pavilion's decoration history showed that the present painted scheme has significance as a first-generation descendant of the 1949 scheme, executed under the original artist's eye.

The 'durable medium' meant using slate as a support and casein as a paint medium. John Spencer Churchill's colour samples and annotated photographs recording the 1949 scheme survive at Chartwell and suggest its tone was more solid and glossy than the washed out pastel colours currently seen. However, according to Owen Turville, by 1981 John Spencer Churchill intended that:

'the paintwork should have a weathered or distressed look and indeed he specified that the paint should be applied and then wiped back. Owen used more of a dragged wash technique in Casein Tempura [sic] and finished it on the slate in white wax. Apparently GSC [sic] saw the completed restoration and said that it was exactly right.' [6]

It was felt that this authenticity would be compromised and eventually destroyed by repeated restoration. Preserving the Pavilion's 'spirit of place' meant retaining the building's open sides so that it can function as a summerhouse and enable visitors, for whose benefit the Trust preserves the property, to enjoy the space as it was used by Sir Winston. However, it also meant that the polychrome decoration would continue to deteriorate because of exposure to the weather, requiring periodic conservation and restoration.



Figure 3. Detail of microbiological growth on the slate frieze

WORKING WITH CHANGE

In common with other conservation bodies, the National Trust accepts that change is inevitable and should be worked with according to the nature of the change and the threat it poses to the material to be preserved. In the field of cultural heritage, change such as increased visitor numbers, can be accommodated by managing visitor flow, or adapted to, by enhancing physical protection. Destructive change can be mitigated by recording cultural material before the change occurs, or by relocating it, for example where cliff top buildings are threatened by coastal erosion. Ultimately, change can be prevented or opposed where there is an adverse and avoidable impact, for example by challenging planning proposals. Thus the Trust aims to understand and preserve significance as much as material evidence, and defines conservation as:

'...the careful management of change. It is about revealing and sharing the significance of places and ensuring that their special qualities are protected, enhanced, understood and enjoyed by present and future generations'. [7]

Working with change in the Marlborough Pavilion meant minimising the rate of change. The project aimed to assess whether the speed of deterioration could be reduced to increase the periods between interventions beyond the 10 year cycles suggested by recent treatment history, prolonging the life of authentic decoration as long as possible.

ENVIRONMENTAL INVESTIGATIONS

An assessment of the condition of the building envelope in the 1990s identified failures in the roof which put at risk the internal decorative surfaces. repairs were undertaken on the roof between 1995 and 1996 directed by the architects Purcell Miller

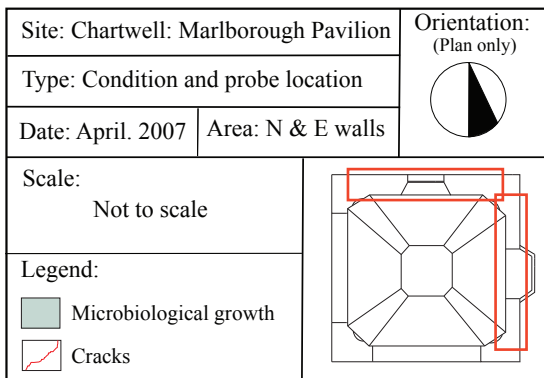
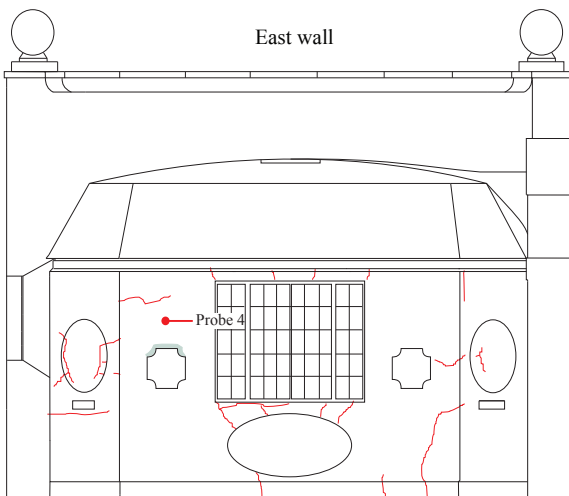
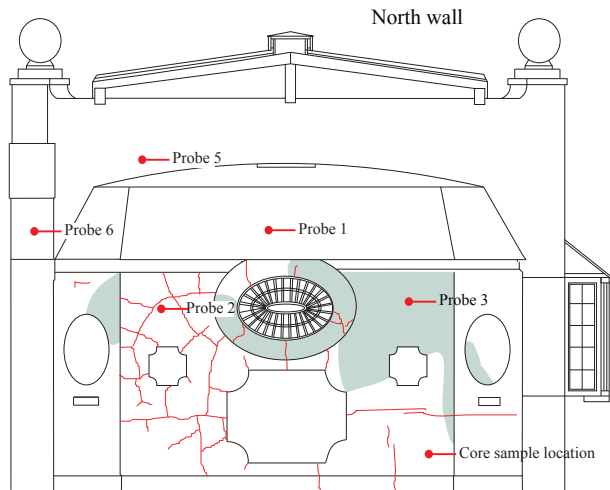

Figure 4. Plan and elevations with the patterns of damage and the location of the monitoring probes and core sample

Tritton.[8] A meeting between Conservation Advisers and property management staff in 1997 identified an overall approach and a range of conservation actions. [9]

In 1998, a survey of the condition of the polychromy, undertaken by The Wallpaintings Workshop, identified patterns of deterioration consistent with environmental factors. Limited remedial treatment

was undertaken to prevent further short term loss and improve the decoration's appearance.

A study of the environmental conditions affecting the building, in order to identify factors causing active deterioration to the decorative surfaces and to develop strategies for their control, was subsequently carried out by Tobit Curteis Associates.

The initial stage of the environmental investigation was to undertake a detailed assessment of the patterns and types of deterioration to enable damage associated with liquid water (e.g. penetrating rainwater) to be differentiated from that associated with water vapour (high relative humidity or condensation).[10]

Deterioration of the paint layer was found to be widespread, with considerable delamination and flaking as well as extensive microbiological growth, mostly evenly distributed over large areas. (figure 3) The nature and distribution of the deterioration indicated that while significant areas of damage were associated with microclimatic factors, including air movement and the building's thermal as well as hygral properties, some areas of damage were more likely to be caused by liquid water ingress.

The graphic condition record mapped patterns of deterioration against areas of physical weakness in the building structure, identifying possible liquid water routes. (Figure 4) Following an electrical resistance and capacitance survey of the decoration's surface, core samples were taken where liquid water ingress was indicated, to establish the moisture profile through the depth of the wall. Gravimetric

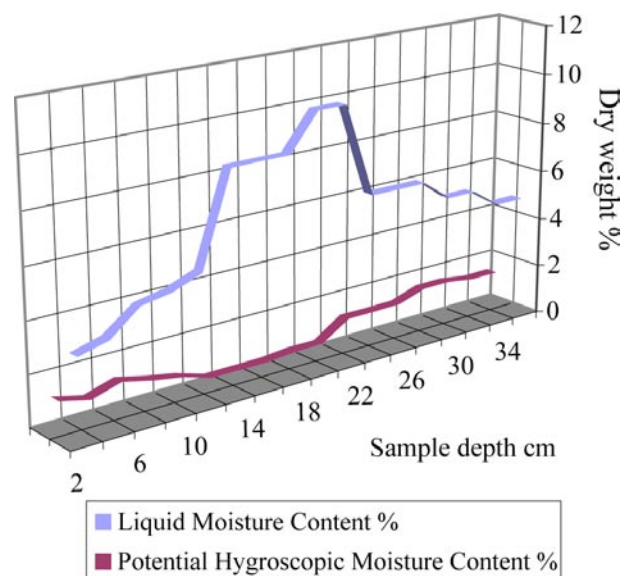

Figure 5. Gravimetric analysis of a core sample on the north wall. The depth is marked from the inside.

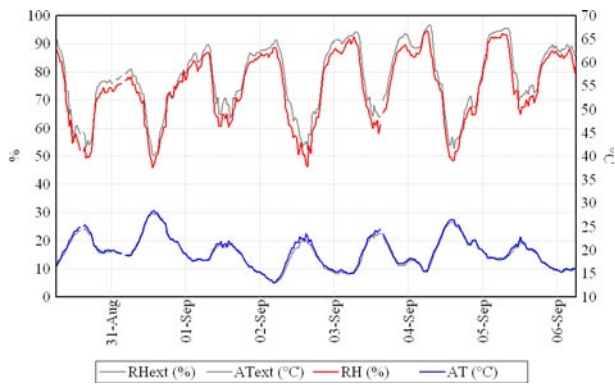

Figure 6. The internal and external relative humidity (RH) and ambient temperature (AT) are almost identical during the open summer of 2005, indicating minimal buffering

analysis [11] of the samples' moisture content enabled calculation of the ratio of liquid water to potential hygroscopic moisture, enabling the routes and sources of moisture to be traced. (Figure 5)

In most areas the wall structure was dry to a depth of over 30cm from the inside surface, suggesting that moisture problems were associated with the microclimate rather than liquid water. On the north wall, high moisture content throughout the wall was associated with a failure of the rainwater drain system on the external wall, and coincided with the most concentrated area of microbiological growth.

Investigating deterioration associated with the microclimate involved monitoring environmental conditions inside the Pavilion, as well as outside.

The data demonstrated that, as expected, conditions within the Pavilion followed the external conditions closely, due to the free air exchange which took place through the two open sides of the building structure. (Figure 6) The fabric provided some minor thermal buffering and the roof protected the internal surfaces from direct rainfall.

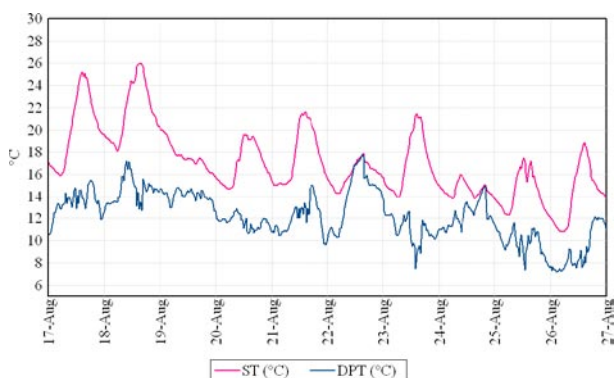

Figure 7. Dew point temperature (DPT) is regularly equal to or in excess of surface temperature (ST) during the autumn and winter of 1999, indicating periods of condensation.

The data showed that high and unstable internal relative humidity (RH) and the thermal lag of the slate frieze and the plaster walls, caused the dew point to rise above the surface temperature on numerous occasions, indicating that superficial condensation was likely to have occurred. Condensation was observed on the painted surfaces many times, including water running down the surfaces of the slate frieze and pooling on the concrete busts, causing slow erosion. (Figure 7) Indeed, sometimes mist accumulating in the valley was seen to fill the Pavilion.

The environmental investigation demonstrated that while some localised areas of deterioration were associated with penetrating rainwater caused by damage to the building envelope, and rainwater disposal system, most of the damage to the decorative surfaces was caused by the instability of the microclimate, and the resulting frequency of condensation. While some damaging conditions were observed throughout the year, by far the worst conditions occurred between October and February.

ENVIRONMENTAL CONTROL

The concept of providing protection only during the worst months of winter weather reflects the approach of the National Trust and other organisations caring for historic houses to the preventive conservation of garden statuary. Vulnerable pieces are covered between November and March, although the gardens may be accessible during this period, following historic precedent.[15] As any visible methods of protecting historic material can adversely affect its appearance, our initial aim was a method of control that had minimal visual impact. Establishing a system of control was an iterative process, testing defined variables separately over a single winter season. Each intervention was carefully assessed to determine its advantages and disadvantages and the results used to develop the approach tested in the following season. Interpretation panels explained the project to visitors during the winter months. Whilst we hoped that to develop a simple control method with minimal visual impact such as heating tapes, our testing demonstrated the need for a more for a complex form of control.

HEATING TAPES

Initial tests in November 1999 used electrical anti-condensation trace heating tapes at the base of the wall and on the lower edge of the frieze. The intention was to establish a curtain of warm air which would slightly heat the wall surface and generate gentle air



Figure 8. External view of the Pavilion with the initial plastic-covered enclosure

currents, reducing condensation by raising surface temperature above the dew point temperature. While the principle has worked indoors [16], the tapes' effect in a semi-external location was overwhelmed by wind.

HEATING TAPES AND UNINSULATED ENCLOSURE

In order to reduce the disruptive effect of the wind, and to test if increasing the hygrothermal buffering improved the conditions, further tests were carried out by enclosing the open walls of the pavilion with uninsulated plastic panels inserted into the two wall openings. Monitoring data showed that enclosure reduced the influence of external water vapour concentration on the internal microclimate and also prevented rain entering. However, Although the internal microclimate was somewhat stabilised, enclosure caused the RH to fluctuate at very high levels (often over 90%). During this period the warm airflow generated by the heating tapes had little effect on condensation, apparently due to the overwhelming influence of the high RH.

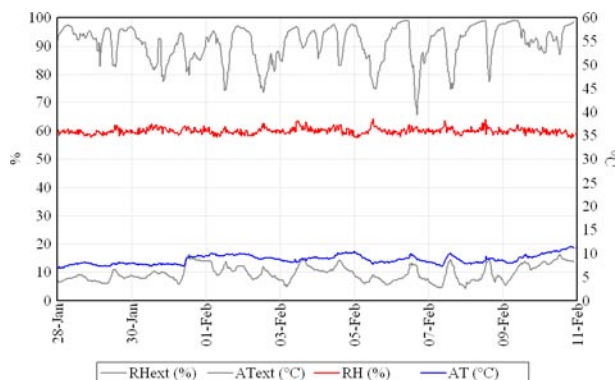

Figure 9. Internal and external relative humidity (RH) and ambient temperature (AT) in the winter of 2005 during enclosure and dehumidification, demonstrating the high level of buffering

During the first half of the following winter, 2000-2001, thermal buffering was tested by adding rock wool insulation to the plastic panels and polystyrene insulation to the windows. (Figure 8) Although the internal microclimate was stabilised, enclosure again caused the RH to rise to over 90%, as the structure contained a large volume of water absorbed during the rest of the year. As a result, the dewpoint remained close to the surface temperature, resulting in numerous events of condensation and significant microbiological growth.

AH CONTROL

As passive thermal control (thermal insulation only) was clearly unable to maintain the RH at an acceptable level, active thermal control (humidistat controlled heating) was considered. However, calculations suggested that the use of heating would be unsuccessful in reducing the RH due to the possibility that increasing temperature was likely to encourage further desorption of humidity from the porous fabric, thus maintaining the RH at its original high level. In addition, increasing temperature in combination with high RH was likely to encourage microbiological growth.

DEHUMIDIFICATION

Tests using mechanical dehumidification were carried out over the second half of the winter of 2000-2001 and then over the following two winters.

Dessicant dehumidifiers, with an absorbent wheel of silica gel are more efficient in their drying capacity at temperatures approaching 0°C, than those that work on the refrigerant principle. Given that the Pavilion is an outdoor structure, a dessicant model was chosen. Initial trials were made with an

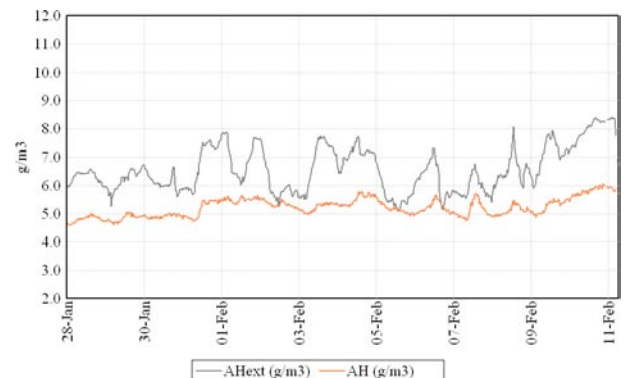

Figure 10. Internal and external absolute humidity (AH) in the winter of 2005 during enclosure and dehumidification

already available small unit which expelled damp air through ducting to outside. A significant reduction in condensation events was monitored, though, through infiltration of external air, the RH reduction levelled off at about 70%. When a condensing desiccant unit was obtained, the performance improved. RH was maintained at approximately 62%, the level set on the humidistat, and below generally accepted levels for mould growth. Mean diurnal fluctuations were generally less than 4% (while externally 35%) and surface condensation was all but eradicated. Combining passive buffering with active reduction of RH achieved conditions beneficial for the conservation of the decoration. (Figures 9 & 10)

COST-BENEFIT ANALYSIS

As tests indicated that a successful means of controlling RH and condensation during winter months was possible, a performance specification was developed for costing an enclosure system to replace the insulated plastic panels, for use between October and April. The enclosure had to be sufficiently robust yet simple in design to enable repeated erection during the winter and removal and storage in the summer. Following the contractor's response, a cost-benefit analysis demonstrated that the costs of enclosure and environmental control were broadly equivalent to the cost of repeated conservation and restoration based on the evidence of the 10 year treatment cycles carried out in recent history. However, the enclosure has the added benefit of prolonging the life of the authentic decoration. The final enclosure system was considerably more efficient than the test system, as well as being aesthetically more acceptable. (Table 1).

Item cost per year	Dehumidified aluminium enclosure	No enclosure
Enclosure (erected by property staff) cost divided by design life of 20 years.	£310	n/a
Dehumidifier cost assuming 10year life cycle.	£130	n/a
Redecoration estimated at £9,000 every 10 years without an enclosure, every 20 years with an enclosure.	£450	£900
Surface cleaning, estimated at every 3 years without an enclosure, and every 6 years with an enclosure	£40	£80
Conservation of slate frieze estimated at 20 years with an enclosure, n/a if redecoration.	£150	n/a
Total	£1080	£1080

Table 1. Cost-Benefit Analysis

DESIGN OF ENCLOSURE

The performance specification for the enclosure included criteria that not only addressed conservation - such as reversibility and minimum intervention, and insulation (u values equivalent to the rock wool tested, for example); but practicality (easiness to clean, maintain, carry, erect and store, robustness to prevailing weather, sun and UV, and a lifespan of minimum 20 years); aesthetics; health and safety (including flammability); security and access; value for money; green principles; and most critically, accommodating the dehumidifier.

In practice, this meant a modular system of interlocking panels with carrying handles, formed of rustproof brush-painted aluminium panels with stainless steel fixings. (Figures 11 & 12) The panels are self-supporting and interlock when in place, as well as locking into position from inside. They are erected by property staff (gardeners and house staff), and stored on a rack with a cover. Access is provided by one set of panels having a lap joint on one edge, enabling hinges and locks to be fitted. Viewing panels with rounded corners and rubber trim, enable visitors to see the interior (with illumination) while the enclosure is in place, and the conservation approach is explained with interpretation panels.

Reversible fixing methods that avoided damaging the Pavilion's historic fabric meant that the panels were made slightly smaller than the arched openings. The panels' edges were fitted with 'rubber' gaskets that could be expanded to fit by self tapping spring-loaded screws and bolts at the edge. Seals were formed of Plastazote® strips around the stone arches and brush strips ('Centaur') fitted at the top and bottom. The screen was constructed of aluminium framework with aluminium infill panels insulated with 22mm black Plastazote®. The foam



Figure 11. Detail of the construction of the enclosure

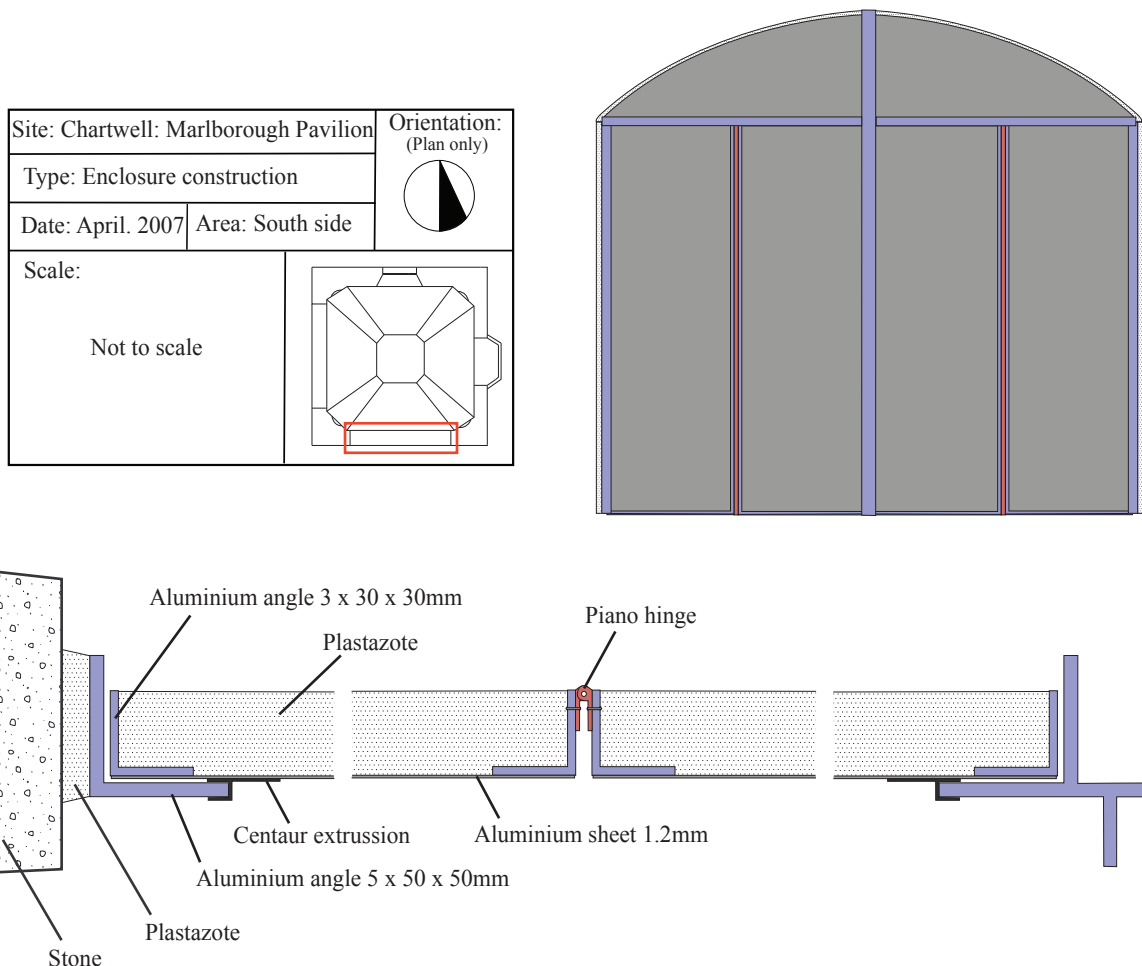

Figure 12. External view of the Pavilion with the final enclosure

was adhered with a UPVA-based glue used to glue insulation to aluminium in the aircraft industry. The design included some points of cold bridging which could produce condensation, but were felt not to be an issue as there was no additional heat to create a significant temperature gradient.

The aluminium and stainless steel elements are projected to last over 20 years, but the finishes will need maintenance. The paint coating will need replacing every 5-10 years, the Plastazote® insulation every 10 years, and the Plastazote® lining to the stonework 5 years. Experience will test the accuracy of these figures and the cost-benefit analysis.

REMEDIAL CONSERVATION

Following completion of the research programme and the manufacture of the final enclosure, a phase of remedial conservation was undertaken by The Wallpaintings Workshop to stabilise the paint layer and remove accumulated microbiological growths and particulate matter.

Wishab sponges and soft brushes removed surface dirt and algae deposits from the walls, concrete medallions and slate and terracotta plaques. The paint layer on the frieze was consolidated using a solution of Paraloid B72 (2.5% in toluene), applied through Eltoline tissue to minimise the physical impact on the fugitive pigment layer. Detached and lifting paint on the domed ceiling, within the lettering on the painted wood beneath the frieze and on the walls, was fixed using Tylose™ MH300 [19] (circa 5% in deionised water and IMS 1:4), prewetting with deionised water and IMS (2:1) to aid penetration of the adhesive. [20]

Reintegration of repairs to the frieze and slate wall plaques, to reduce the visual impact of condensation drips running down the frieze decoration, was undertaken using matt Golden™

Acrylics. A second protective application of Paraloid™ B72 (2.5% in toluene) was then brushed over the frieze surface through Eltoline™ tissue. Two coats of this varnish were also applied to the slate wall plaques.

MANAGEMENT SOLUTIONS

A management system was established with the property staff so that the installation of the enclosure and dehumidifier takes place as part of usual practice, with monitoring of the microclimatic conditions included within the property's standard environmental monitoring programme, using the currently installed Hanwell monitoring system.

LESSONS LEARNT

Lessons cover both technical and management areas: preventive conservation requires combining both.

- A truly passive energy-free solution eluded us. With the addition of a dehumidifier, thermal buffering successfully reduces condensation events and freeze thaw cycles, resulting in significant reduction of microbiological growth and flaking, with a relatively low energy input. The space is now monitored by the same telemetric system installed inside Chartwell. Energy costs remain to be established.
- We did not use air exchange rates as a means of specifying performance as we did not know what was needed, but they could be calculated from the performance of the existing scheme. The National Trust's environmental strategy is based on air exchanges of up to two per hour for a leaky historic house, compared with a display case performance of 0.1 air exchange per day.
- Our failures may be successes in different contexts, for example, thermal heating tapes may help isothermal glazing for stained glass.
- The green and disfiguring microbiological growth has not reappeared since the enclosure has been used, so the intervals between treatment cycles will be extended. We anticipate that by reducing the worst effects of the external microclimate on the painted decoration as well as other decorative surfaces, the rate of deterioration will have been considerably reduced and the period between interventions increased to prolong the life of the authentic painted surfaces.
- Real time testing of only one variable at a time meant one year was needed for each phase, totalling 7 years. The learning curves of this project, and increasing data on the behaviour of historic materials enabling computer modelling, mean trials might be speeded up in future. We hope that aspects of the system developed here will assist the preventive conservation of decorative surfaces in external and semi-external environments elsewhere.

- Project outcomes need to be integrated with daily life as they are not a one off solution. The National Trust is fortunate in having staff on the ground given preventive conservation training to implement the solution and recommendations of the project. Our challenge is to ensure that the conservation management is so embedded in property management structures, that it is not affected by changes in staff. However, the longer term maintenance required by preventive conservation is not funded under current UK funding models, which exclude endowments.

Visitors have benefited by explanations of the conservation process, and a more attractive and authentic place in which to contemplate both the detail of the decorative scheme, and the distant views of Churchill's beloved Kentish landscape.

ACKNOWLEDGEMENTS

The successful conclusion and continuing implementation of this project depended, and depends on: Chartwell's architects, Purcell Miller Tritton; its conservators, Chris Daintith, Sarah Norcross-Robinson, Siobhan Barratt and Gill Nason; its curators, Cathal Moore and Stephen Ponder; and last, and by no means least, past and present property staff who care for both the house and gardens, in particular Carol Kenwright and Neil Walters. We are also very grateful for the help of the contractors involved, Tom Organ of the Wallpaintings Workshop, and Tim Martin of Context Engineering.

AUTHORS

Tobit Curteis
Tobit Curteis Associates
36 Abbey Road
Cambridge CB5 8HQ, UK
tc@tcassociates.co.uk

Linda Bullock
24 Stevenage Road
Fulham
London SW6 6ES, UK
linda@lindabullock.com

Katy Lithgow
The National Trust
Heelis
Kemble Drive
Swindon

NOTES

- 1 For a history of Chartwell, including the Pavilion and its setting, see The National Trust, Chartwell, Kent, London, The National Trust 1998.
- 2 For an account of the 1949 decorative scheme, see Churchill, John Spencer, *A Crowded Canvas: The Memoirs of John Spencer Churchill*, London, Odhams Press Ltd, 1961, pp. 185-6
- 3 Churchill, *op cit*, p 185
- 4 In a letter dated 15/3/1996 in Chartwell's records, the architect Peregrine Bryant reported that Turville said 'that the paint had more or less worn off completely from the slate panels and he was effectively starting from scratch. His recollection also is that the ceiling to the Pavilion and the walls were replastered completely at that time and he was painting onto new surfaces.' This was confirmed in a telephone conversation with Katy Lithgow in 1997 where Turville described that there was virtually no paint left, and how, having cleaned the slates down, he repainted them in casein tempera and waxed them, and repainted the walls, which had all been freshly plastered and finished with Sandtex® on his recommendation.
- 5 The decorative paint specialist James Finlay scraped down Owen Turville's layer and replaced it with limewash with some casein.
- 6 Bryant *op cit* note 4 above.
- 7 This definition was made by the Conservation Strategy Group of the National Trust in September 2003. The principle of working with change forms one of the Trust's Conservation Principles, common to all of its conservation activities, to be published in 2007.
- 8 Chartwell files record that Acrypol® was applied to damaged parts of the roof in 1995, and repairs begun in Summer 1996 were completed in January 1997.
- 9 Unpublished report by Katy Lithgow, Conservation of the Marlborough Pavilion, Chartwell, 26th March 1997.
- 10 Tobit Curteis Associates, Marlborough Pavilion, Chartwell, Liquid Moisture Survey and Environmental Monitoring of the Painted Decoration, unpublished report, February 1999
- 11 Drilled core samples were taken from the walls and separated into segments. These samples were weighed and then dried at 50° C until a constant weight was reached. The difference between wet and dry weight indicates the free water content as a percentage of the overall weight of the dry sample, as this temperature is too low to drive off water of crystallisation. In order to establish how much of the moisture content may be associated with hygroscopicity, e.g. absorbed water vapour, the dry samples were then placed in a humidity chamber at 75% RH for 24 hours, and the resulting increase in weight subtracted from the free water content measurement. The result establishes whether water content is wholly or partly liquid water.
- 12 An Eltek monitoring system was used, initially hard-wired and then using telemetry, with the base station located in the adjacent house. Relative humidity (RH), ambient temperature (T) and surface temperature (ST) were monitored at several internal locations with data logged at 30 minute intervals.[13] Downloading was undertaken remotely via GSM (cellular network) modem, and data was charted and analysed using Microsoft Excel and Eltek's Darca Heritage software.
- 13 Initially seven sites were monitored to give a representative picture of the walls at various heights and orientations, and these were then reduced to the 3 most significant sites, see Figure 4.
- 14 Eltek Squirrel 1021NL telemetric logging system. RH and AT were measured using Vaisala HMG Z-2 combined probes and ST was measured using EU-U-V2 thermistors. The published accuracy levels for the probes are: Vaisala HMG Z-2 RH +/- 3%, AT +/- 0.3°C. EU-U-V2, ST +/- 0.2°C.
- 15 For an assessment of winter protection of external garden statuary, see Berry, J., David, F., Julien-Lees, S., Stanley, B. and Thickett, D. (2005) 'Assessing the performance of protective winter covers for outdoor marble statuary: Pilot investigation', in ICOM-CC 14th Triennial, Rio de Janeiro, eds I. Verger, pp. 879-887. See also http://www.ucl.ac.uk/sustainableheritage/winter_covers.htm for a description of this joint project between English Heritage, The National Trust, and Historic Royal Palaces.

For an account of the National Trust's approach to controlling relative humidity and caring for external objects, see The National Trust, Manual of Housekeeping: The care of collections in historic houses open to the public, London, Butterworth-Heinemann 2006, pp.102-113 and 578-607.

- 16 The use of heating to create a warm air curtain raising surface temperature above dew point, along with other measures of preventing condensation, is described in Massari, G and I, Damp Buildings, Old and New, Rome, ICCROM 1993, 225.
- 17 Munters M90L controlled with a Meaco humidistat set at 55% RH
- 18 Munters MG50 Dri-Box, controlled with a Meaco humidistat set at 62% RH
- 19 Tylose® MH300 is a cellulose-based water soluble adhesive – methylhydroxy ethyl cellulose produced by Hoechst and available from Kremer, Germany
- 20 Tylose® was chosen in preference to other fixatives such as Paraloid® B72 or water-based acrylics (Plextol® B500, Primal® AC33, etc.) because it penetrated behind the flakes well and did not alter the hue or tone of the colour being fixed.

APPENDIX

HEATING HUMIDISTAT CONTROL

Meaco Measurement and Control Solutions
26 The Avenue
Basford
Newcastle under Lyme
Staffordshire
ST5 0LY
Tel: 0845 838 6963
Fax: 0845 838 6965
www.meaco.co.uk

ENVIRONMENTAL MONITORING SYSTEM (RESEARCH PROJECT)

Eltek 1000RX1 Squirrel datalogger, and Vaisala T/RH probes and surface temperature probes with GSM modem kit + antenna

Eltek Limited
35 Barton Road
Haslingfield
Cambridge CB23 1LL
U.K.
Tel: +44 (0)1223 872111
Fax: +44 (0)1223 872521
www.eltekdataloggers.co.uk

DEHUMIDIFIER MODELS M90L & MG50

Munters Ltd
Dehumidification Division
Blackstone Road, Huntingdon
PE29 6EE
Cambridgeshire
Tel: +44 (0)1480-432243
Fax: +44 (0)1480-413147
www.munters.co.uk

ENCLOSURE

Design and manufacture by Tim Martin at
Context Engineering
Tower House
Talgarth
Powys
LD3 0BW
Tel: +44 (0) 01874 712252

PLASTAZOTE

The grade used for the enclosure lining was black LD29 polyethylene foam (70kg/m³ density), with a u value calculated to be greater than that of brick/stone plaster. Available from:

Polyformes Ltd
Cherrycourt Way
Stanbridge Road
Leighton Buzzard
Beds
LU7 8UH
Tel: +44 (0) 1525 852444
Fax: +44 (0) 1525 850484
www.polyformes.co.uk

ENVIRONMENTAL MONITORING SYSTEM (MAIN PROPERTY)

Hanwell Instruments Ltd
12 Mead Business Centre
Mead Lane
Hertford
SG13 7BJ
Tel: +44 (0)1992 550078
Fax: +44 (0)1992 589496
www.hanwell.com



This work is licensed under a Creative Commons Attribution - Noncommercial - No Derivative Works 3.0 Licence.

MOULD GROWTH PREDICTION BY COMPUTATIONAL SIMULATION ON HISTORIC BUILDINGS

M. KRUS, R. KILIAN AND K. SEDLBAUER

ABSTRACT

Historical buildings are often renovated with a high expenditure of time and money without investigating and considering the causes of the damages. In many cases historic buildings can only be maintained by changing their usage. This change of use may influence the interior climate enormously. To assess the effect on the risk of mould growth on building parts or historic monuments, a predictive model has been developed recently, describing the hygrothermal behaviour of the spore. It allows for the first time to employ the changing surface temperatures and RH for the prediction of mould growth. The calculational assessment of mould growth allows the handling of problems which until now could not be solved with simple estimations or with reasonable metrological expense. The success of refurbishment measures can thus be determined in regard to the risk of mould growth. Calculations for the Rijksmuseum Amsterdam show the possibilities of this model.

INTRODUCTION

Historic buildings and museums are the most visible and important foundation of the European cultural heritage and contribute significantly to the attractiveness and identity of Europe for its citizens and visitors. Therefore we must take care that these invaluable testimonies of our past are maintained and protected in a sustainable manner. Although huge progress has been made with air conditioning and heating technologies while saving energy for modern buildings, most of the damages to collections of works of art in historic buildings are still caused by unfavorable climate conditions. An increasing problem caused by the adaptation of traditional buildings to new uses is the proliferation of mould growth. Knowledge of how to prevent microbiological attack is already needed in the planning stage of interventions. The problem of mould growth will also gain further importance due to effects of climate change, since in various parts of Europe it will become warmer and more humid.

The application of biocides is always accompanied by risks to health and also to works of art, especially when used indoors, and moreover can prevent the

formation of mould fungus only over a limited period of time. A prerequisite for preventing mould fungus without the use of biocides is the knowledge of the boundary conditions under which fungus growth takes place. In reference to the boundary conditions for the growth of fungus it turns out that the decisive parameters of influence like relative humidity [3] and temperature [10] as well as the substrate [8] have to be available over a certain period of time simultaneously in order to enable the formation of mould fungi. Therefore, the main focus of this scientific paper is the development of a planning instrument that aims at predicting the formation of mould fungus. This procedure consists of two consecutive predictive models: the Isoleth Model and the transient Biohygrothermal Model.

HEALTH AND CONSERVATION ASPECTS OF MOULD

People are exposed to mould spores in the air they breathe daily; however, sometimes moulds grow excessively in certain areas and can cause illnesses [7]. The most prevalent effect of mould on human health is caused by the allergenic impact of its spores [4]. Some moulds are more hazardous than others. Different people show a different response to mould exposure. In particular, those with allergies, existing respiratory conditions or suppressed immune systems are especially susceptible to illness. In addition, some moulds produce chemicals called mycotoxins, which can cause flu-like symptoms. It should be noted that the causes and effects of mould exposure on people are not very well understood. For this reason the exposure to an environment contaminated by mould should be restricted as far as possible by preventing conditions suitable for mould growth. Cultural heritage assets are affected by mould both in regard to aesthetic and conservation aspects.

GROWTH CONDITIONS FOR MOULD

For the construction sector, German literature often states a relative humidity of 80% at wall surfaces as the decisive criterion for mould growth, independent from temperature. Sometimes it is mentioned that many

types of mould can also thrive at lower humidity (see for example the draft of DIN 4108-X, Mould [2]). Other growth conditions, namely a suitable nutrient substrate and a temperature within the growth range are usually taken for granted on all types of building elements.

The growth conditions for mould may be described in so-called isopleth diagrams [1]. These diagrams describe the germination times or growth rates. Below the lowest line (isopleth) every mould activity ceases. Under these unfavorable temperature and humidity conditions spore germination or growth can be ruled out. The isopleths are determined under steady state conditions, i.e. constant temperature and relative humidity. The three factors required for growth – nutrients, temperature and humidity – must exist simultaneously for a certain period of time. This is the reason why time is one of the most important influence factors. It can be assumed that germinable spores are present in most cases. This means that mould growth will occur when hygrothermal growth conditions are fulfilled.

ISOPLETH SYSTEMS

Significant differences exist among the various fungus species. Therefore, when developing common isopleth systems, all known fungi were included that can be detected inside buildings. Quantitative statements on the growth preconditions of temperature and humidity have been set up for more than 150 species that fulfill both features, as far as they are given in the literature [9]. Within the Isopleth Model the prerequisites for

the growth of mould fungi of temperature and relative humidity are given at first for the optimum culture medium. These isopleth systems are based on measured biological data. The resulting lowest boundary lines of possible fungus activity are called LIM (Lowest Isopleth for Mould).

In order to include the influence of the substrate, that is the building materials or possible soiling, on the formation of mould fungus, isopleth systems (Fig. 1, left side) for 4 categories of substrates are suggested that are derived from experimental examinations:

SUBSTRATE CATEGORY 0:

Optimal culture medium.

SUBSTRATE CATEGORY I:

Biologically recyclable building materials like wall paper, plaster, cardboard, building materials made of biologically degradable raw materials, material for permanent elastic joints.

SUBSTRATE CATEGORY II:

Biologically adverse recyclable building materials such as renderings, mineral building material, certain wood as well as insulation material not covered by I.

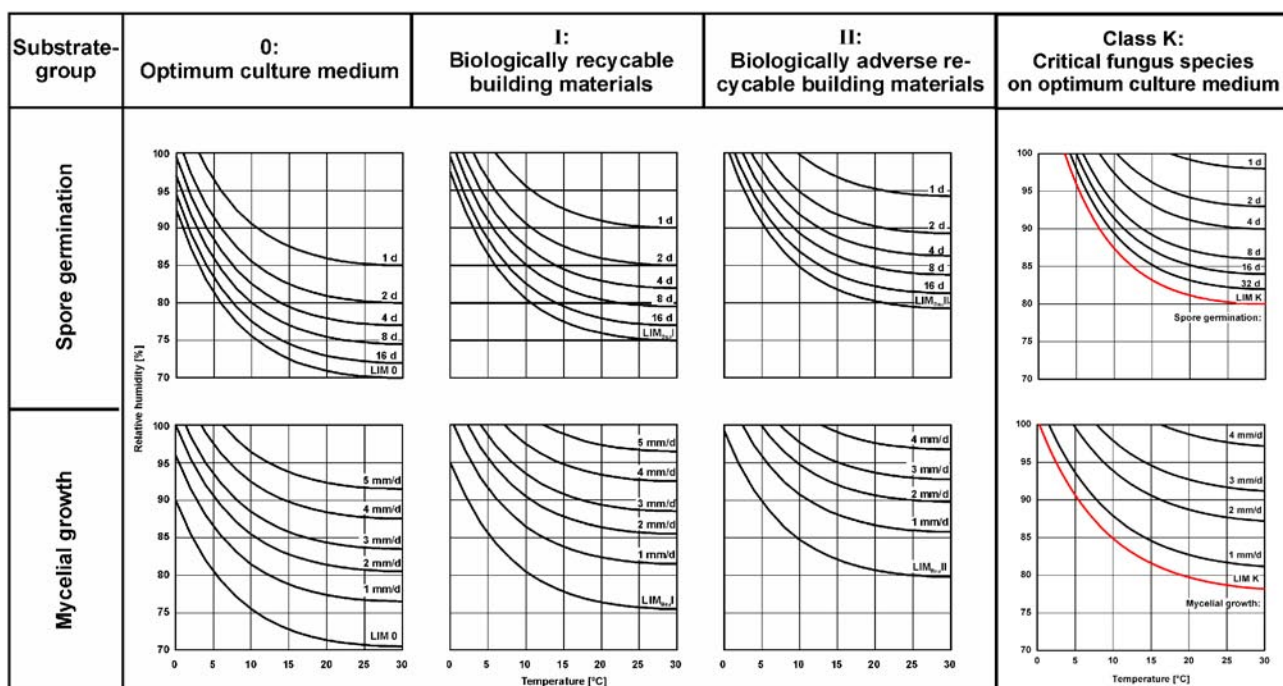

Figure 1. Isopleth systems for 3 categories of substrates, showing the influence of the substrate on the formation of mould fungus [9]. On the right, the isopleth system for the so called critical fungus species (Class K, on optimum culture medium).

Building materials that are neither degradable nor contain nutrients.

For the substrate category III, no isopleth system is given since it can be assumed that formation of mould fungi is not possible without soiling. In case of considerable soiling, substrate category I always has to be assumed. Persistent building materials with high open porosity mostly belong to substrate category II. The basic principle of the new method and of defining the building material categories is to assume a worst case scenario, therefore always on the safe side in preventing the formation of mould fungi. To what extent the isopleth systems can be corrected for individual building material categories towards a higher relative humidity will have to be proved by further measurements. Especially in regard to risk assessment for individual art materials with a high risk of mould growth like canvas, book, leather, etc. further research is needed and planned.

In order to differentiate the mould fungi according to the health dangers they may cause, a so called hazardous class K has been defined as follows [6]: The isopleth system K applies to mould fungi, which are discussed in the literature because of their possible health effect (Fig. 1 right). For the dangerous species *Aspergillus fumigatus*, *Apergillus flavus* and *Stachybotrys chartarum* growth data is available from [9]. The isopleth system for the fungi estimated as critical to health is based on the available data on optimum culture medium. Precise measurements are missing to compile an adequate substrate specific isopleth for the critical fungus species.

BIOHYGROTHERMAL MODEL

For transient boundary conditions of temperature and relative humidity, either spore germination time or the rate of mycelium growth can be determined with the help of these isopleth systems. Yet the assessment of spore germination alone on the basis of the Isopleth Model has the disadvantage that an interim drying out of the fungi spores cannot be taken into account in the case of transient micro-climatic boundary conditions. Therefore in these cases, this process will predict the germination of spores more often than the Biohygrothermal Model. In order to describe the fundamental influences on the germination of spores, this new model was developed.

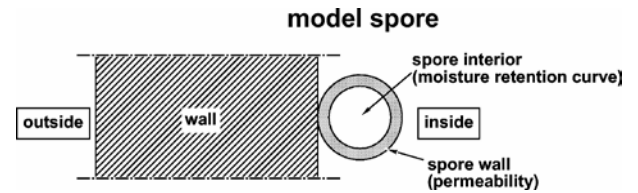

Figure 2. Schematic diagram of the Biohygrothermal Model [9].

The decisive condition for the germination of the spores is the ambient relative humidity, which determines the course of the moisture content within a spore. The objective of the so called “Biohygrothermal Model“ [9] is to predict this moisture balance as it is affected by realistic, unsteady boundary conditions as they are found in buildings, in order to permit predictions of growth probabilities. Of course the moisture content of a spore is also determined by biological processes, but the current knowledge is far from sufficient to allow the realistic modeling of these. It is safe to assume that a spore begins to germinate only above a certain minimum moisture content and that no biological metabolic processes occur before this. Until the end of the germination process, the spore may be considered as an abiotic material whose properties are subject to purely physical principles (see Fig. 2). The Biohygrothermal Model describes the development of the spore only up to this point. Due to the small size of the spore, an isothermal model is sufficient, so that liquid transport processes (such as capillary suction) can be lumped together with diffusion transport. Under these assumptions only the moisture storage function of the spore and the moisture-dependent vapour diffusion resistance of the spore wall are needed as material parameters [5]. According to the assumptions noted earlier, the germination is principally affected by thermal and hygric conditions. Therefore it should be independent of the substrate. But normally the starting point of germination is defined by the first visible growth and not by the start of metabolism. The apparent start of germination depends on the quality of the substrate according to these considerations. This influence of the substrate is taken into account by using the LIMs (Fig. 1) in order to calculate the so called critical water content.

EXAMPLE “RUIKSMUSEUM AMSTERDAM“

The change of use of rooms, storeys or whole buildings will in most cases lead to a change of internal climatic conditions. This is always so if a HVAC system or additional heating is installed. Already during the planning phase of substantial refurbishment measures in the museum it could be foreseen that decisive changes of the interior climate

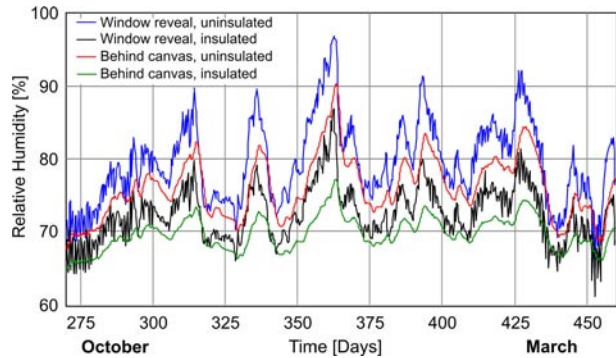
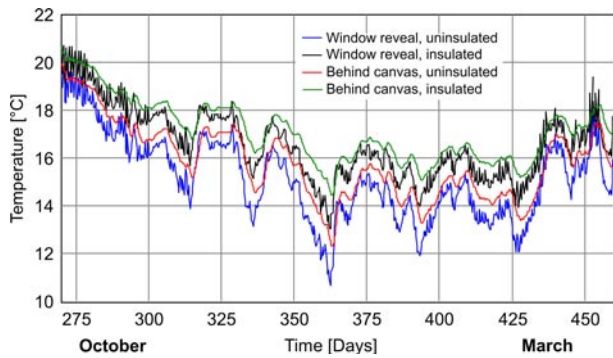

Figure 3. The course of temperature (left) and relative humidity (right) during the winter, at the reveal of a window and behind a canvas painting on the wall [11].

had to be expected, also due to the change of use. Rooms which were used only sporadically or as storage rooms were now to be used for the exhibition of objects of art and as a consequence would have numerous visitors. Additionally, it was planned to fit the climate of the rooms to the requirements of the exhibited objects. This means temperatures between 19 °C and 23 °C at a relative humidity of up to 60 %. Furthermore the single glass windows were to be replaced by modern double glazing to reduce heat losses as well as to improve security against solar irradiation and burglary. The upgraded insulation of the windows results in higher surface temperatures of the windows than of the walls. This means that now the dew point temperature is exceeded first on the walls and not on the windows as before. The probability of condensation as well as of mould growth is increased enormously. Already before the refurbishment the existing building showed moisture problems due to surface condensation. After the realisation of all measures planned, even more adverse relative humidity conditions had to be expected in the room and at the inner surfaces of the exterior walls.

The risk of condensate and mould growth was calculated for critical building details by one and two-dimensional simulations [11]. Measured data were used for the outdoor climate. To counter the predicted RH and temperatures, which are too high and too low respectively, an internal heat insulation made of diffusion-open calcium silicate was projected, because the historic façade had to remain unchanged. This kind of insulation gives higher surface temperatures, resulting in lowered RH at the wall surface. Because of its low diffusion resistance, the drying of the wall to the interior is enabled. Condensate on the wall will be spread due to the high capillarity of the insulation.

Results of the simulation for the reveal of a window and for an outside wall will be shown. The reveal

of the windows is made of sandstone from inside to outside. The simulation shows that because of the high thermal conductivity of the sandstone, especially during winter time, low surface temperatures occur as well as a high relative humidity (10.8°C and 97% RH, Fig. 3). An interior insulation of 40 mm calcium silicate will improve the conditions: the temperature reaches 13.1°C at 87% RH.

It was also planned to hang canvas paintings on the thinner sections of the exterior wall of rooms which had been unused until then. If the wooden frame of a picture is fixed flat against the wall, it can be assumed that because of the feeble air exchange, the air layer behind the picture functions as an additional insulating layer, resulting in lowered wall surface temperatures. The courses of temperature and relative humidity (fig. 3, red and green colour) correspond to the inside surface of the exterior wall behind a picture. The positive influence of the interior insulating layer is obvious. During winter time the surface temperature is increased about 2°C and the RH is lowered about 10 to 15 %. Figure 4 shows the result of the mould growth prediction. Whereas with the interior insulation no mould growth is predicted, without additional insulation, increasing problems have to be expected after the planned change of use.

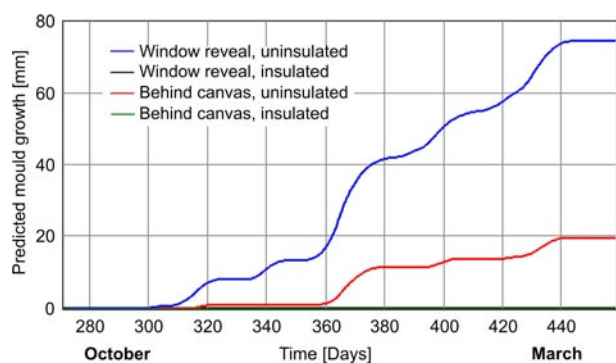

Figure 4. Predicted Mould growth behind a picture fixed on the outside wall and at the reveal of a window without insulation [11]. With insulation no mould growth occurs.

FUTURE WORK

The WUFI Bio software is freely available through the internet and is already being used as a post-processing model for various building simulation systems. The growth model is not yet validated for cultural heritage materials but further research is planned for identifying the growth conditions for micro-organisms on different historic materials used in both movable and immovable cultural heritage. A selection of the most frequently used and the most sensitive materials will be examined at Fraunhofer IBP. The results will be incorporated into the existing analysis software for modern buildings (WUFI Bio) for improved risk assessment for cultural heritage assets.

The course of the relative humidity is strongly influenced by the buffering effects of the building envelope materials and the inside furniture, as well as by the transient outdoor conditions. For the development of suitable ventilation and heating strategies these effects also have to be taken into account. Recently a whole building model for the simulation of the heat and moisture transfer effects which influence the indoor climate has been developed and validated. A combination of this model with the innovative model for the determination of the risk of mould growth makes it possible to assess different temperature and humidity regulation strategies for the preservation of indoor cultural heritage.

AUTHORS

M. Krus, R. Kilian and K. Sedlbauer.
Fraunhofer-Institute for Building Physics, P.O. Box 1152, D-83601 Holzkirchen, Germany,
Martin.Krus@ibp.fraunhofer.de,
www.bauphysik.de

REFERENCES

- 1 Ayerst, G. 1969. The Effect of Moisture and Temperature on Growth and Spore Germination in some Fungi. *J. stored Prod. Res.*, 5, S. 127-141.
- 2 Deutsches Institut für Normung 1999. Wärmeschutz und Energie Einsparung in Gebäuden, Teil x: Vermeidung von Schimmelpilzen (heat protection and energy saving in buildings, part x: prevention of mould growth), Beuth Verlag, draft 10.05.99.
- 3 Grant, C.; Hunter, C. A.; Flannigan, B.; Bravery, A. F.: The moisture requirements of moulds isolated from domestic dwellings. *International Biodeterioration* 25, (1989), S. 259 - 284.
- 4 Horner, W. E.; Helbling, A.; Salvaggio, J. E.; Lehrer, S. B.: Fungal allergens. *Clinical Microbiology Reviews* Vol. 8 (1995), H. 2, S. 161 - 179.
- 5 Krus, M. 1996. Moisture Transport and Storage Coefficients of Porous Mineral Building Materials. *Theoretical Principles and New Test Methods*. IRB-Verlag Stuttgart, S. 1-172, ISBN 3-8167-4535-0.
- 6 Krus, M. & Sedlbauer, K. 2002. Brauchen wir Gefährdungsklassen für Schimmelpilze zur Beurteilung von Baukonstruktionen? (Do we need hazardous classes of mould fungi for the assessment of building parts?), Tagungsbeitrag für das 11. Bauklimatische Symposium der TU Dresden. 26. – 30. Sep. 2002, Dresden, S. 790 – 802.
- 7 Pasanen, A. L.: A review: Fungal exposure assessment in indoor environments. *Indoor Air* 11 (2001), H. 2, S. 87 - 98.
- 8 Ritschkoff, A.-C.; Viitanen, H.; Koskela, K.: The response of building materials to the mould exposure at different humidity and temperature conditions. *Proceedings of Healthy Buildings (2000)*, Vol. 3, S. 317 - 322.
- 9 Sedlbauer, K. 2001. Vorhersage von Schimmelpilzbildung auf und in Bauteilen (Prediction of mould manifestation on and in building parts). Thesis, University of Stuttgart.
- 10 Smith, S. L.; Hill, S. T. 1982. Influence of temperature and water activity on germination and growth of *aspergillus restrictus* and *aspergillus versicolor*. *Trans. Br. Mycol. Soc.*, 79(3), S. 558-560.
- 11 Häupl, P.; Petzold, H.; Finkenstein, C.: Feuchteschutztechnische und energetische Bewertung der Gebäudesanierung mit raumseitiger Wärmedämmung aus Calciumsilikat (Energetic and hygric assessment of an interior insulation with calcium silicate boards), Abschluss-Forschungsbericht, TU Dresden, Februar 2003.



This work is licensed under a Creative Commons Attribution - Noncommercial - No Derivative Works 3.0 Licence.

THE POTENTIAL AND LIMITS FOR PASSIVE AIR CONDITIONING OF MUSEUMS, STORES AND ARCHIVES

TIM PADFIELD, POUL KLENZ LARSEN, LARS AASBJERG JENSEN AND MORTEN RYHL-SVENDSEN

ABSTRACT

The climate in unventilated stores and archives can be entirely passively controlled in temperate regions. Three actual and one simulated archive demonstrate the potential of variants of conservation heating. The heat and humidity buffering of the building and its content must be sufficient to allow the building to cruise through both summer and winter extremes on inertial guidance. This brings the passive climate quite close to the strict limits imposed by standards and guidelines. The increased chemical decay caused by internal pollution accumulating through lack of ventilation cannot be quantified because of a lack of research on the kinetics of gas-solid reactions in stores with multiple levels of enclosures. However, pollutant absorbers are effective in cleaning the air. Extension of passive climate control to exhibition spaces cannot provide a constant climate but is certainly capable of reducing variation in temperature and relative humidity to a useful degree and within the safe limits according to current scientific knowledge.

INTRODUCTION

Passive climate control has mostly been used for archives and museum stores in both historic and modern buildings. The extension of passive climate control to exhibition spaces is rarely found as deliberate design, though it frequently happens



Figure 1. "The environmental adviser said the library will have a more stable relative humidity if the open edges of the books are exposed."

unintentionally. The fundamental requirement for natural climatic stability in a building is a large thermal inertia, usually provided by heavy walls. A second requirement is moisture absorbent surfaces able to stabilise the relative humidity (RH) against the variable water content of the ventilation air. A third requirement is that the building must provide natural temperature uniformity, with no cold corners.

AN ARCHIVE WITHOUT CLIMATE CONTROL: THE MILITARY ARCHIVE OF THE FORTRESS OF SEGOVIA

An example of an almost natural archive climate is the military archive of the fortress (Alcazar) of Segovia in Spain (figure 2). The archive is in the basement



Figure 2. North facade of the Alcazar of Segovia, Spain. The narrow windows just visible over the shrubbery illuminate the military archive. The insert, bottom left, shows the interior of the archive.

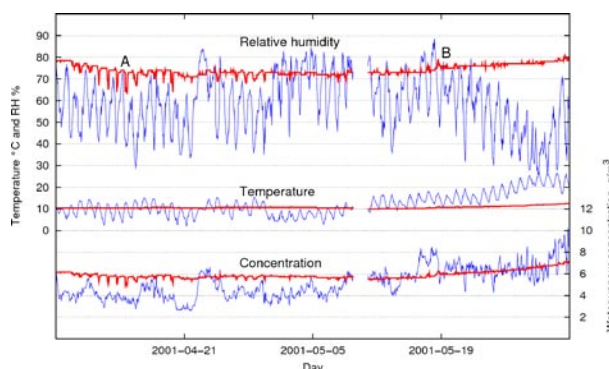

Figure 3. The climate within the Segovia archive, and outside.[1]

of the building enclosed on one side by a stone wall with narrow windows. The other side of the room is formed by the massive limestone bedrock.

The climate in the archive is stable, but rather humid by conservation standards. The archivist fights the humidity by opening windows during working hours. At point A in figure 3 the downward pointing blips in the RH trace show the RH being forced down by the entry of outside air of low water vapour content, with the RH rebounding almost to its previous value when the window is closed in the afternoon. This intermittent ventilation clearly reduces the inside RH by small steps each day. However, the archivist still opened the windows later in the year, when the outside air is generally of higher water vapour content than the inside air. Humans are not good at estimating atmospheric water vapour. The task is best left to automatic machinery which decides by measurement when to pump air.

AN ARCHIVE WHICH IS HEATED IN WINTER: THE SUFFOLK RECORD OFFICE

In temperate climates, heating will reduce the RH without significantly increasing the rate of degradation of the collection. This is known as conservation heating. If the room is also heavily buffered against RH change, summer heating can be avoided. The room will cruise through the summer period with a constant RH, far from water vapour equilibrium with the outside air. A good example of this approach is the Suffolk Record Office in Ipswich, UK (figure 4). The two storey building has narrow recessed windows. The wall is faced with 112 mm brick, then there is a ventilated cavity. Inside this is 110 mm of insulating block, then a second, unventilated cavity, then 300 mm of brick and a coat of 13 mm plaster on the inside. The attic space is ventilated. The building



Figure 4. The Suffolk Record Office, Ipswich UK. The walls are 630mm thick, half of which is brick. It was built in 1990. The architect was Henk Piekema.

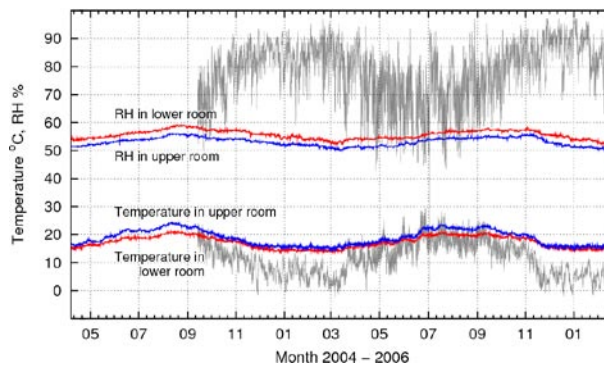

Figure 5. The climate within the Suffolk Record Office. The uneven grey traces are the outside temperature and RH [2]

is heated in winter, but there is no air circulation at all, and no active control of RH. The climate in the archive rooms is shown in figure 5, together with the outside weather. The winter heating reduces the RH sufficiently that there is no need for heating during the summer.

AN ARCHIVE WHICH BORROWS HEAT FROM ITS SURROUNDINGS: THE ARNAMAGNÆAN ARCHIVE

The standard version of Conservation Heating uses a hygrostat to warm to a constant RH. This does not work in a well filled archive, because the RH rises as the temperature rises, causing positive feedback and a runaway temperature. It is better to control the temperature according to the season, raising it well above ambient during the winter and holding it about ambient during the summer.

In the Arnamagnæan archive of Copenhagen University, Denmark [3], shown in figure 6, the temperature is raised pseudo-passively, by leaking heat in from the adjacent corridors and rooms, which are maintained at a temperature for human comfort. The winter temperature outside is allowed to influence the archive temperature through thin insulation on the two outside walls, with thicker insulation on the walls towards the interior. A



Figure 6. The building of Copenhagen University which houses the Arnamagnæan archive behind the windowless section of facade. On the right is a section through the archive. Note the thermal insulation against the interior of the building and the comparatively thin insulation of the outer wall. As a consequence, the archive temperature lies about midway between the outside temperature and the temperature of the core of the building.

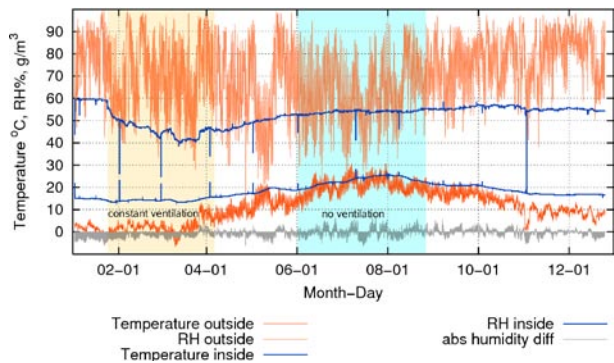

Figure 7. The climate inside and outside the Arnamagnæan archive during tests in 2006 of its resistance to malfunction of the air pumping system. The decrease in inside RH during February and March was caused by deliberately ventilating the room continuously, at 2 air changes per hour, to stress the humidity buffering. During July and August the room was completely unventilated, to test the resistance to the high RH expected in summer. The grey trace at the bottom shows the difference between outside and inside water vapour concentration. Shading above the zero line indicates a higher water vapour concentration outside. The sharp blips on the curves mark short periods when the data logger was withdrawn to the conservator's office for the data to be extracted. These brief retreats reveal the temperature and RH which surrounds six of the eight sides of the archive.

section through the archive is shown in figure 6. The temperature of the room hovers about midway between the inside temperature of the whole building, which is about 22°C, and the varying outdoor temperature.

The RH within the archive is usually controlled by pumping in outside air when, by chance, it has a water vapour content that will drive the room RH to the specified value. In figure 7, however, there are two periods when the pump was deliberately left on or off for long periods. The difference in water vapour concentration between the outside and the inside is shown as the grey shaded areas on the graph. During the winter there is nearly always a lower water vapour concentration outside. This means that the RH cannot be driven upwards by pumping in outside air. The archive has to buffer its own climate isolated from the outside weather. During the spring and autumn there are many periods when the RH can be driven either up or down by ventilation. After the concrete structure has dried, and with growing confidence in the self-buffering of the archive, it should be possible eventually to abandon the ventilation control altogether.

MODELLING THE CLIMATE WITHIN BUILDINGS WITH BOTH THERMAL AND MOISTURE BUFFERING

The Arnamagnæan archive takes heat from the surrounding building, so cannot be regarded as truly passive. It is, however, possible to use solar heating in



Figure 8. The recently constructed building in Ribe, providing storage for the regional museums of southern Denmark.

summer and ground heat in winter to provide entirely natural heating to maintain a constant RH. We don't yet have a measured example but rely on simulation, using a structure similar to the storage building of the regional museums of southern Denmark, in Ribe.

We have used the Danish program Bsim[4]. The simulated building is 20 x 10 x 5 m high, with the long facade facing south and the roof ridge east-west. The walls are made of 240 mm light weight concrete with 250 mm of insulation on the outside. There is an air gap and then a 110 mm brick facing. The flat ceiling is 25 mm of cement fibre board covered by 300 mm of mineral wool insulation. The ventilated roof is steel panels supported by 22 mm fibre board. The floor is 150 mm concrete cast directly on the ground without any insulation. The air exchange rate is once every ten hours.

The course of the indoor climate is shown in figure 9. The temperature drifts from 5°C in winter to 16°C in summer, and the daily fluctuations are around 1°C. The RH is unstable, with 20% changes within the same week, and an annual drift from 40% in winter to 90% in summer. The predicted temperature is close to that measured in the real Ribe building in summer, but in winter the simulated temperature is 2-3°C higher than in the real building. The RH cannot

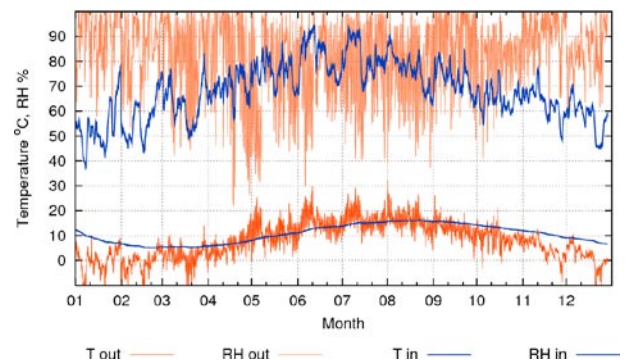

Figure 9. The course of the temperature and RH in the simulated store room.

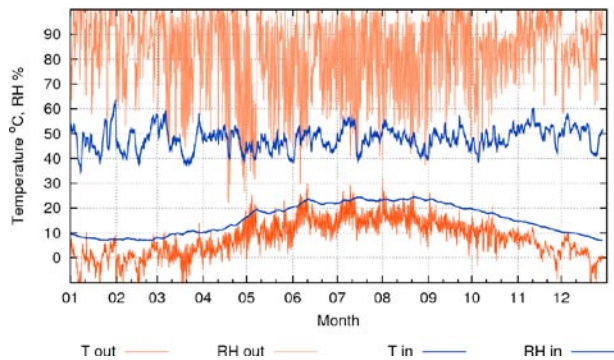

Figure 10. A simulation of the climate in the Ribe store if windows are placed in the roof and the solar heat allowed to warm the ceiling.

be compared, because the real building is always dehumidified.

For the next simulation, figure 10, the building has south facing windows, covering about 10% of the roof. The glass is a low energy type, which transmits most of the sunlight from the outside, but reflects the long wavelength radiation from the inside. To get this solar energy down to the store room the insulation is moved up from the ceiling to the roof, and 200 mm of cellular concrete is substituted for the fibre board ceiling. The inside of the walls is covered with 100 mm of paper. These changes have a dramatic influence on the indoor climate. The annual variation in temperature is from 8°C in winter to 24°C in summer, which brings the RH down to 40-60% all through the year. The buffer effect of the paper lining reduces the daily RH variation from 20% to 10%. Heat from the sun warms the building to the right temperature in summer. During the winter heat is provided from the ground through the uninsulated floor. Some refinements are needed to ensure uniformity of the indoor temperature when the floor is colder than the air in summer, and the ceiling cooler in winter. In a real building, the RH would be further stabilised by the stored artifacts.

MINIMAL CONSERVATION HEATING

A defect of conservation heating is that the higher average temperature accelerates the decay of organic materials. However, in a heavily buffered building it is possible to impose a much smaller annual temperature cycle. The building continues on inertial guidance, holding a constant RH which is often out of equilibrium with the outside water vapour content.

Figure 11 shows the temperature inside varying from about 8°C in winter to 24°C in summer, to give 50% RH throughout the year. This is a large temperature

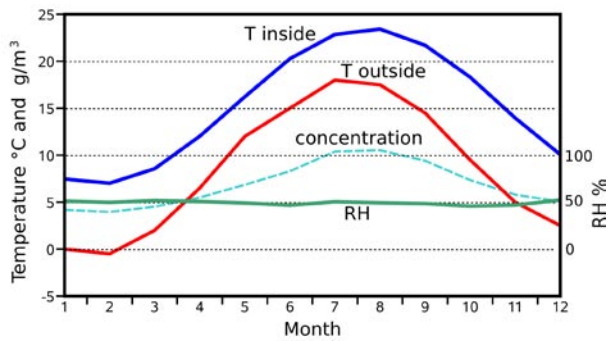

Figure 11. The curves in this graph are derived from the monthly average temperature and RH in Copenhagen over the last 30 years. A room has to be heated to lower the RH. The inside temperature is a sine curve, which gives a RH very close to a constant 50%.

cycle, way beyond what is advised by the current standards for museums and archives.

If we flatten the annual temperature cycle, the RH will automatically develop an annual cycle. This is shown in figure 12. The RH cycles from 38% to 64%, which is only just within the boundaries for avoiding mechanical damage at the dry limit and biological damage at the moist limit. However, the archives show an immense moisture buffer capacity, so it is worth exploring how this can be exploited to make the RH more constant.

There are two ways of ensuring a constant RH through the year. One is to ensure a sufficiently large buffer capacity and a slow air exchange, so the room simply holds the annual average RH without taking any notice of the seasonal change in the outside weather. There is alternatively the semi passive technique as used in the Arnarnagnæan archive. Figure 13 shows that by the random variation of nature, the outdoor water vapour concentration does intermittently intersect the indoor water vapour concentration in a room at 50% RH subjected to the

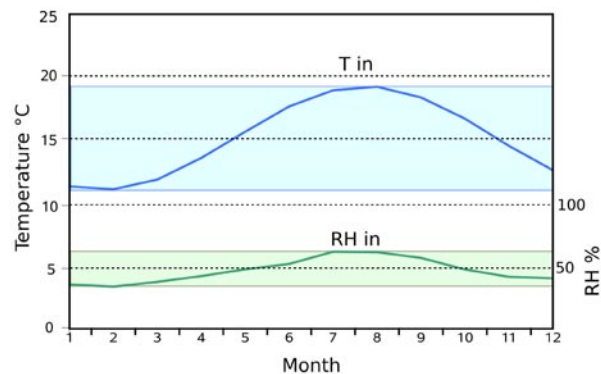

Figure 12. The consequences of flattening the temperature curve from the ideal for forcing 50% RH, as shown in figure 11. The RH cycle is only barely acceptable as a conservation climate but the temperature cycle is now 11°C to 19°C.

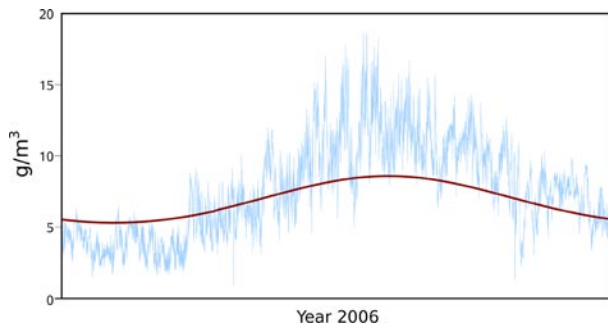

Figure 13. The flatter curve of indoor water vapour content, corresponding to 50% RH at the flattened temperature cycle of figure 12, is here compared with the actual water vapour content of outside air every hour in 2006. Random variation in the weather brings the outside water vapour concentration to pass through the inside value quite often, with not more than a month at a time when the outside concentration is consistently on one side of the inside curve. These intersections allow the inside RH to be changed in either direction by pumping in outside air at a suitable time.

flattened temperature cycle shown in figure 12. At these times, mostly in spring and autumn, outside air can be pumped into the room to correct the drift of the RH away from the set point. Happily, the more unpredictable and variable the weather, the greater the opportunity to correct the error in the indoor RH.

One could argue that air pumps and vapour concentration sensors are hardly passive climate control, but they don't use much energy, and in a room with reasonable thermal and moisture buffering, they are fail safe.

VENTILATION

Ventilation has been advocated for centuries as an inhibitor of fungal growth. Since any ventilation at all will reduce the performance of humidity buffering, and to a lesser extent the stability of the temperature, there is a serious apparent conflict here.

A trawl through the microbiological literature reveals little reliable information about the direct effect of air movement on microbiological growth. The controlling variable for fungal and microbial growth is generally accepted to be the RH, called the water activity by biologists, with some influence from the nutritional qualities of the substrate. The advice to ventilate surely arises indirectly, from the need to ensure temperature uniformity, and consequent RH uniformity, in all corners of the room. It is also true that there are many sources of water vapour indoors and no passive ways of removing water vapour except by diffusion through the outer wall. If one is designing a new building, which is the main focus of this article, temperature uniformity should

be designed in from the start. Corners should be rounded and the external wall should be uniform in structure and porous to water vapour. There should be some lateral heat conductivity in the outer wall, which is easier if it is thicker. All these improvements are easy to incorporate if one is building in earth or massive brick, both of which are currently out of fashion among architects.

Keeping the air exchange low will retard outdoor pollutants from reaching the collection stored inside the archive, which, if the pollutants are reactive, will much reduce the indoor concentration. There will, however, be an increase in concentration of internally generated pollutants, of which the most feared is acetic acid. There is scant information on the chance of such molecules reacting within the object or its immediate container before escaping into the larger space of the room and eventually to the outside. The air circulation within a book is orders of magnitude slower than in a free air space, and the exposed surface for reaction is enormous as a proportion of the air volume. Even though a poorly ventilated archive may offend the human nose, we lack a scientific treatment of how dangerous the stagnant air is to the stored materials.

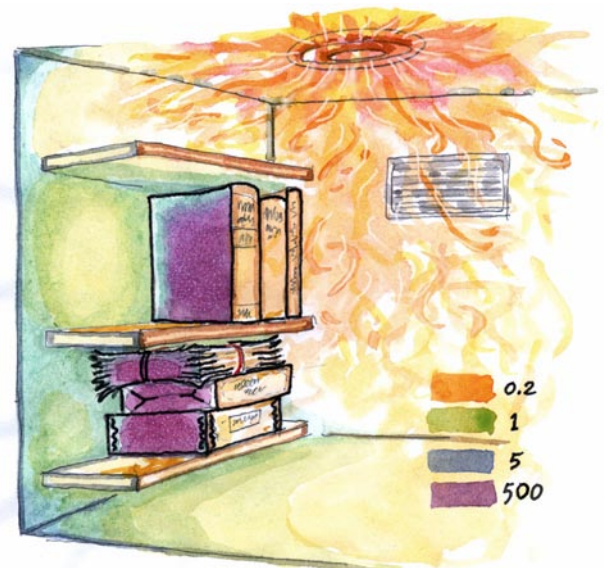

Figure 14. A schematic diagram of ventilation in an air conditioned room. The numbers give the approximate residence time in seconds of an air molecule within a 5 cm cube. The air functions as a heat transfer agent, forcing a uniform temperature in places directly affected by the air stream. Corners can maintain a considerably different temperature and consequently different RH, even if the water vapour concentration is uniform. Unventilated voids such as books and boxes, which are entirely enclosed by ventilated spaces, have the same temperature as the air and do not suffer biological attack more than exposed surfaces. The residence time for an air molecule within a book is assumed to equal that in the same volume of stagnant air.

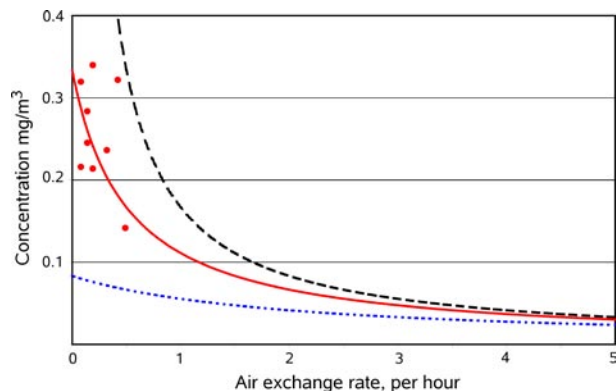

Figure 15. The concentration of an internally generated pollutant at different air exchange rates. The concentration is modelled for steady state conditions in a 120 m³ room for a pollutant emitted into the room air at 20 mg/hour. The highest curve represents no re-sorption on inner surfaces. The middle curve represents a surface removal rate of 0.5 room volumes/hour. The bottom curve represents a surface removal rate of 2 room volumes/hour. The dots mark concentration measurements of acetic plus formic acids in the Arnamagnæan archive.

For mixed collections which consist of both objects that emit pollutants and other objects which are harmed by the same compounds, the simplest approximation is to assume that all pollutant molecules escape from their source into the room air, mix uniformly and are then available to attack susceptible materials. If pollutant removal must be carried out by dilution with fresh air only, the ventilation rate must be a couple of air changes per hour to have a significant effect. This is shown in figure 15 for a room similar to the Arnamagnæan archive.

The top curve in figure 15 shows the situation in an inert room, in which no re-sorption of the pollutants happens. The bottom curve shows the pollution concentration in a room with highly reactive surfaces. Most real rooms will be somewhere between these two extremes, as shown by the spot measurements from the Arnamagnæan archive. A passively controlled archive cannot have an air exchange rate much faster than once every ten hours. Ventilation that significantly reduces the pollution level will destroy the climatic stability. Pollutants can be absorbed by reactive walls but to match the dilution by ventilation would require every surface of a typical archive room to be lined with charcoal cloth. Alternatively, air can be pumped through a carbon filter at two air volumes per hour. This discussion assumes that all pollutant molecules emerge into the room, to be caught by reactive walls. It must be doubted that ventilation has any significant effect on the preservation of objects which themselves are the pollution source, such as stacks of acid paper, or decaying acetate film, because reaction within the immediate container cannot be significantly reduced by cleaning the room air.

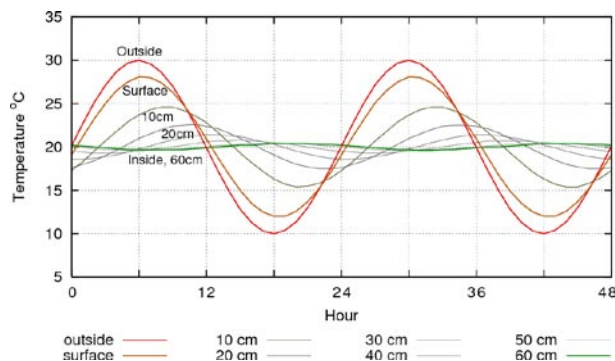

Figure 16. The heat flow through a 60 cm thick solid brick wall subjected to a daily cycle of outdoor temperature. The much diminished wave of heat reaches the inside surface of the wall about 12 hours later.

BUFFERING INHABITED SPACES

For rooms where people will spend some time, as visitors or occupants, ventilation with fresh air is necessary. People need approximately 10 litres per second, which equates to a ventilation rate of 0.5 air changes per hour for a typical work space. For the following discussion a ventilation rate of once per hour is assumed.

Figure 16 shows the variation with time of the temperature through a 60 cm brick wall exposed to a daily cycle on one side. The thermal inertia ensures that the inside surface of the wall is buffered against this daily cycle. Thermal insulation on the outside of the wall will further stabilise the temperature at the inside surface. This wall has a half time to reach equilibrium with a suddenly changed outdoor temperature of about two days. A thicker wall is not necessarily advantageous, as will be shown later. [5]

Quenching the daily temperature cycle sometimes has a moderating effect on the interior RH and sometimes destabilises it. When the incoming air adjusts to the interior temperature, the RH changes, sometimes to a degree that exceeds the variation in the outside RH (figure 17).

It is evident that thermal buffering must be combined with moisture buffering. Figure 18 shows the effect of coating the inside of the brick wall with 20 mm of paper. The moisture buffering effect of this layer depends very much on the air exchange rate and also on the ratio of the surface area of the buffer to the volume of the room. For this simulated building, the ratio of surface to volume is set to one square metre per cubic metre. This ratio is typical of an ordinary house. The indoor relative humidity is now moderated so that it is always less than the variation outside, and often much less.

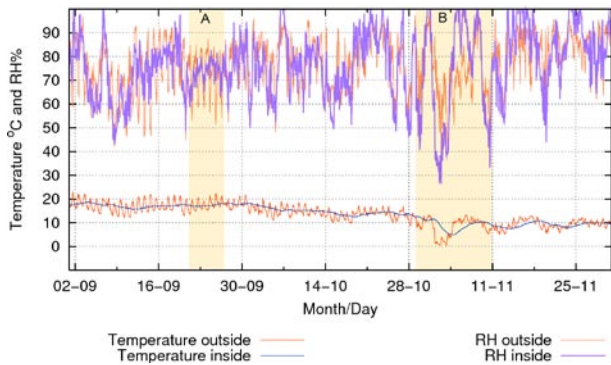

Figure 17. The simulated RH within a building which is well ventilated but has thick walls is sometimes more extreme than the outside RH, and sometimes more calm. During period A the weather is stable and the daily RH cycle is mainly caused by the daily temperature cycle, so the RH variation within the temperature stabilised building is smaller than outside. During period B, however, a sudden change of weather caused a drop in temperature which took several days to pull down the indoor temperature. During this, and the subsequent warming period, the indoor RH variation exceeded that outdoors.

The conservator will remark that the RH variation is still extreme, compared with the variation allowed by museum standards. A reason for this is that RH buffering by materials is feeble and short lived compared with temperature buffering when the air change rate is large. Figure 19 is the moisture analog to figure 16, showing the penetration of moisture, expressed as interstitial RH, through a 20 mm stack of paper. At 10 mm into the stack the influence of the daily RH cycle in the room becomes negligible. It is only the sorbed water in this first 10 mm that is exchangeable to buffer the daily variation in RH. Further progress in exhibition space climate buffering must wait on the development of absorbent walls with a high exposed surface area.

CONCLUSIONS

Passive climate control of archives and stores by increasing their cold season temperature above the temperature outside is so easy and reliable that it should always be applied in temperate climates. The

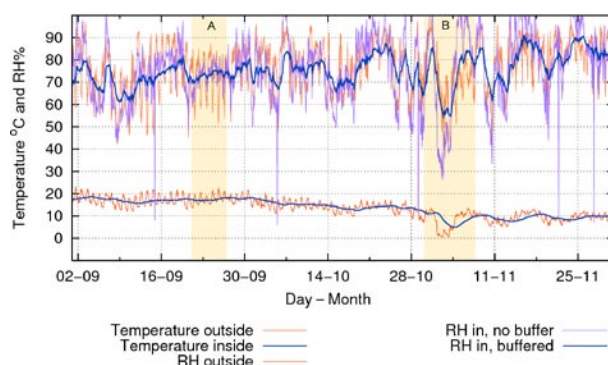

Figure 18. The simulated indoor RH is considerably stabilised by the RH buffer applied to the walls. Now, the inside RH variation never exceeds that outdoors.

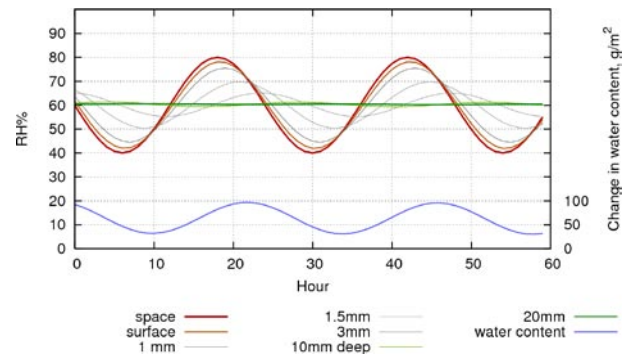

Figure 19. The penetration of water vapour into a 20mm thick stack of paper as the RH varies. The pattern of diminishing influence with depth closely follows the pattern of heat flow shown in figure 16 but the effect vanishes below 10 mm depth. The lowest curve shows the water vapour available for buffering RH in the room.[4]

RH inertia in a well packed store vastly exceeds that of the building itself: the half time for RH equilibrium can easily be extended to half a year.

The threat from internally generated pollutants lingering in an unventilated room can be averted by recirculating the air through a pollutant filter, but the rate of damage from mildly polluted room air has yet to be defined.

Passive climate control of museum exhibition rooms is limited by the large air exchange required by people. Thermal buffering merely requires a massive wall. The principal reason passive control has not been applied is lack of quantitative experiments with RH buffers of large active area to compensate for the slow diffusion of water through absorbent materials.

AUTHORS

Tim Padfield.
May Cottage, Old Road, Harbertonford,
Totnes TQ9 7TA, UK,
tim@padfield.dk

Poul Klens Larsen, Lars Aasbjerg Jensen,
and Morten Ryhl-Svendson.
The National Museum of Denmark
Department of Conservation
IC Modewegsvej, Brede,
DK-2800 Kgs. Lyngby

REFERENCES

- 1 The Segovia climate data were provided by Victoria Smith. The investigation was financed by the EU 5th framework MIMIC project.

- 2 Climate data were supplied by Dominic Wall, The Suffolk Record Office, Ipswich UK.
- 3 The Arnemagnæan archive was designed by HRAS Architects of Virum, Denmark. Climate data were provided by the conservator Mette Jakobsen. We thank the curator Peter Springborg for suggesting and then supporting this initiative in passive climate control.
- 4 http://www.en.sbi.dk/publications/programs_models/bsim (visited 2007/4/10)
- 5 The hygrothermal simulations are based on the computer program described in chapter 3 of Tim Padfield, “The role of absorbent materials in moderating changes of relative humidity”. PhD thesis, 1998. Technical University of Denmark, Series R number 54 1999, ISBN 87-7740-256-1. Also available on the internet: <http://www.padfield.org/tim/cfys/phd/phd-indx.php>.



This work is licensed under a Creative Commons Attribution - Noncommercial - No Derivative Works 3.0 Licence.

SUMMARY

During the period of redevelopment of many museums in Austria and Germany in the last two decades, much emphasis was laid on the improvements of house technique as well as on reducing energy losses in winter. The latter was done sometimes by replacing the traditional double-pane chest windows with single casement windows with insulation glass. But the double-pane chest window is an intelligently developed part of historical museum buildings. If properly repaired, sealed and maintained, and then retrofitted with a physically adequate shading system, such windows are the perfect solution to the opposite climatic stresses of winter and summer.

One of the unexpected consequences of these refurbishments, however, is the fact that sun-exposed (but unsuitably) shaded windows, together with the exhibition lighting, *considerably increase* the indoor temperature in summer. We could quite often observe the same problems under sky-light roofs after the original green coloured glasses were replaced with translucent insulation glass panes.

In this paper I will illustrate that through an improperly adapted chest window, the surface temperature of the inner glass pane can rise above 60°C. On the other hand, it is possible to reduce the surface temperature of the same sun-exposed window down to 31°C at most, only by means of an adequate arrangement of different sheets, coated panes and through natural ventilation of the window chest.

With a physically adequate shading system and a variable lightning concept, the running costs of an exhibition in summer can be reduced to a factor of ≥ 3 .

PHYSICAL MECHANISMS

Although the physical mechanisms and their impacts are very simple, I have observed with growing astonishment over 20 years, that in my sphere of activity, they are ignored or neglected by most architects, curators and museums managers.

The sun emits a wide spectrum of electromagnetic radiation, and a significant part of it generates thermal effects on the indoor climate of a building. The

invisible, mainly thermal effective IR-wavelengths from the sun extends from 780nm to about 2000nm. The visible part of daylight (400 – 780nm) is also radiant energy that can be converted into heat through absorption. The invisible short-wave UV-section, below 325nm, is almost fully filtered out by the glass panes of the window.

Whereas the short-wave UV region mainly causes damage such as fading or degradation of organic materials, the long-wave IR region brings about heating of the entire indoor environment, causing dehydration and damages of shrinkage of all organic materials.

When solar radiation meets a window pane, part of it is reflected, depending on the angle of incidence, a small part gets absorbed by the glass and is released to the environment as thermal radiation. The further behaviour of the remaining radiation will depend on what is behind the pane. The type of window – chest window, one-casement window, compound window – as well as the kind of sun protection devices, will have a direct impact on the thermal behaviour of the window.

Following the oil-shock of the 1970s, new types of window with insulation glass became favoured. On the one hand, the physicists aimed at decreasing the thermal flow through the window to reduce energy losses in winter (insulation glasses). On the other hand, laminated glasses were developed that were either coated with extremely thin layers of metal to reflect most of the IR-region of the spectrum and/or tinted to reduce the transmission of radiation in general (sun protection glasses). The latter are often used by modern architects for sun-exposed buildings with huge glass facades, but are unusual in historical buildings.

The key to understanding the problem of increasing indoor-temperature caused by sun radiation is simple: Most of the light radiation is finally transformed into heat through absorption. Thus three principles must be observed:

1) The positioning of the first plane of absorption is of essential importance – it emits the highest amount of thermal radiation. From a sun protection system mounted in the middle of a window chest,



Figure 1. The Collection of Antique Musical Instruments (SAM) is located on the second floor of the Neue Burg. Its 22 windows face the south-east.



Figure 2. Sun protection measures in the windows of the Collection of Antique Musical Instruments.

about 12% of the absorbed energy emits into the indoor environment. The same equipment, however, mounted inside the room, behind a one-casement window, emits 27% of the absorbed energy.

2) The heat-flow of the absorbed energy must be hindered from reaching the indoor environment.

3) If radiation is absorbed by sun protection devices mounted in front of a one-casement window (outdoor) or between the panes of a chest-window, then part of the absorbed heat can quite easily be ventilated off through convection. If radiation is absorbed by the solid walls or by the indoor equipment of the building – for lack of or ineffective sun protection equipment – then either the indoor temperature will increase significantly, or you will need an air-conditioning system, resulting in significantly higher costs for technical cooling.

CONDITIONS IN THE COLLECTION OF ANTIQUE MUSICAL INSTRUMENTS

The Sammlung alter Musikinstrumente (SAM, Collection of Antique Musical Instruments) of the Kunsthistorisches Museum in Vienna, the oldest and one of the most important collections of its kind, is located since 1965 on the second floor of the Neue Burg, with 22 big chest-windows (each around 3.7m²) facing the south-east (fig.1). Semi-transparent sun protection foils, mounted inside the exhibition rooms, brought about surface temperatures up to 40°C and indoor temperatures rising up to 30°C in summer. Because of extreme climatic problems also in winter, and therefore serious damage on almost all objects made of organic materials, the collection had to be closed and refurbished between 1988 and 1991/93. In consideration of the facts and problems mentioned above, a sophisticated sun protection concept was developed after three years of measuring, observing and comparing. The physically most effective solution – an outer shading system – was forbidden due to the cultural heritage status of the building. All windows were thus equipped *within* the chest space as follows (fig. 2):

1) A roller blind, made out of close-woven linen/cotton was fixed just behind the outer pane (first plane of absorption).

2) A zigzag-folded aluminium-coated sheet of polyester, (57% reflection, and 6% transmission) was mounted in the middle of the window-chest and motor-operated.

3) A silver-coated foil of polyurethane (85% reflection) was mounted next to the inner pane.

4) The window space was ventilated diagonally through a slot in the windowsill and through the opened outer flap of the fanlight (both are shut in winter).

5) The heat-flow from the window into the room, caused by the absorption on the sun protection devices, was minimized by a so-called “3rd pane” – a glass pane mounted in a wooden frame like an additional casement window and screwed tightly to the inner window frame, thus reducing the U-value by 25 to 30% [1].

Through this, it was possible to lower the surface temperature of the inner pane by a value exceeding

10K. Feeling relieved, I anticipated the reopening of the collection.

It was really a shock when, in August 1993, the indoor temperature rose above 31°C – this was even more than before closing the collection to the public! How could that be possible? The answer proved to be very simple.

In 1994, my proposal “Vergleichende Untersuchungen von Heizungs- und Klimasystemen in Museen und Schlössern” (Comparative Studies on Heating and Air-conditioning Systems in Museums and Castles), was accepted by the jury and finally became the EuroCare-Project EU-1383 “Prevent” under the direction of Wolfgang Kippes of Schloss Schönbrunn. The investigation of the windows of the SAM, entitled “The optimal museum’s window”, became a part of the “Prevent”-project [2].

For three years the heat-flows were measured in two sun-exposed chest windows of the Neue Burg, equipped with different sun protection systems. The target of the investigations was on one hand, to look for the most effective sun protection devices, and on the other hand, to find out the cause for the increase of indoor temperature.

The result of the project was as follows:

As the lighting concept was changed from daylight to artificial lighting of the exhibition rooms and show cases, a considerable amount of electric energy had to be installed.

This leads to the conclusion that because of the inefficiency of lamps in comparison with daylight, relatively more electric energy is needed to compensate for the missing daylight [3]. The waste heat resulting from the lighting on top of the remaining heat flow from sun radiation through windows and walls, leads to a considerable increase of indoor temperature in summer (> 28°C). Installing more than 8 to 10 W/m² of electricity requires an effective ventilation system or air-conditioning.

OUTER SHADING AND ITS EVALUATION

The EuroCare project EU-1383 “Prevent” has clearly shown that the present sun-protection equipment between the windows, combined with minimizing the lighting to 8-10 W/m², does not leave any more room for reduction of indoor-temperature. Further improvements could be obtained only by shading systems mounted outside the window, and improved ventilation.

As the Neue Burg is an historical building of cultural heritage, only an “invisible” system was conceivable. The first idea was to decrease the sun radiation input by decreasing the open plane of the window by means of fine-meshed wire nets or expanded metal screens. One of the parameters of such nets is the “open plane” A_o , defining the open space between the wires of the fabric or the bridges of the grill respectively. The idea was that a screen with an open plane of 50% halves the radiation input. So several woven wire nets of stainless steel with different mesh-widths were tested and compared with different expanded metals.

To compare several sun-protection materials simultaneously, four boxes (40 x 40 x 7cm) were made with a bottom of 5mm plywood covered with black paper that served as a radiation absorber. The temperature of the bottom was defined as a measure of the input of sun radiation into the exhibition rooms. The boxes were equipped with the different nets and screens in combination with normal float glass, insulation glass and shade-lite sun-protection glass. The behaviour of a chest window could be simulated with a second frame, put on the glass-covered box.

The development of the temperature of each box was monitored by a Pt-100 sensor. Normally, one of the four boxes, covered with a single float glass pane, was left unprotected as a reference for a window without any shading system (blue curve in fig. 3). Note the significant decrease of radiation input with the expanded metal (red curve) from about 10:45 a.m. onwards because of the geometrical structure of the screen. The net with A_o 22% in these first tests obviously showed the best results (black curve in fig. 3).

Surprisingly however, the measurements had shown that with the decreasing angle of incidence of the

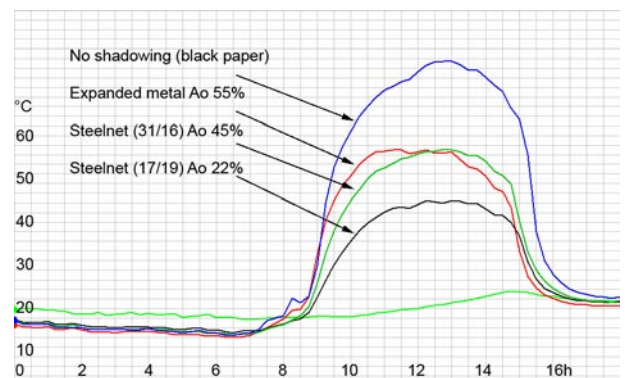

Figure 3. Comparative measurements of metal nets A_o 44% and A_o 22%, and expanded metal A_o 55%. Note the significant decrease of radiation input of the red curve (expanded metal) from about 10:45 onwards because of the geometrical structure of the expanded metal.

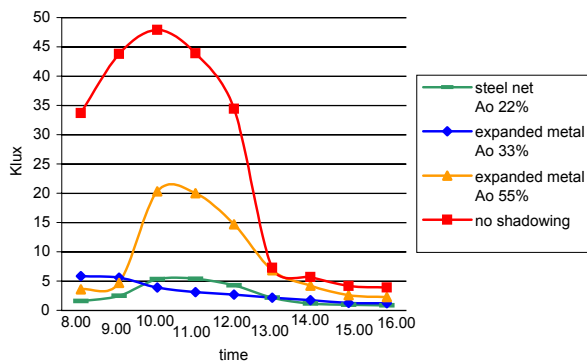

Figure 4. The efficiency of shading expressed as lighting intensity in Klux: Note the significant decrease of light transmission of the expanded metal Ao 33% from about 9:30 onwards.

rising sun, all woven metal nets reflect a considerable part of the radiation into the room, because each single wire serves as a cylindrical reflector. Because of its geometrical structure, the expanded metal turned out to be superior. The stainless steel net with Ao 22% showed worse results than the cheaper and more transparent extension metal with Ao 33%. Fig. 4 shows the different effects of shading of the steel net Ao 22%, expanded metal Ao 33% and expanded metal Ao 55% in comparison with the unshaded window: In this measurement over one day, the light intensity, measured in Klux, served as an equivalent of the radiation input. It can be seen clearly, that the geometrical structure of the expanded metal Ao 33% causes a significant decrease of light transmission from about 9:00 a.m. onwards. Finally a composite frame combining a polycarbonate pane – coated with sun-protection foil – with an expanded metal screen with 33% Ao mounted behind the polycarbonate pane showed the most convincing results (see below).

After selecting the most effective varieties, prototype models were made for two windows in the exhibition rooms to compare simultaneously two variations of the proposed devices to find out the optimal system. In this case, the air temperature within the window chest was measured in both windows as well as the surface temperature on the inner glass pane [4].

DEVELOPMENT OF THE IMPROVEMENT

To demonstrate the efficiency of the single measures, a series of measurements was carried through to show the development of the improvements step by step. The first reference standard was a shading system which was installed in large numbers during the refurbishment of many collections and museums in the 1990s: a single layer of the already mentioned aluminium-coated polyester fabric with 57% reflection and 6% transmission [5].

As meteorological circumstances changed during the experiments, all curves always must be read in their relationship to the reference standard. (In the following graphs the lower value gives the temperature of the inner glass pane, the higher value the temperature inside the window chest.)

- 1.) Fig. 5 shows in the left curve that a combination of a reflecting material (reference standard) with a non-reflecting material (linen/cotton roller blinds), mounted nearer to the outer pane, gives significantly better results. The right curve, however, shows that a third layer, although it is of a high quality (85 % reflection), causes no significant decrease of energy input [6].
- 2.) A significant improvement is the convective ventilation of the window chest (fig. 6). A simple solution is to fix the outer wings in a slightly open but rain-tight position. This reduces the thermal input of the window up to 25%. In our big balcony doors (~ 6m²) a panel at the base of the outer wing was changed into a moveable flap which can be fixed open during the summer period. To support convective circulation a second flap can be opened at the top of the window.
- 3.) The third stage of improvement is to reduce the heat transmission of the inner glass pane. This can be easily achieved by mounting a second window leaf sealed onto either the inside or the outside of the inner window frame, reducing the convectional thermal transmission [7]. A more effective but also more expensive method is to replace the inner float-glass pane with an isolation glass pane. However, this is only possible if the construction of the leaf of the casement window is strong enough. Due to this measure the heat input of the window can be reduced by a further 25-30%.

Fig. 7 shows the partly optimized sun protection system of the SAM since 1991 (triple shading + ventilation of the window-chest + insulation of the inner pane) in comparison with the normal sun protection system. Further improvement is only possible through outside shading.

In the last series of measurements, variations of this partly optimized system became the new reference to investigate the effect of the outer shading systems. Fig. 8 shows a window with triple sun protection in the non-ventilated window-chest in comparison with a window with outer shading by an extension metal (Ao 33%) and triple shading in the ventilated window-chest. In Fig. 9 the outer shading is optimized by a polycarbonate pane covered with a silver-coated PU-foil (transmission 63%), combined with the extension metal Ao 33%; the window chest

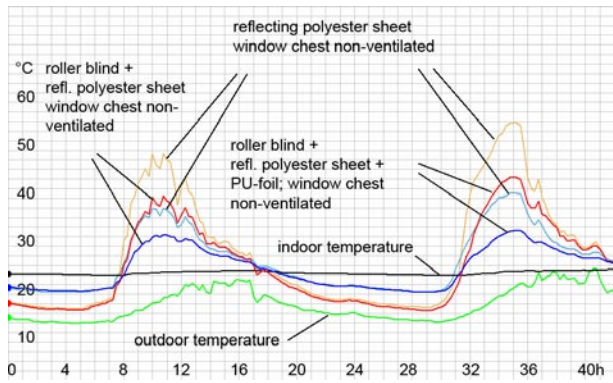

Figure 5. A combination of a non-reflecting and a reflecting shading system causes a significant improvement (left curve). A third layer of a high-reflecting PU-foil shows no significant effect.

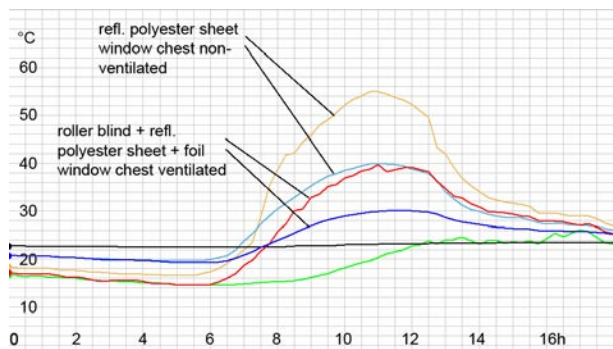

Figure 6. The ventilation of the window chest reduces the thermal input significantly

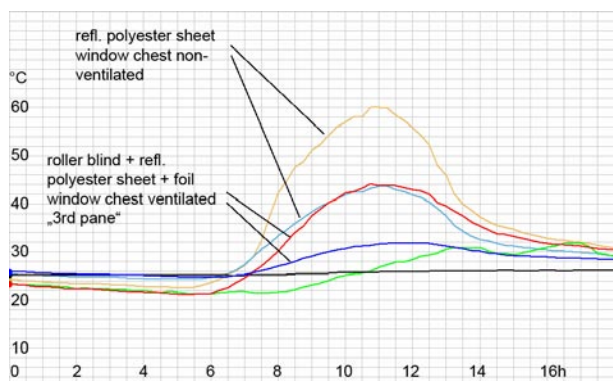

Figure 7. A “3rd pane” or insulation glass at the inner window wing reduces the heat flow from the window chest into the room by about 25%.

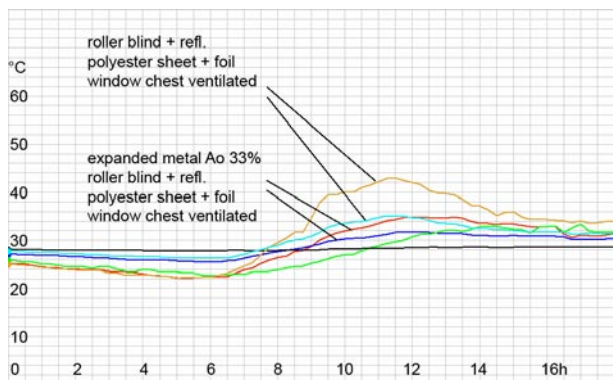

Figure 8. The improved shading system in comparison with outer shading by expanded metal screen Ao 33%.

with triple shading is ventilated. In this arrangement, the surface temperature of the inner pane reaches only 1,5K over indoor temperature.

The full efficiency of this outer shading system can be seen below in fig. 12: The temperature in the window chest of the conventionally treated window (67°C) is 35K higher than in the optimized window. The surface temperature of the inner pane of the optimized window (28°C) is 12K lower than the “normally” shaded window.

OTHER “STANDARDS”

In the Kunsthistorisches Museum several different solutions of more or less successfully working shading systems were installed in the past. To investigate the possibilities of improvement, some of them were simulated. The worst case is the shading of the “Bassano-Saal”. The inner glass panes are covered with black paper – nothing else. This causes surface temperatures reaching more than 60°C (fig. 10). The energy input is compensated by a 4kW air-conditioning device.

In 1990 a controversial discussion took place in the KHM, whether insulation glasses in chest windows should be mounted at the inner or at the outer wing of the window. At least the structural physicist decided to replace the outer float glass pane of the windows of the picture gallery by a double insulation glass pane. In the meantime this decision was revised by experience: the thermal impact caused by absorption at the shading devices is prevented by the insulation panes from flowing to the outside and transmits into the exhibition rooms, which have to be cooled by air-conditioning, causing high running costs. Fig. 11 shows the situation in identically shaded chest windows with insulation panes mounted at the inner and outer wings respectively. A significant improvement is possible, but for this situation only through an outer shading: fig. 12 shows a simulation of the situation in the picture gallery in comparison with the improved sun protection of the musical instruments collection.

Although insulation glasses at the outer wing of a chest window is now accepted as physically wrong, this situation is still “state of the art” within sky-light roofs. The radiation input through the translucent insulation glasses into the roof is absorbed by walls and floors. The heat flows directly into the solid construction of the building, where it is stored by the mass of the brick. An improvement is possible only by two measures:

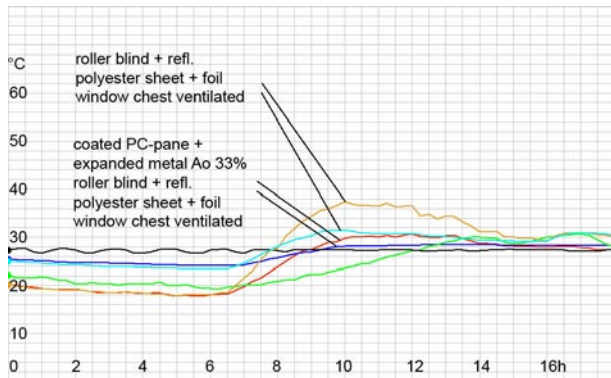

Figure 9. The optimized outer shading: Polycarbonate pane covered with silver-coated PU-foil combined with expanded metal screen Ao33%.

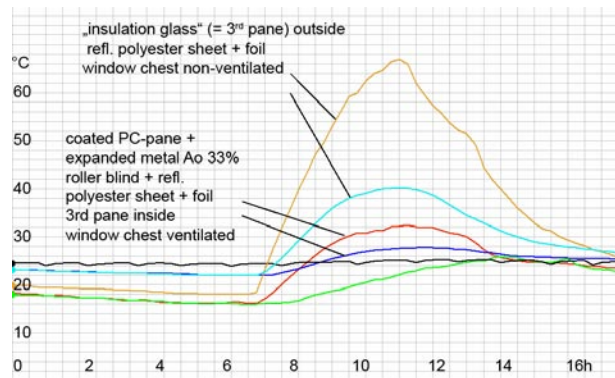

Figure 12. The temperature (67°C) in the window chest of the conventionally shaded window with outer insulation glass is 35K higher than in the optimized window. The surface temperature of the inner pane of the optimized window (28°C) is 12K lower than the “normally” shaded window.

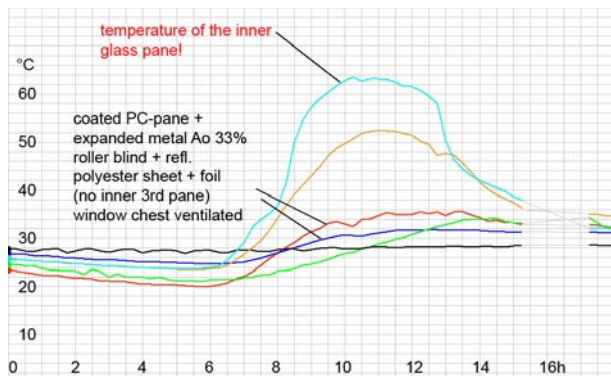

Figure 10. The worst shading system ever found in a museum: A chest window without any shading with the inner glass panes covered with black paper, causing surface temperatures higher than 60°.

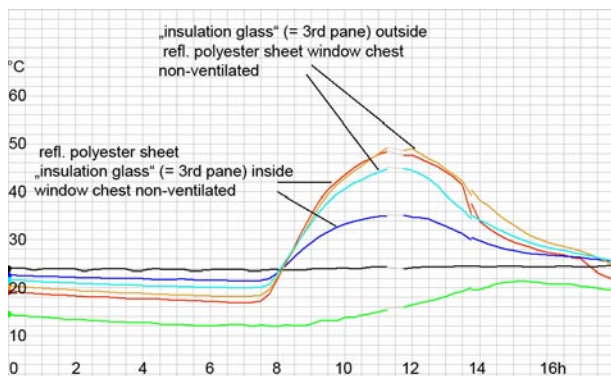

Figure 11. Windows with translucent outer insulation glasses and traditional shading systems cause a higher thermal input than windows with inner insulation glasses.

1. Outer shading or
2. Reduction of about 50-60% of the general transmission of radiation through tinted and metal-coated sun-protection foils applied to the outer glasses (first plane of absorption). An additional movable sun-blind has to be mounted directly under the glass roof to absorb most of the remaining radiation before it can reach the solid brick or concrete construction, from which it hardly can be removed by ventilation, whereas the



Figure 13. During winter, the arches of the loggia of the Wiener Staatsoper are closed by a movable glass construction.



Figure 14. Eight windows of the main facade of the Wiener Burgtheater are covered up with big photographs of actors.

absorption heat between glass pane and sun-blinds can be ventilated off by convection more easily.



Figure 15. Twenty-six windows of the main facade of the Parliament are supplied with outer shading by means of plastic roller jalousies.



Figure 16. Prototype of the optimized outer shading (left) next to the situation since 1991 (middle) and a PC-pane without coating but with an expanded metal blind behind it, mounted in a frame in front of the window (right).

AESTHETIC ASPECTS

To my knowledge, in all traditional Austrian museums any outer sun-protection system - the only physically effective solution – has been forbidden so far with reference to the ‘cultural heritage’ status of the historical building. But until now I never understood why the mere historical appearance of the façade has to be protected more than the thousands of valuable objects contained therein. Meanwhile I know of several examples where the appearance of historical buildings has been changed – not for reasons of conservation but mostly for commercial ones. Needless to say that hardly any public objection was raised. Three prominent examples may be sufficient to mention:

1) During winter the arches of the loggia of the Wiener Staatsoper are closed by a movable glass construction

to protect the visitors of the famous “Opernball” from outside temperatures (fig. 13).

2) Eight windows of the main façade of the Burgtheater are covered up with big photographs of actors (serving as an optimal sun protection for the stair-case and gallery, fig. 14).

3) Twenty-six windows of the main façade of the Parliament are supplied with outer shading by means of plastic roller jalousies to protect our representatives from over-heating (fig. 15).

In comparison with these examples, the proposal for the SAM looks very inconspicuous: Fig. 16 and 17 show the prototype of the optimized outer shading (left) next to the situation since 1991 (middle) and a PC-pane without coating but with an expanded metal blind behind it, mounted in a frame in front of the window (right). The frame has to be fixed in a distance of c. 20mm for cooling the pane by convection. Because of the high extension-factor of PC (0,07mm/°C/m) the pane has to be mounted “swimming” in the frame. It is important for an “invisible” construction that the frame holding the pane has the same colour as the window frame and that the inner contour of the shading frame follows the visible dimensions of the glass pane (without the putty rabbet), so that reflecting and non-reflecting parts, seen from below, show exactly the same dimensions as the other windows of the building without outer shading.

CONCLUSION

It is only a question of time before the waste of energy as well as of financial resources no longer will be accepted by the public. It is simply a nonsense to allow a building to be heated up by sun radiation impact and then to cool it down to “normal” conditions, requiring an enormous amount of energy, technical effort and expense. The proposed outer shading device reduces the input of sun radiation into a building in an inconspicuous and very effective way. With a physically adequate shading system and a variable lightning concept, the running costs of an exhibition in summer can be reduced to a factor of ≥ 3 [8].

AUTHOR

Alfons Huber
Kunsthistorisches Museum,
Sammlung alter Musikinstrumente
Burgring 5
A-1010 Wien
alfons.huber@khm.at



Figure 17. General view of the façade of the Neue Burg, seen from the Burggarten.

REFERENCES

- 1 Expert opinion Nr. 440023
Bundesforschungsanstalt Arsenal, 4.11.1990
- 2 Michael Kotterer, Henning Großes Schmidt, Frederick P. Boody, Wolfgang Kippes (ed.), Klima in Museen und historischen Gebäuden: Die Temperierung. Wissenschaftliche Reihe Schönbrunn, vol. 9, Wien 2004. See also: <http://www.khm.at/files/windows1.pdf> (31.5.2007).
- 3 The luminosity of an incandescent lamp is ca. 15-20 lm/W, of a halogen bulb ca. 22-32 lm/W, of a fluorescent lamp 67-94 lm/W. The theoretical maximum of luminosity, the photometric radiation equivalent, is 683 lm/W. Günther S. Hilbert, Sammlungsgut in Sicherheit 2, Berlin 1987, 14-37.
- 4 The first sensor was mounted on a stick fixed behind the first screen (normally the linen roller blind or the polyester blind) and protected against direct radiation by an aluminium foil. The second sensor was mounted at the indoor-side of the inner pane and covered with a black foamed material serving as an absorber of the remaining radiation.
- 5 Verosol 312, Fa. Adler-Solux

- 6 With a double or triple shading system in a chest window, a high-reflecting material mounted first in the sun beam causes a higher energy input than mounted as the last layer, as the absorption heat of the second and third layer is reflected through the inner glass pane into the room.
- 7 The pane of this second window frame can be made of polycarbonate, which weighs half of the normal float-glass.
- 8 The Antikensammlung of the KHM, equipped since 2005 with new lightning and partial air-conditioning (80 kW/h for 1600 m²), needs about eight times the running costs of the Sammlung alter Musikinstrumente (10 kW/h for 1600m²). Nevertheless, because of its insufficient shading system and energy-intensive performance, in August 2006 the indoor temperature in the “cooled” Antikensammlung (30,5°C) exceeded that of the SAM (29,5°C).

The full version of this paper is to be published in: Technologische Studien des Kusthistorischen Museums, vol. 4, Wien 2007



This work is licensed under a Creative Commons Attribution - Noncommercial - No Derivative Works 3.0 Licence.

EVALUATION OF THE CLIMATE IN A NEW SHARED STORAGE FACILITY USING PASSIVE CLIMATE CONTROL

MICHAEL HØJLUND RASMUSSEN

ABSTRACT

In 2003, The Centre for Preservation of Cultural Heritage in Vejle, Denmark opened and a new shared, storage building was taken into use. The owners of the shared storage are a group of 16 museums and archives. The climate is controlled by use of the concept of passive climatization. The building was made of modern building materials designed to yield a buffering effect against the fluctuations of humidity in the rooms. The humidity inside the storage rooms was expected to range from 45-60 % RH after a 3 year stabilisation period. Wireless radio data loggers were installed to monitor the climate.

Now after 3 years the climate has settled – but there is still a need for the dehumidifiers.

Another aspect of the storage facility is the administrative and practical running of the place. The whole concept of taking charge of the storage facilities has made the preservation efforts of the museums much easier. The users have been instructed in the correct use of the different facilities and they are themselves responsible for correct handling and placement of the objects. The conservation staffs play a supportive role, as consultants, assistants and tutors. The whole process of moving objects in, helping and tutoring the museum employees is an on-going process where good planning and some communication skills are needed.

INTRODUCTION

The Centre for Preservation of Cultural Heritage in Vejle is situated in the northern outskirts of Vejle, western Denmark, and consists of two institutions, Conservation Centre Vejle (established in 1975) and The Shared Storage Facility in Vejle (established in 2003). The two institutions are built together and thus form a physical unit. The Centre is a regional centre for the conservation and preservation of cultural property from seven historical museums in the former county of Vejle. After the abolition of the counties in Denmark in 2006 the institutions are now independent self-governing bodies under the control of two boards representing two different user groups. The seven historical museums constitute a

main part of the user-group in both institutions, but for the Shared Storage Facility the user-group also encompasses three local art museums and a group of local archives.

This article will focus on the running of the shared storage facility and the results achieved up to now. Both technical and administrative aspects will be included, because both aspects are closely linked together in the process of running the institution. Occasionally the conservation centre is mentioned only to give an overall picture of the various roles played by the conservators working here.

The process leading to the decision for and planning of the Shared Storage Facility in Vejle is outlined in an article presented to the ICOM-CC triennial Meeting in The Hague [1].

FACTORS SUPPORTING THE PASSIVE CLIMATIZATION

The Shared Storage Facility is constructed in a way that supports the concept of passive climatization. The idea that the construction and the physical properties of the building materials can contribute to establishing a stable climate on the basis of the outside climate has been discussed by several authors [e.g. 2 and 3]. Christoffersen has given a thorough account of the theoretical background on the use of these principles for the preservation of cultural heritage. In his thesis from 1995 the concept of passive climatization is referred to as the “Zephyr-concept” [2]. According to this the walls, floors and ceilings are constructed and dimensioned so that they will form a solid mass with a high thermal and hygroscopic capacity, good insulation capacity and no unwanted transportation of moisture. This is the same principle known from some older buildings such as churches and castles where the combination of mass and the hygroscopic properties of the materials are responsible for relatively slow fluctuations of temperature and humidity inside the building – which generally is considered a better alternative to no climatization at all.

A stable and passive climate can be established at very low running costs if the building has a high degree of insulation and if the hygroscopic materials in the building can buffer the humidity – as necessary, in combination with a minimum of mechanical climatization such as supportive heating or dehumidification. Moreover, the use of materials and construction principles known from industrial buildings will also save money – a high priority in this case. It is assumed that the building is kept tight and closed and all human traffic and work in the stores is kept to an absolute minimum. This allows the air change rate to be kept low. The smallest interventions, such as the opening of doors and use of light for a longer period will have a destabilising effect on the interior climate of the building.

DESCRIPTION OF THE STORAGE BUILDING

These ideas were adopted when building the storage facility. Finance was a key issue because the only way to persuade the responsible partners to accept the project was to offer something better for the same price as they would usually pay when leasing museum stores. There was also a demand for keeping down the running expenses as much as possible without jeopardizing the climate in the building. Hence the relative humidity (RH) was expected to be somewhere between 40 and 60 % with no more than +/- 5 % fluctuations per day. The temperature was expected to fluctuate in accordance with the outside climate between 7° and 25° C. Provisions for keeping the stores free of frost were made by use of supportive heating in connection with the ventilation plant. In this way it was accepted that the RH and the temperature would fluctuate over a year, but only very slowly. Since the crucial parameter is the RH, it was important that the buffer capacity of the materials (as well as all the other measures taken) would ensure that the fluctuations of the RH would stay within the limits. The air change rate was estimated to be about one per day if the stores were kept air-tight and traffic reduced to a minimum.

The stores were built as 4 halls – in all 5432 m² of floorspace. In each hall, a mezzanine floor was established – covering $\frac{3}{4}$ of the ground space. A large corridor dividing the smaller halls from the 2 larger ones runs through the whole building. The stores and the conservation centre are connected by a building containing various facilities such as registration office, canteen, packing room, cold store and a freeze disinfection compartment (see plan fig. 1).

The storage building was constructed using lightweight concrete elements (1600 kg/m³ according to Danish

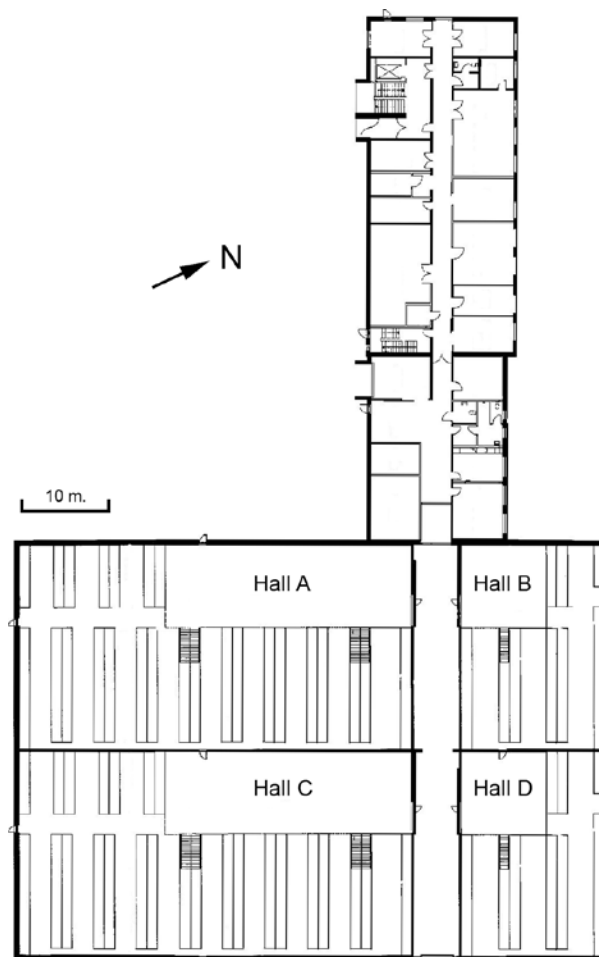

Figure 1. Plan of the Shared storage facilities: The stores (at the bottom) and the Conservation Centre (top). The building connecting the two institutions (middle) contains shared facilities.

Standard 420) with some moisture buffering capacity compared to solid concrete which has no fast acting buffering capacity. The walls were painted white with a cement based paint of high permeability (Skalcem 100 – Z (H₂O)-value <1). In order to store thermal energy, 250 mm of insulation (rock wool) was placed on the outside of the concrete walls. Corrugated steel plating protects the walls. The roof is a light construction consisting of concrete rafters with steel plating in between. On top of that there is a layer of 300 mm insulation material covered by double felted asphalt roofing. The roofs have a slight slope and both interior and exterior drains lead the water from the roof. The floor is made of concrete, insulated against moisture but without thermal insulation so that the ground heat can be exploited during the winter. For the same reason the floor serves as a cooling surface during the summer. The floor is painted with a grey epoxy paint in order to protect it against mechanical wear and the formation of dust. Moreover the surface facilitates easy cleaning and pest monitoring. The light is controlled by sensors so that the light is only on when someone is working in the stores.

In order to take out any surplus of moisture from the building process and to secure a stable RH at critical times during the year it was decided to install a supportive dehumidifying ventilation system. The ventilation system is connected to a dehumidifier and a heater for warming if the air goes below 8°C. The ventilation system is merely a system of tubes recirculating the air in the halls. The dehumidifier was set at 60% RH in the beginning of the period and later (September 2005) reduced to 50% RH. One of the halls (B) has its own dehumidifier and circulation system and the climate here is adjusted for the preservation of archaeological metal objects – the RH is set at 40%.

The Shared Storage Facility was not equipped with a BMS (building management system). There are meters and loggers connected to nearly all power and heat consuming installations, but they are not connected directly to any central monitoring unit. That is why we had to carry out additional monitoring of the actual climate and power consumption in the stores. During the first one and a half years the climate was monitored by daily readings from a hand held digital hygrometer from Testo AG. These data are not shown here, but had the same linearity as is seen in the readings below. From March 2005 the climate has continuously been monitored by a number of radio data loggers from Hanwell Instruments Ltd (type ML2000). One logger is installed in each hall. Though the air change rate is low it must be expected that there will be a difference between RH and temperature near the floor and on the mezzanine. This difference is not suspected to play a major role because the air can circulate freely (due to the industrial gratings in the mezzanine floor) - but it will eventually be investigated.

THE RESULTS – SO FAR

Now, after 3 years of use it is time to evaluate if the storage facilities are working as intended. As can be seen from the graphs below (figs. 2 and 3) the indoor climate is rather stable. The relative humidity in all 4 halls is even and as expected the temperature follows the outdoor climate showing a slow fluctuation over the year. In wintertime the temperature is kept at 7-8°C by very limited heating of the recirculated air (in hall B the temperature is generally a bit higher due to a supplementary heating device). The RH does not fluctuate – the small fluctuations that can be seen are within the limits and they point to the fact that the dehumidifiers are functioning well. It is possible to see the cycles when the dehumidifiers start and stop. And it is very clear at which dates (for instance

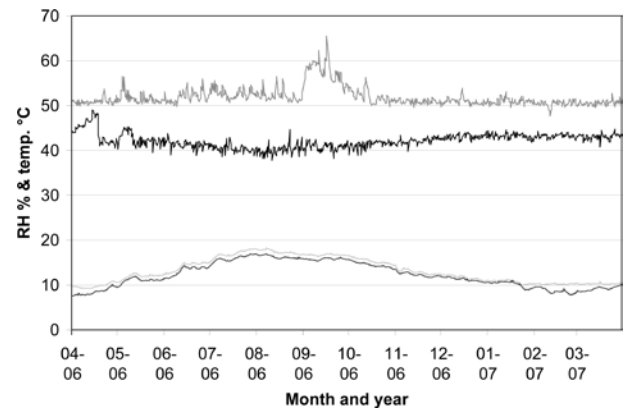

Figure 2. Halls C and B showing the two different climatic zones in the stores (hall C 50% RH (grey trace) and hall B 40% RH (black trace)). Hall C represents the other two halls A and D, since they are being dehumidified by the same plant.

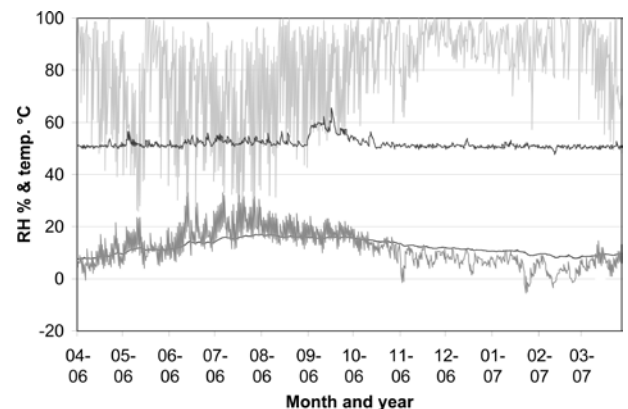

Figure 3. RH and temperature (black trace) in hall C and outdoors (grey trace) during 2006.

September 2006) the dehumidifiers have been shut down – mainly due to power failures. In that case the power failure caused a rise of 10% RH within 2 days. Having detected the failure and restored the power supply the RH was reduced to 50% after nearly 3 weeks.

In Fig. 3 the indoor and outdoor RH and temperatures are compared and the general picture is the same as seen in, for instance, the Regional Archive in Schleswig-Holstein – one of the few places where we have real data from a similar building based on passive climatization [3].

Some times it is possible to see if there have been many visitors or people working for several hours in the stores. This is generally the case when looking at hall A where one of the museums is working regularly with registration of the objects. In general the RH is slightly higher here than in the other stores (see fig. 4). On the other hand, hall A is full and has been so for the last year – the other stores are not yet filled – so one could expect a higher degree of buffering capacity offered by the most hygroscopic

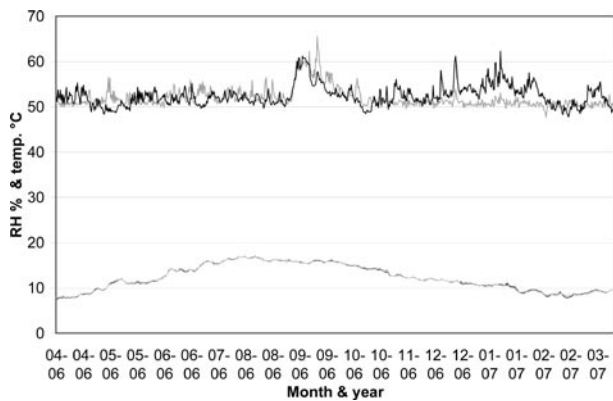

Figure 4. Comparison of halls A (black trace) and C (grey trace). Note the difference between the two RH graphs. The RH in Hall A fluctuates due to more human traffic in that specific store.

materials in the collection. The fact that the objects play a role as a climate buffer has been suggested by Padfield [3] – but it has not yet been investigated in this building, with its huge variety of objects (materials) in the collections.

The graphs, combined with information on the users' pattern of working suggests that people entering the stores for longer periods, or failures of the dehumidifiers, is the main reason for disturbances of the RH.

It is not possible to see from the data available if the building materials (in fact only the walls) offer any buffering of the RH as expected. From a theoretical point of view one could expect that the surrounding materials would play an active role when sudden changes in the RH take place. But since the dehumidifiers are running in frequent cycles it is difficult to determine how much of the moisture is being held back by the building materials and how much is taken up by the dehumidifiers. In future – as the user traffic decreases – we would like to look further into this problem.

Another way to understand the influence of the traffic on the climate of the building would be to measure the actual air change rate at times where there is no traffic – typically during weekends. We hope to be able to carry out such experiments in the future.

In order to get an idea of how much water is removed by dehumidification, it was decided to examine the dehumidifiers' power consumption. A measuring device (Merlin Gerin 10(63)A) was connected to the dehumidifiers, registering the cumulative consumption in kWh. Registration of the power consumption over a period of 9 months shows a relatively steady consumption (average of 477,5 kWh per week), which means that the dehumidifiers are working frequently. From the specifications of the Munters MLT 800 dehumidifiers we know that they are somewhat under

dimensioned, which explains why it takes nearly 3 weeks to reduce the RH after the power failure in August 2006. According to information from climate engineer Lars D Christoffersen, Birch & Krogboe (2001), the dehumidifiers were only meant to take up moisture from the building process and to adjust the RH in the humid periods as a support for the buffering capacity of the building. After 3 years of constant dehumidification the power consumption/running frequency of the dehumidifiers indicates that they may serve as a more permanent solution than originally intended. We believe that the leakage is greater than expected due to much traffic and leaky escape doors in the stores. Because of the relatively low temperature the RH will increase when outside air leaks into the stores – especially during the summer period.

A simple calculation based on the average outside temperature and RH and the inside temperature indicates that the average temperature of the stores is very low and that only dehumidification, a certain amount of additional heat or a sufficient buffer capacity of the building (and the collections) will ensure an average RH of 50%. In other words, the stores are too cold if the climate should be completely passive. The same problem is described in connection with simulation studies on a similar storage facility in Ribe, Denmark by Padfield et al (4).

In our case however, we are quite satisfied with the fact that the objects are being kept at low temperatures because it reduces the risk of chemical and biological deterioration. In spite of the constant dehumidification the running expenses of the stores are still extremely low.

ADMINISTRATIVE ASPECTS OF THE RUNNING OF THE SHARED STORAGE FACILITY

The administrative construction of the Centre for the Preservation of Cultural Heritage in Vejle is a result of the development. The centre is divided into two “sub”-institutions with different funding. The conservation centre is funded by public finances and the shared storage facility is funded by a combination of public finances, funds and mortgage loans.

The Conservation Centre is run by the head of conservation, Lise Ræder Knudsen following the traditional leadership pattern of a public institution. The Shared Storage Facility on the other hand, is run by the users on the basis of self-service. On a daily basis the personnel of the conservation Centre function as caretakers and ensure that the climate

is stable and that the technical installations are functioning. In future we hope to employ a caretaker to take over these responsibilities.

From the very beginning it was agreed that the museums should own the stores on a mutual basis in order to secure a common preservation standard of an acceptable level and to keep down the expenses. The area was shared out among the museums according to their wishes and they pay per square meter. It would have been preferable to split up the whole area into sections of different materials or particular types of objects but this idea was not favoured at the time when the planning took place. The only exception is hall B, which is reserved for keeping archaeological objects and the armour room in hall C – here the security is higher but the climate is the same.

The principle of self-service is only working because it was agreed to follow some strict rules from the beginning. The rules have been outlined in the User's Handbook, which is accepted by the assembly of the users. The conservators have written the handbook and they are constantly evaluating it in order to keep it updated. Since the opening in 2004 many regulations and procedures have been evaluated, changed or added. At the same time the museums representatives – the users and the conservation staff – have been in constant dialogue in order to raise the consciousness and the working standard of the users to an equal level suited for this specific building. It has been difficult really to make people understand the importance of keeping the climate stable by not working in the stores for longer periods and by not keeping the air lock wide open during transport in and out of the stores. These violations of accepted procedures do not seem serious to laymen but they can be read from the loggers and they disturb the climate.

Another thing that the users do not seem to have estimated correctly is the resources and time needed for moving in and recording the objects. Had they done this the whole project may not have come to anything, but right now it means that they have not yet completed the installation of their collections and this again means that the time where the climate could be expected to become stable is constantly postponed.

During the period since the opening of the storage facility the users have generally got used to the procedures and slowly developed a common consciousness of the importance of preservation

principles. This has happened in a constant dialogue with the conservators, and in some cases it has even led to the development of new ways of improved storing procedures. Among the conservators, the cooperation with the users has also led to new and inspiring developments. For instance, a pest management programme has been inaugurated and now both users and the cleaning staff are much more aware of the occurrence of various pests in the stores.

A standard procedure is cleaning and freeze disinfection of the objects being moved into the stores. The users are very observant especially about the freeze disinfection procedure where not all objects can withstand the freezing. In this case the conservators are called in for advice.

A few procedures still need to be tightened up. For instance it is sometimes difficult to keep the aisles clear of objects or equipment – work always seems to be in progress. In some cases this will be allowed after consultation with the board – but generally the stores should be kept in order.

CONCLUSION

In general the climate of the stores is good – the RH is stable and the temperature follows the outside fluctuations on a slow and even curve as expected. The general level of conservation management at the museums and the quality of museum stores has improved considerably.

The RH and temperature graphs combined with the information on the users' pattern of working suggests that people entering the stores for longer periods or failures of the dehumidifiers are the main reasons for disturbances of the RH. Measurements of the actual air change rate will contribute to clarify this problem.

It is expected that the traffic and work in the stores will decrease in time, but we fear that the need for dehumidification will not decrease accordingly.

The main stabilizing factor of the passive climate is – until now – considered to be a combination of high thermal insulation capacity and dehumidification. We doubt the importance of the buffering capacity of the building (and the collection), because of the low temperature and the frequent dehumidification. If possible, it would be interesting to come to a better understanding of the interaction between these factors. Closer investigations of the microclimate

of the Shared Storage Facility will hopefully take place in cooperation with the National Museum, Copenhagen and other partners.

The fact that the User's Manual was agreed on and issued before moving in has been a great achievement because it has allowed the conservators to play the role as caretakers without much authority but still able to act on irregularities. A constant dialogue on an equal basis between conservators and users is another important issue and a condition for a fruitful cooperation and a raised consciousness of preservation in general.

AUTHOR

Michael Højlund Rasmussen
Conservator, M.Sc.
Vejle Conservation Centre
Maribovej 10, DK-7100 Vejle
+45 76 62 11 55
mhr@konsv.dk

REFERENCES:

- 1 Knudsen, L.R. & M.H. Rasmussen, 2005, "Building a new shared storage facility for 16 museums and archives" in Preprints of the 14th Triennial Meeting in The Hague, ICOM-CC, vol II pp.648-654.
A further presentation of the Centre for the Preservation of Cultural Heritage in Vejle can be seen on the institution's website <http://www.konsv.dk> (in English).
- 2 Christoffersen, L.D, 1995, "Zephyr. Passive climate controlled repositories", Department of Building Physics, Lund University.
- 3 Padfield, T. & P.K. Larsen, 2006, "Low energy air conditioning of archives"
<http://www.padfield.org/tim/cfys/>
- 4 Padfield, T., P.K. Larsen, L. Aasbjerg Jensen & M. Ryhl-Svendsen, 2007, "The potential and limits for passive air conditioning of museums, stores and archives."
<http://www.padfield.org/tim/cfys/>



This work is licensed under a Creative Commons Attribution - Noncommercial - No Derivative Works 3.0 Licence.

SUSTAINABLE PASSIVE CLIMATE CONTROL IN DEVELOPING COUNTRIES: A CASE STUDY AT THE NATIONAL MUSEUM OF ART IN MAPUTO, MOZAMBIQUE

LARA BROECKE

ABSTRACT

Passive climate control is often considered preferable to active control in developing countries. However, it is not necessarily easier to implement a passive system which will be sustainable. There are few conservators in the developing world and there is a lack of understanding of their work, making it hard to persuade other staff of its importance. Visiting conservation 'experts' can encounter problems due to the legacy of colonialism, and implementing solutions which appear to be 'cheap and cheerful' compared to those used in the developed world may be seen as demeaning. Time spent working with on-site staff to explain the methods used and get them involved will increase the chances of success in a project; however, winning the support of senior staff is the key, since they will be responsible for delegating tasks and ensuring the continuation of the project. In broader terms, changing approaches to climate control in the developed world, such as moves away from air conditioning towards cheaper and more fuel-efficient methods, will make passive methods more attractive to developing countries and may mean that their implementation will pose fewer problems in the future.

INTRODUCTION

This paper concerns work carried out during an internship at the National Museum of Art in Maputo, Mozambique, in August 2003 and during May – September 2004 [1]. It describes the problems encountered by the museum with air conditioning and dehumidification units and efforts to establish an alternative, simple and cheap means of reducing the relative humidity (RH). While the methods used to reduce RH will be described, the focus of the article is on the difficulties involved in ensuring the sustainability of the passive climate control strategy.

Mozambique is in south-east Africa and has a sub-tropical climate, which means that it is extremely hot and humid during the European winter months and cooler and less humid during the European



Figure 1. The National Museum of Art in Maputo, Mozambique: front view

summer months. The National Museum of Art in Maputo was established in 1989 and is housed in a concrete former office building (fig. 1). The collection consists of modern and contemporary Mozambican paintings and sculpture with a small ethnographic collection and some colonial Portuguese paintings in storage [2]. An American conservator, Claire Gerhard, helped to establish a conservation department at the museum [3] and two Mozambicans, Jonas Tembe and Afonso Malace, were sent for conservation training in Lisbon, subsequently becoming permanent members of staff.

When I arrived at the museum in August 2003 there was no climate control. Records from thermohygrographs showed that RH in the exhibition areas ranged between 53% and 92 %, with monthly averages between 73% and 82%, while the RH reached 100% at times in the basement store. I was aware that some buildings produce good climates for museum objects, and that there is a danger of worsening the environment through attempts to control it [4]. I therefore took measures to establish whether or not the high RH in the museum was causing any problems for the paintings. A condition survey was carried out, and compared to a survey carried out ten years previously. The results indicated that the canvases had taken on large undulations and that paint had flaked, and was still flaking, on a



Figure 2. Rear view of the museum showing air conditioners on the first floor and dehumidifiers in the basement

large scale. It was clear that measures needed to be taken to improve the environment in the museum if the collection was to survive.

During my absence from the museum from September 2003 until May 2004 the museum director asked me to look into possible solutions for the environment. The conclusion I came to was that passive control would be most appropriate. Equipment for air conditioning and dehumidification not only costs money initially, but continues to incur costs due to maintenance requirements and electricity consumption; in addition, frequent power cuts might expose paintings to harmful fluctuations in temperature and RH. Even if a donation were to cover the cost of suitable units and their installation, their continued functioning would not be assured. I therefore decided to see whether the RH might be lowered by judicious opening and shutting of doors; this would cost nothing and would, theoretically, be completely sustainable.

Returning to the museum in May, however, I found that a donation had been spent on four air conditioning units for one of the galleries and two dehumidifiers for the basement store [5] (fig. 2). The air conditioners were domestic quality and were being used for the comfort of visitors during evening lectures. The dehumidifiers worked by condensation and drained straight into a trench running along the back wall of the museum; this meant that there was a danger of the water extracted from the air immediately re-entering the store through the walls and floor. The documentation provided by the company which installed the units noted that they were aiming for an RH of 35 – 50%. This seemed absurdly low, especially considering that the objects in the store had been acclimatised to very high humidity. This had occurred because

the units were installed by a company with no specialist knowledge of museums, in the absence of the museum's conservators. In view of these problems, it seemed as well that no one on the staff knew how to use the dehumidifiers and that one of them was already broken. These new units had cost the museum \$7500 [6].

I had initially assumed that the main problem with conservation in the developing world was money. However, these difficulties with climate control units indicated that the most pressing problems lay elsewhere. The museum directorate had not used the specialist knowledge of its conservators before installing the units. The fact that the air conditioning was used primarily to create a comfortable climate for visitors also demonstrated that the museum's role as a repository was secondary to its roles as a place of education and entertainment. These attitudes are unsurprising given that even in developed countries, where they are now relatively common, conservators often complain of a lack of understanding and respect.

Following my return to the museum, I was given permission by the museum director to devise a means of passive climate control. It was essential that this control should be established and maintained on the smallest possible budget; in this way there would no donors' stipulations, no need to divert funds from other activities, and the climate control would, in theory, be sustainable indefinitely. Another motive for keeping the budget to a minimum was to persuade the museum's conservators that they could carry out effective work using only the resources available to them. Both had expressed a reluctance to engage in work which they felt they would never be able to do properly because of a lack of equipment; as a result they were extremely de-motivated and disinclined to embark on any conservation projects. This circumstance only reinforced the directorate's

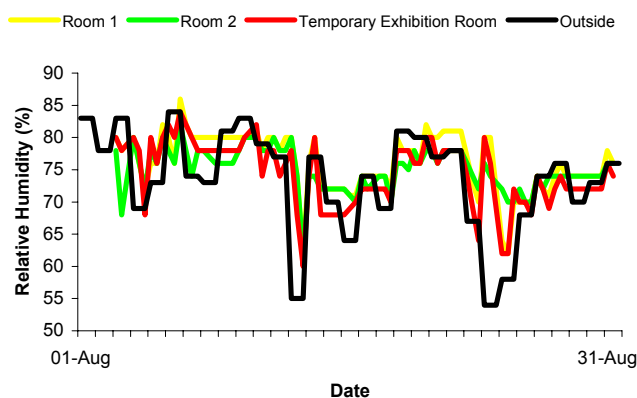

Figure 3. Chart showing the RH outside and in the three exhibition rooms during the month of August 1998.



Figure 4. View of the gallery in which the climate control experiment took place

impression that the conservators had nothing of value to offer the museum [7].

Records showed that there had once been thermohygrographs in the museum. The most recent calibration of these had been noted for April 1998, so I decided to take the subsequent months for comparison with the new figures which I would collect. Comparative data for a larger number of years would have been preferable, but records were often not sufficiently complete and could not be trusted without evidence of calibration. In order to see how the environment inside the museum related to that outside, RH and temperature readings for the relevant period in 1998 were obtained from the local meteorological institute. These were provided in the form of two figures per day – averages for the morning and the afternoon. Although this was not ideal, I thought that if I also made averages for the readings from the museum I would at least have two directly comparable data sets. Two dial hygrometers belonging to the museum were then calibrated at the meteorological institute. The only expenses incurred throughout the project were for these services.

Comparing the RH readings, it was clear that the RH inside the museum responded closely to that outside, but with fluctuations slightly smaller inside the building than outside (except in the basement store) (fig. 3). This suggested to me that large amounts of outside air were entering the building, particularly through the main museum doors, which were kept wide open throughout the day, so that the building had not developed an indoor environment distinct from that outside. Colleagues in Durban, which has a similar situation and climate to Maputo, told me that absolute humidity there was lowest just after midday, and the RH readings for the afternoon outside in Maputo were always considerably lower

than those for the morning. I decided, therefore, to try to encourage air into one of the galleries at dry times of day, by keeping the doors to the museum and the internal gallery doors open in the afternoons, and to exclude it as far as possible at more humid times by shutting the doors. In view of the lowest absolute humidity probably occurring just after midday, it might have been more effective to keep the doors open only for a short period in the early afternoon. However, I wanted to cause the least possible disruption to the museum's established routine, to give the strategy the best chance of sustainability. For this reason, the doors were kept shut from the beginning of the working day, at 7:30am, until the museum opened to visitors, at 2pm, and then the main doors and the doors of the gallery were kept open until the museum closed to the public, at 6pm (fig. 4).

It was essential to get the museum staff interested and involved in the experiment because, if it proved successful, it would be up to them to continue the regime after I left. In order to achieve this I outlined the experiment at a general staff meeting, in Portuguese, although my Portuguese was poor, rather than English, in order to win more sympathy. I was assisted at this meeting by the deputy museum director, who took a vote amongst the staff members on whether I should carry out the experiment. Since all of the staff would be involved in ensuring that the doors were kept in the correct positions as they went about their jobs, it was very helpful that they were given responsibility for the project in this way.

Despite these measures, however, there were problems getting the experiment started. The guards, though stationed close to the doors, were unwilling to close them during the morning if they were left open. In addition, they did not want to take readings at the weekends and between 3:30pm, when my working day finished, and 6pm, when they went home. Since some of this reluctance seemed to stem from a feeling that they were being asked to carry out menial tasks which I would never be willing to perform myself, I took the half-hourly readings from 7:30am until 3:30pm myself and made sure to check the doors frequently and adjust them if they were in the wrong position; I explained to the guards each time why I was doing this [8].

After about a week I found that readings were being taken in my absence, and an intervention by one of the museum's conservators ensured that the guards kept the doors in the right positions during the day. This intervention, though welcome, showed that the

reluctance to participate was due to the request coming from me, rather than a Mozambican colleague, and pointed to a resentment towards outsiders taking control. Similar resentments can be seen in institutions in developed countries, when consultants make fleeting visits and advise people, for a large fee, on how to do their jobs. In Mozambique the problem was compounded by a history of Europeans treating Africa as a playground [9].

This problem extended to the directorate of the museum. Ostensibly they welcomed me and approved my projects; in practice, however, they frequently hampered my work. In one instance the museum director repeatedly organised meetings of all museum staff to clash with a workshop for the staff on handling works of art, the date and time of which I had previously arranged with her. On another occasion I was told by the museum's deputy director that I could not carry out any work unless accompanied by one of the museum's conservators, despite his being well aware that the conservators were often absent from the museum for most of the day. The conservators were not reprimanded for their absence and I was effectively prevented from working [10]. In a similar way, my efforts to lower RH in the museum were approved at a meeting chaired by the deputy director of the museum, but when the guards refused to participate there were no repercussions. My feeling was that the directorate aimed to 'put me in my place' by these means.

The impression that I was experimenting with the museum for my own amusement in a way which would be unacceptable in a museum in my home country was also a problem, and certainly a person with my experience would never have been given the kind of responsibility in a major museum in the UK which I assumed in the museum in Maputo. Developing countries are often expected to make do with solutions which would not be considered in the developed world and in this case, not only was the museum having to make do with me, as opposed to an experienced expert, but it was also having to make do with a cheap solution to climate control which would never be used in a museum in the developed world [11]. In many museums in the developed world air conditioning and humidifiers or dehumidifiers are used; installation of this type of unit, therefore, was desirable as it allowed the museum to assume equal status with other national museums of the world. Opening and shutting doors, even if it produced as good or better results, was demeaning to the museum's status.

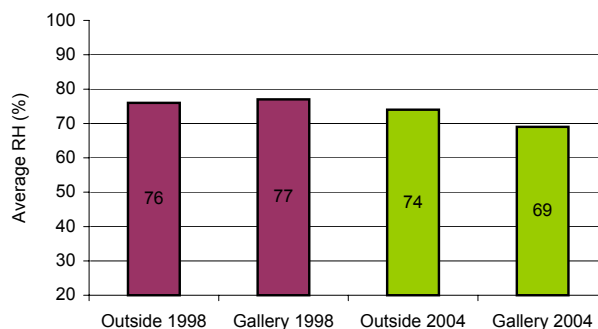

Figure 5. Chart showing average RH for the month of July

After the guards had been persuaded to participate, the recording of results from the hygrometers continued over four months. There were occasional missed readings, but I obtained a fairly complete data set for the hours between 7:30am and 6pm [12]. Data points for every half hour over the same time period in 1998 were taken to give an exact parallel with the new data. For the outside environment I had only morning and afternoon averages from the meteorological institute. However, since this applied both to the data for 1998 and the data for 2004, direct comparisons could be made, and it was possible to see whether the RH in the gallery in relation to that outside was affected by the opening and shutting of the doors.

The results showed that opening and shutting the doors caused the RH in the gallery to drop in relation to the outside RH by an average of 6% when compared with the figures for the same months in 1998 (fig. 5). Records showed that this drop, though small, would ensure that the RH in the galleries would be below 70% for at least half the year, ensuring that new paintings acquired by the museum would be less prone to sagging, cracking and flaking.

Running the same experiment in the basement store for a month, a similar drop was achieved; however, due to very high RH levels this would not be enough to have any beneficial effect on the paintings. Here I could only suggest applying a moisture barrier to the walls and floor and the installation of ceiling fans [13]. These measures would obviously incur initial costs, but would be relatively cheap and would require little subsequent maintenance.

The results of the experiment were presented to the museum's directorate, with the suggestion that the passive climate control regime be permanently incorporated into the museum's routine. It appeared that I had found a cheap and effective solution; sustainability, however, would depend

on the museum staff continuing the work after my departure.

Demonstrating the success of the experiment and thereby showing the importance of climate control to the staff was very difficult, since climate control does not produce instantly visible results. Graphs and tables were shown to the directorate, but staff lower down the hierarchy, who would be enacting the regime, had often received almost no education as a result of wars and poverty and so were unable to interpret the diagrams. In view of this, it was essential for the sustainability of the system that the directorate assigned duties to staff to keep it running. However, my position as an outsider, the directorate's opinion of the museum's conservation staff and the active systems in place in major museums in the developed world made it difficult to persuade them to act. As I left the museum in September 2004 I felt that the system would not be sustainable.

In fact, three years later, the doors of the museum are now kept more or less closed during the mornings. Although the system is not strictly observed, in view of the many difficulties encountered in setting it up and the fact that the doors had been left wide open throughout the day for many years previously, I count this a success. In many ways I should not have been surprised. Although the museum staff were suspicious of me as an outsider and may have wanted to demonstrate their independence from colonial powers by asserting themselves over me, they were nevertheless trained professionals who had the best interests of the museum at heart. In retrospect, their willingness to consider and implement my suggestions seems to show both dedication and maturity.

Discussions with conservators who have extensive experience of preventive conservation work in developing countries have revealed that the difficulties which I encountered are not confined to Mozambique [14]. I therefore offer a summary of the main considerations, in my experience, for creating sustainability in climate control projects in developing countries.

- (i) Money
Initial costs are not so much the problem as continuing maintenance costs.
- (ii) Simplicity
It is essential that non-specialists can understand and implement the system, and that it harmonises with already established routines.

- (iii) Staff support
Establishing good relations with permanent staff and involving them in the project from the outset will help to keep a project running.
- (iv) Awareness of conservation
It is particularly difficult to promote preventive conservation because it has no immediately visible outcome. However, it is important that at least the people at the top of the hierarchy understand its importance, as they can incorporate conservation strategies into the job descriptions of other staff.
- (v) Setting an example
You cannot expect staff to go out of their way to keep a project running if you yourself are not seen to be willing to carry out the day-to-day tasks involved. Similarly, institutions in the developing world will always feel that they are having to make do with second-best solutions if institutions in the developed world prefer expensive solutions to innovative ones where climate control is concerned.
- (vi) Time
It takes a long time to foster trust, understanding and support in people who have very little previous experience of conservation. I felt that six months was a shamefully short time to spend implementing a project of this kind. However, I have since discovered that most projects which involve an outside expert visiting a developing country are considerably shorter. Establishing a routine over time will give a much better chance of sustainability than issuing instructions and then leaving.

Many of the problems discussed above are being addressed. The PREMA project in Africa has raised awareness of conservation amongst museum professionals on that continent [15], and permanent institutions which will continue this work are beginning to appear [16]. The internet can also be used to provide information, instruction and support to conservators working in developing countries. In the developed world, conservators are re-thinking attitudes to climate control, and in many cases passive means are being chosen over active, partly due to financial considerations or the restraints imposed by the structure of historic buildings, but also in response to concerns about the environment [17]. If this trend continues, institutions in the developing world will be able to feel that, far from putting up with second best solutions, they have piloted improved solutions to sustainable climate control in the developed world.

ACKNOWLEDGEMENTS

I would like to thank all the staff at the National Museum of Art in Maputo, Mozambique, and particularly Julieta Massimbe and Jonas Tembe, for giving me the opportunity to work at their museum. I would also like to acknowledge the financial support of the Leverhulme Trust during my internship in Mozambique and the help of John Dean, Gael de Guichen, Bob Hayes, Joan Brink and Marie-Louise Sauerberg in the preparation of this article.

AUTHOR

Lara Broecke,
94 Hailsham Avenue,
London, SW2 3AH,
UK
l_a_wilson@hotmail.com

REFERENCES AND NOTES

- 1 I describe my experiences during this internship more broadly, alongside an account by Jonas Tembe of his experiences as a conservator in Mozambique in: Tembe J and Wilson L. 2005. 'Conserving Paintings in Mozambique: Impressions from Outside and In'. In *The Picture Restorer* no. 27, Spring 2005. BAPCR, pp 5-14.
- 2 The founding of the museum and the political issues involved in deciding which paintings should be included in the collection and displayed are described in Cossa G. 2001. *O Desenvolvimento do Museu Nacional de Arte e a Problemática da Preservação do Nosso Legado Cultural*. In *V Encontro de Museus de Países e Comunidades de Língua Portuguesa Maputo 2000*. International Council for Museums, Lisbon, pp 59-65.
- 3 Claire Gerhard's experiences in Mozambique are published as: Gerhard C. 1999. *Let's Work on This: An American Conservator in Mozambique*. In R Rushfield and M Ballard, eds. *The Materials, Technology and Art of Conservation*. Studies in Honor of Lawrence J. Majewski on the Occasion of his 80th Birthday. New York University: Institute of Fine Arts, Conservation Center, pp 300-10.
- 4 Pearson, Daniel and colleagues have published widely on the dangers of HVAC. King, Daniel and Pearson found that in the Djomi Museum in the Australian tropics, when domestic quality air conditioning was operating, the humidity was high enough for mould growth,

whereas with no control the environment in the building was considerably better. King S, Daniel V and Pearson C. 2000. *Airconditioning Small Tropical Museums: A Technical Note*. In *AICCM Bulletin* December 2000, pp 33-36. Similar problems with air conditioning are reported in Daniel V, Pearson C, Cole I, Ganther W & King S. 2000. *Behaviour of Museum Buildings in Tropical Climates*. In *Tradition and Innovation: Advances in Conservation*. Contributions to the Melbourne Congress. 10-14 October 2000. IIC, pp. 45-50, and more recently in Daniel V, King, S, Pearson C & Cole I. 2005. *Stories From Historic Buildings*. In *ICOM Committee for Conservation 13th Triennial Meeting Preprints*, vol. 1, pp. 625-629.

- 5 The air conditioning units were from Oriima and the dehumidifiers from Westpoint.
- 6 Similar concerns about air conditioning in museums in the developed world are discussed in Oreszczyn T, Cassar M and Fernandez K. 1994. *Comparative Study of Air-Conditioned and Non Air-Conditioned Museums*. In: *Preventive Conservation Practice Theory and Research*. IIC, pp. 144-148.
- 7 A discussion of the problems encountered by people from developing countries trained as conservators abroad and returning to their home countries to find themselves unable to work is found in Pearson C. 1996. *Conservation Training for Developing Countries: The Hopes and Realities*. In *ICOM Committee for Conservation 11th Triennial Meeting Preprints*, vol. 1, pp 122-127.
- 8 Maekawa and Toledo describe a system working on similar principles but using humidistatically controlled ventilators and heaters. This avoids problems with creating extra work for staff, improving sustainability in one way, but requires a continuous supply of electricity, so reducing sustainability in another way. Maekawa S & Toledo F. 2002. *Controlled Ventilation and Heating to Preserve Collections in Historic Buildings in Hot and Humid Regions*. In *ICOM Committee for Conservation 12th Triennial Meeting Preprints*, vol. 1, pp. 58-65.
- 9 It has been suggested to me that sexism was the problem; however, in Maputo there is gender equality in the workplace and many of the senior staff at the museum, including the director, were women. Nepotism has been identified as a problem in many developing countries, putting people into jobs who are not interested in doing them but who cannot be

sacked for poor performance; however, this did not appear to be a problem at the museum in Mozambique, where the senior staff were all well qualified for their jobs. Low pay was a factor in the guards' reluctance to help me; like many foreigners working in Mozambique, I was on a generous grant while they were on pitifully small local salaries, a situation which compounded their resentment towards me.

- 10 Low pay was the problem here. Absence of staff was tolerated as many were busy with second jobs to supplement their tiny incomes - one of the conservators spent time producing bus destination signs using the computer and printing facilities at the museum.
- 11 The 'donation' of out-of-date drugs to developing countries is an example of the phenomenon from another sector.
- 12 The use of dataloggers to give complete and accurate readings of the environment was suggested to me. These are relatively cheap but would still have represented a very significant outlay for the conservation department at the museum. Part of my aim was to persuade the museum's conservators that effective conservation work could be carried out using the resources already available to them, since they were paralysed into inaction by the idea that all conservation work requires money. For this reason I wanted to stick to using the museum's equipment rather than buying or borrowing dataloggers from elsewhere.
- 13 Colleagues in Durban suggested the paint used for road markings as a cheap and effective moisture barrier. This solution needs further investigation.
- 14 Gael de Guichen (ICCRUM) and John Dean (Cornell University), amongst others, have been very helpful in discussing the topics covered in this paper with me.
- 15 Barclay R L & Antomarchi C. 1994. PREMA: A Conservation Strategy for African Museums. In Preventive Conservation: Practice, Theory and Research. IIC, pp. 61-64.
- 16 The Museum Studies Centre in Jos, Nigeria and the Ecole du Patrimoine Africain in Porto-Novo, Benin are two examples.
- 17 Staniforth S. 2006. Relative Humidity as an Agent of Deterioration. In The National Trust Manual of Housekeeping. Butterworth-Heinemann, p. 113; Dean J. 2005. Passive Climate Control: Sustainable Building. Cornell University, and Staniforth S, Hayes B & Bullock L. 1994. Appropriate Technologies for Relative Humidity Control for Museum Collections

Housed in Historic Buildings. In Preventive Conservation Practice, Theory and Research. IIC, pp. 123-128.



This work is licensed under a Creative Commons Attribution - Noncommercial - No Derivative Works 3.0 Licence.

THE ROLE OF AIR EXCHANGE RATE AND SURFACE REACTION RATES ON THE AIR QUALITY IN MUSEUM STORAGE BUILDINGS

MORTEN RYHL-SVENDSEN

ABSTRACT

Museum storage buildings often have low air exchange rates. For such buildings, the indoor level of air pollution is primarily dependent on the air exchange rate, and the sorption capacity of indoor surfaces. This paper illustrates the effect of the air exchange and the sorption reactions, as well as mechanical ventilation with active filtration, by using data from pollution measurements in three Danish museum and archive buildings. Typically indoor ozone levels will increase when the air exchange rate increases, as ozone enters buildings from outside. Pollutants generated indoors, such as organic acids, will dilute in concentration as the air exchange rate increases. However, the source strength and the surface sorption capacity are dominating influences when the air exchange rate is below about 1 h⁻¹. Active filtration is an efficient method for pollution removal, especially by internal re-circulation units.

INTRODUCTION

Many museum storage facilities are located in buildings with little human activity; there are usually no permanent work places within the storage areas, and they are only visited when an object is picked up or delivered back. For the rest of the time the room or entire building is kept closed, which results in very stagnant conditions for the indoor environment. If the building lacks mechanical ventilation there can be very little exchange between the rooms and the ambient air. This will retard outdoor air from entering collection area, but will allow internally generated compounds to accumulate inside the rooms.

AIR POLLUTANTS AND MATERIAL DAMAGE

Gaseous air pollutants attack materials by chemical reactions: some by acid hydrolysis (e.g. acetic acid), and others by direct oxidation (e.g. ozone). The more pollutant that is available to be deposited on an object, the faster the reaction. Some pollutants acts in synergy, and also the interplay between

pollutants and moisture is an important factor in deterioration processes such as hydrolysis. The main deterioration effect from particulates is soiling, which especially is a problem with the fine fraction (<1µm diameter). The key pollutants causing material damage include ozone, oxides of nitrogen, oxides of sulphur, reduced sulphur gases, organic acids, and fine particles. Ozone, nitrogen oxides, and sulphur oxides originate entirely from outdoor sources. Reduced sulphur gases may have both outdoor and indoor sources, whereas organic acids in any significant level are generated indoors. Fine particles may have sources both outdoors and indoors; however, their chemical content may differ. A general introduction to air pollution in museum environments is given, for example, in [1-4].

POLLUTION CONTROL IN BUILDINGS

The leakier a building is, the more air pollutants will infiltrate from outdoors. This is especially true for large, open-plan buildings, such as museum galleries. In such buildings the indoor level of outdoor-generated pollutants will typically be in the range of 30-80% of the outdoor concentration.

At the other extreme, indoor-generated pollutants are especially abundant in small, confined air volumes such as display cases, safes, and storage cabinets. With an almost airtight room made from polluting materials, the pollutants which are generated inside cannot escape and the concentration can reach a very high level. If it doesn't, there must be fast reaction with the stored treasures. Somewhere between the open gallery building and the display-case we have storage and archive buildings. Climate control for such buildings is focussed mainly on the relative humidity (RH); on avoiding extremes of dry or humid conditions, and minimizing the amplitude of RH variations.

Traditionally, climate control in buildings is carried out by mechanical means using heating, ventilation and air-conditioning systems. Such systems can be equipped with filters for gaseous and particulate pollution. However, recently there has been increased focus on passively climatized

buildings, where the building materials and structure contribute temperature and humidity stability. To obtain the highest buffering effect, such buildings must be relatively airtight, which is fine for storage buildings without human comfort requirements (no need for a constant intake of “fresh” air). Such storage facilities can have an air exchange rate of 0.5 h⁻¹ or less, driven by natural ventilation only. See for example [5] in this publication. However, what this means for the air quality is not clear, as so far only few investigations have been conducted in museum buildings with low air exchange rates.

This paper describes different factors which define the air quality inside museum storage buildings. Results from air quality monitoring in three Danish museum and archive buildings are used to illustrate this. This monitoring was carried out in storage rooms within the National Museum of Denmark, the Danish Museum for Photographic Art, and the Arnamagnæan Institute’s archive at Copenhagen University. These locations were used for an investigation of different ventilation strategies for museum storage buildings, which will be published in full elsewhere [6]. More than 20 three-month monitoring campaigns were carried out at 11 locations within the three buildings. Some locations had two or more measurement periods following each other but under different ventilation conditions. The storage rooms ranged in volume between about 120 and 500 m³, and most had low air exchange rates (<0.5 h⁻¹) although this was changed for some of the measuring periods. Most of the locations had no mechanical ventilation. The rooms were highly loaded with furniture and collection objects; typically the surface-to-volume ratio was about 4 m²/m³.

METHODS

Air pollutants were measured at all locations by passive sampling. Organic acids (formic + acetic) were sampled using a Palme’s diffusion tube sampler system provided by Oxford Brookes University. Ozone was sampled using the Analyst diffusive sampler system, provided by the Italian Institute for Atmospheric Pollution CNR-IIA. The reported pollution concentrations, or the I/O ratios based on pollution measurements, are three month average values.

Particles were measured as the concentration of ultrafine particle in air (0.02-1 µm diameter) using a TSI P-Trak Particle Counter. The particle count was taken once per minute during a 6-8 hour period.

The air exchange rates were determined by measuring the concentration decay rate of a tracer gas (freon 134a) at one minute intervals during a one hour period, using a photo-acoustic sensor (Innova Multigas Monitor 1302).

Both indoor and outdoor conditions were measured at all sites. The indoor monitoring apparatus was set up near the centre of each room. The outdoor environment was monitored at the National Museum from a Stevenson Screen located on a lawn near the building, and for the two other buildings from rooftop weather stations.

INDOOR/OUTDOOR POLLUTION RELATIONS

Air pollutants from outdoors will infiltrate buildings through holes or cracks in the building envelope, through open windows, or via the ventilation system. During the infiltration process the pollutants will deposit on surfaces that the air flow passes, thus constantly reducing their concentration. Ozone is an example of a highly reactive compound, which normally will be much reduced indoors compared to outdoors. Typical indoor/outdoor ratios (I/O) for ozone are below about 0.3, although I/O ratios as high as 0.8 have been reported in museum buildings [7,8].

When such sorption reactions are the dominant pollution removal factor, then the steady-state I/O relation of ozone (and of other outdoor pollutants) can be described by the deposition mass balance [9]:

$$\frac{I}{O} = \frac{n}{n + v_d \left(\frac{S}{V} \right)} \quad (1)$$

Where:

- I = indoor concentration of pollutant [ppb or µgm⁻³]
- O = outdoor concentration of pollutant [ppb or µgm⁻³]
- n = air exchange rate [h⁻¹]
- v_d = deposition velocity [mh⁻¹]
- S = inside surface area of room [m²]
- V = volume of room [m³]

The surface removal rate $v_d(S/V)$ is a central factor of expression 1. This removal rate is defined as the deposition velocity of a pollutant times the surface-to-volume ratio of the room. The deposition velocity is defined as the flux of a pollutant to a surface

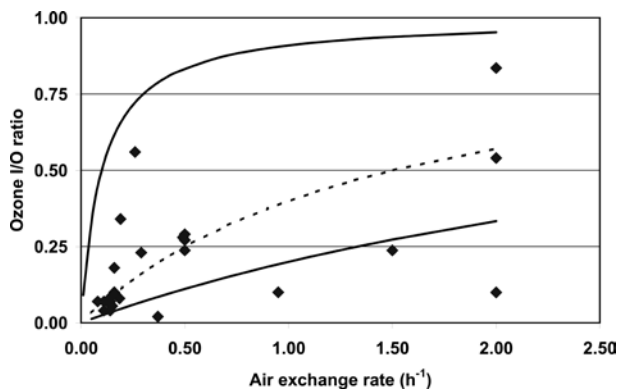

Figure 1. The indoor/outdoor ratio for ozone at different air exchange rates. The relation is modelled for three different environments: a highly reactive room with the ozone surface removal rate of 4 h^{-1} (low curve), a normal room with the ozone surface removal rate of 1.5 h^{-1} (dotted curve), and a slightly reactive room with the surface removal rate of 0.1 h^{-1} (upper curve). The data points represent measurements from real museum stores.

divided by its concentration in air, which gives it the unit of velocity. For highly reactive pollutants such as ozone, removal by surface reaction, rather than reaction in the air, is a significant part of the total pollution loss indoors. The surface removal rate is directly comparable to the air exchange rate: if, for example, a room has the surface removal rate of 1 h^{-1} , then pollutants will deposit on the indoor surfaces in a rate equal to what would be ventilated away at one air changes per hour.

Fig. 1 shows how the air exchange rate and the surface removal rate will influence the I/O ratio of ozone within a building, based on equation 1. A typical room with an ozone removal rate of 1.5 h^{-1} is illustrated by a broken line. The model lines are compared with 25 measurements from different museum stores. A few measurements falls outside the area defined by the model lines (which indicates normal indoor environments); however, these specific measurements are from locations where extra control measures such as air filters were installed. Fig. 1 shows that the most efficient way to retard outdoors pollutants from infiltration is a combination of a low air exchange rate and a high surface removal rate.

INDOOR POLLUTION GENERATION

For compounds which are released to the environment indoors, as emission from building materials and even the collection itself, the steady state concentration inside a building is dependent on both the air exchange rate, and the re-sorption onto the interior surfaces. In general; the higher the

air exchange rate, the lower the concentration of indoor generated pollutants.

A mass balance similar to that of equation 1 can be expressed for indoor generated pollutants (assuming the outdoor concentration = 0):

$$I = \frac{\left(\frac{G}{V}\right)}{n + v_d \left(\frac{S}{V}\right)} \quad (2)$$

Where: G = generation rate of pollutant [$\mu\text{g}/\text{h}$]

Fig. 2 shows how the air exchange rate and the surface removal rate will influence the indoor concentration of a pollutant which is generated inside a building (assuming a constant generation rate of pollutants).

A typical room with an organic acid removal rate of 0.5 h^{-1} is illustrated with the dotted line. The 16 data points represent measurements of organic acid concentrations (the sum of acetic and formic acid) from different museum stores. We see that both an increase in air exchange or in the surface removal rate will lower the pollution concentration, however, the surface removal rate is the dominant factor when the air exchanges is below about 1 h^{-1} , while at higher air exchanges it is mainly the air exchange rate which controls the pollution concentration. Note that internally generated pollution can have a much higher concentration within a porous object, such as a book, than in the free air space of the room,

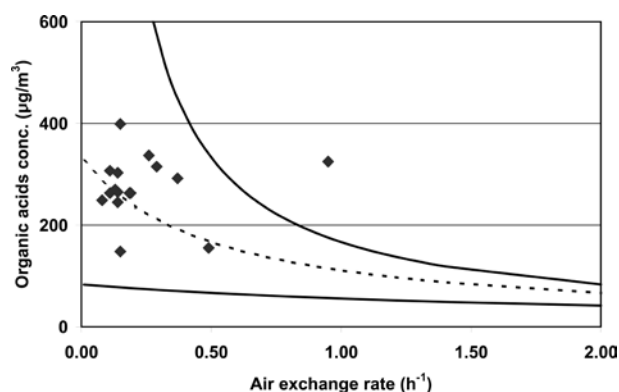

Figure 2. The concentration of organic acids ($\mu\text{g}/\text{m}^3$) at different air exchange rates, modelled for a 120 m^3 room. The internal emission of organic acids – emission from furniture, building materials, or the collection itself - is assumed constant at $20 \text{ mg}/\text{h}$. The relation is modelled for three different environments: a highly reactive room with the acid surface removal rate of 2 h^{-1} (low curve), a normal room with the acid surface removal rate of 0.5 h^{-1} (dotted curve), and a room with no surface removal at all (upper curve). For the latter model ventilation is the only removal mechanism. The single data points represent measurements from real museum stores similar to the model room.

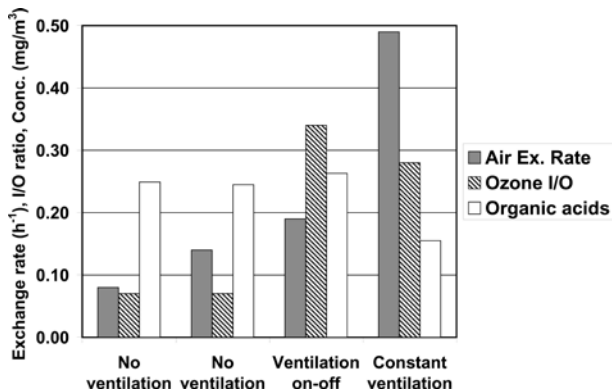

Figure 3. The air exchange (h^{-1}), ozone indoor/outdoor ratio, and organic acids concentration (mg/m^3) for four different monitoring periods at the Arnamagnæan Institute's archive with four different ventilation rates.

whereas pollution coming from outside will always have a higher concentration in the air space than in the pore spaces of the book.

The desire to keep a low air exchange rate for a building in order to maintain a stable indoor climate may conflict with the need to keep a clean air quality if emissive materials are present in the room. The use of 'passive sorption' where the air pollutants are re-sorbed onto walls will only work to the rate of 2, maybe 3 h^{-1} , for normal rooms. Instead an efficient way to further increase the rate of pollution removal is by the use of filter units, through which the room air is constantly re-circulated.

THE EFFECT OF AIR EXCHANGE

The relation between the rate of air exchange and pollution levels is illustrated in fig. 3, using measurements from the Arnamagnæan Institute's archive as an example. The trend for the ozone I/O ratio is that it increases when the air exchange increases. On the other hand; the internal generated organic acids were only significantly decreased in concentration when the ventilation was constantly on. For the organic acids it would have been expected that a more significant concentration decrease would take place as the air exchange rate increased. However, this is based on the assumption that the acid emission was constant over time, which it maybe in fact was not.

Also, particles do infiltrate buildings from outdoors, and are being reduced in concentration on their route indoors due to deposition on surfaces. Fig. 4 shows ultrafine particle measurements from a storage room during half a day. The indoor particle concentration followed the outdoor particle concentration closely, constantly keeping the I/O ratio at about 0.25. For

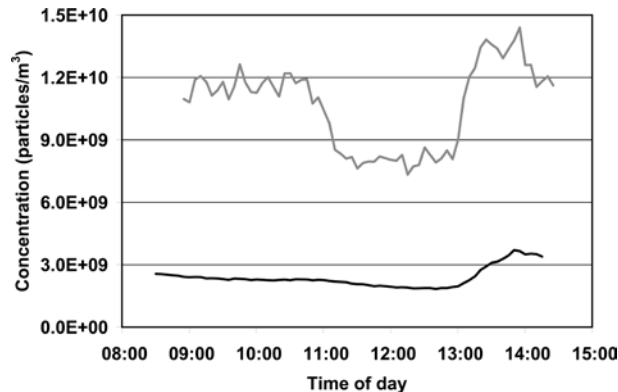

Figure 4. The concentration of ultrafine particles outdoors (grey upper curve) and inside a storage room (black low curve).

this example the air exchange rate was about 1 h^{-1} , so according to equation 1 the surface removal rate for particles was then 3 h^{-1} .

THE EFFECT OF SORPTION

As fig. 1 and 2 suggest, the amount of reactive surface available inside a room is one of the main means of pollution removal at low air exchange rates. It can, however, be difficult to add enough extra wall surfaces into a normal room without disturbing the original functions of the room, such as providing storage space for collection items. One way to get around this is to use ventilation filters, which are constructed so that they expose a large surface area within a relatively small volume. The air is forced to pass through the filter media by a mechanical fan, rather than by passively diffusing to the wall surfaces. This ensures that large volumes of air are being filtered at a high rate. Fig. 5 show how the ozone I/O ratio for the Photographic Museum archive was lowered by passive sorption onto

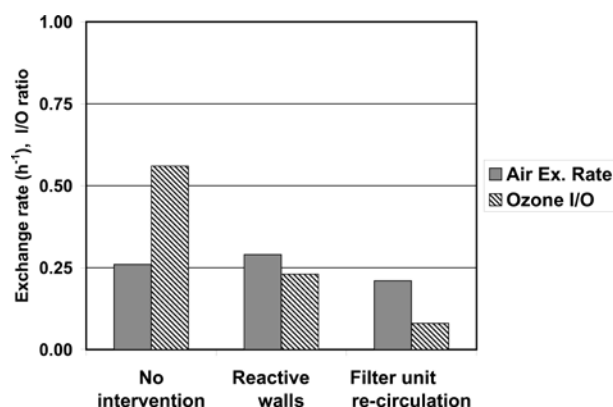

Figure 5. The ozone indoor/outdoor ratio for the Photo Museum archive. The I/O ratio was measured during three different situations: For the room itself without any control measures (left), with reactive wall paper (centre), and with a re-circulating filter unit (right). The reactive paper was from MicroChamber® with a core of activated carbon. 102 m² of paper was used inside the 158 m³ archive. The filter unit (Kemfilter Maximus 700) re-circulated the room air at a rate of 3.7 room volumes per hour.

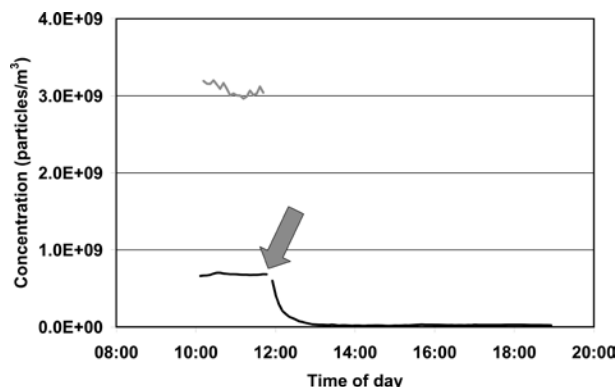

Figure 6. The concentration of ultrafine particles outdoors (grey upper curve) and inside (black low curve). The arrow points to the time when a re-circulation filter unit inside the room was turned on (Kemfilter Maximus 700).

reactive wall paper, but was even better removed when the air inside the archive was constantly being re-circulated through an internal filter unit. During the three measurement periods the air exchange rate was more or less uniform, so the indoor decrease in ozone must primarily be attributed to the increased amount of reactive surface materials inside the archive, either as the reactive wall paper, or the filter media inside the re-circulation unit. For the room alone the surface removal rate was about 0.2 h^{-1} , which was comparable to the air exchange rate, indicating negligible absorption by the walls and furniture. The reactive wall paper raised the surface removal rate to 1.0 h^{-1} , and the filter unit to 2.4 h^{-1} – more than 10 times the removal rate of the room alone.

The recirculation unit was equipped with filters both for gaseous pollutants and ultrafine particles. Fig. 6 show how effective the internal recirculation was on the particle level; within 90 min from activating the re-circulation unit the particle I/O ratio fell from 0.23 to 0.01, and this ratio was maintained during a three month test period.

THE EFFECT OF VENTILATION

Ventilation with ‘fresh’ air, where outdoor air is taken inside by the force of a mechanical fan is commonly used also in museum buildings. Based on equation 1 it is clear that by increasing the ventilation rate the inflow of air pollutants will also increase, unless a filter is used. For a fresh air ventilation system these filters must be placed in the incoming air stream. However, if the main reason for choosing mechanical ventilation for a storage room is to control the air pollution [10] then care must be taken that the chosen filters remove all air pollution. Fig. 7 illustrates this point: In a storage

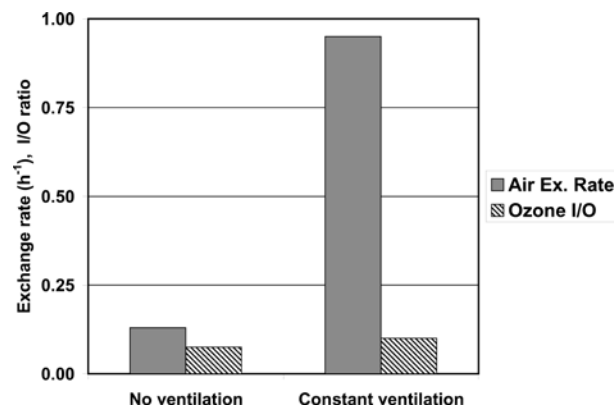

Figure 7. The ozone indoor/outdoor ratio for a storage room at the National Museum. The I/O ratio was measured during a low (left) and a higher (right) air exchange rate. The higher air exchange rate was forced by the use of a fan, pressing the air through a carbon filter.

room with no mechanical ventilation and a low natural air exchange rate of about 0.1 h^{-1} the ozone I/O ratio was 0.08. When a ventilation system with a carbon filter was installed the air exchange rate was forced up to almost 1 h^{-1} , however the I/O ratio remained almost unchanged at 0.10.

What happened here was that while the filter did remove a large amount of ozone from the air, the total mass of air which was forced through the room was also increased. The surface removal rate while no ventilation took place was about 1.6 h^{-1} , according to equation 1. When the fan and filter was installed the total removal rate (of room + filter) became much higher, 12 h^{-1} , which reflects that the filter did indeed remove a lot of ozone. However, the net result for the environment inside the room was unchanged, and the collection was still exposed to the same level of ozone.

SUMMARY

Surface reactions are the main destruction mechanism for air pollutants. Keeping in mind that surface deposition on the collection items is part of the deterioration route for these objects, it is important to keep as much ‘sacrificial’ surface material as possible (on walls, or in filters) compared to the surface area of the collection itself. Passive surface removal, by the use of reactive wall paper, can provide a surface removal rate equal to the pollution dilution provided by several air exchanges per hour, however, by the help of mechanical filter units this can be increased by a factor of 10. A building, which has a low exchange rate with the ambient air combined with an internal active pollution control, will provide a high degree of protection from pollutants in air coming from both outside and inside the room.

ACKNOWLEDGEMENTS

The help and support which was received from the management and staff at the National Museum of Denmark, the Danish Museum for Photographic Art, and the Arnamagnæan Institute at Copenhagen University is highly appreciated.

The re-circulation filter unit was provided free of charge by Kemfilter AB, Söderhamn, Sweden.

The air pollution sampling was supported financially by Beckett Fonden, Denmark.

This work was part of a PhD project financed by the School of Conservation, Royal Danish Academy of Fine Arts, and carried out in co-operation with the International Centre of Indoor Environment and Energy at the Technical University of Denmark.

AUTHOR

Morten Ryhl-Svendsen
The National Museum of Denmark
Department of Conservation
IC Modewegsvej, Brede,
DK-2800 Kgs. Lyngby
morten.ryhl-svendsen@natmus.dk

REFERENCES AND NOTES

- 1 Baer, N.S., and Banks, P.N., 'Indoor air pollution: effects on cultural and historic materials', *The International Journal of Museum Management and Curatorship* **4** (1985) 9–20.
- 2 Graedel, T.E., and McGill, R., 'Degradation of materials in the atmosphere', *Environmental Science and Technology* **20** (1986) 1093–1100.
- 3 Brimblecombe, P., 'The composition of museum atmospheres', *Atmospheric Environment* **24B** (1990) 1–8.
- 4 Tétreault, J., *Airborne Pollutants in Museums, Galleries and Archives: Risk Assessment, Control Strategies and Preservation Management*, Canadian Conservation Institute (CCI), Ottawa (2003).
- 5 Padfield, T., Larsen, P.K., Jensen, L.A., and Ryhl-Svendsen, M.: The potential and limits for passive air conditioning of museums, stores and archives, *In this publication* (2007).

- 6 Ryhl-Svendsen, M., and Clausen, G.: An intervention study examining the effect of ventilation, filtration and passive sorption on indoor air quality in museum storage rooms, *To be submitted to: Studies in Conservation* (2007).
- 7 Weschler, C.J., 'Ozone in indoor environments: concentration and chemistry', *Indoor Air* **10** (2000) 269–288.
- 8 Ryhl-Svendsen, M., Indoor air pollution in museums: prediction models and control strategies, *Reviews in Conservation* **7** (2006), 21–41.
- 9 Weschler, C.J., Shields, H.C., and Naik, D.V., 'Indoor ozone exposures', *Journal of the Air Pollution Control Association* **39** (1989) 1562–1568.
- 10 There may be other reasons for choosing mechanical ventilation, for example; human comfort.



This work is licensed under a Creative Commons Attribution - Noncommercial - No Derivative Works 3.0 Licence.

Session 5

The showcase and the picture frame

THE EVOLUTION OF A CONSERVATION FRAMING POLICY AT TATE

STEPHEN HACKNEY

ABSTRACT

Using glazing for protecting paintings has a long history and this has been developed into a frame microclimate system that has been applied to much of the collection at Tate. The paper describes the evolution and rationale for this approach, analysing the risks addressed and assessing the benefits and shortcomings.

The principal function of a frame is to distinguish the space depicted by the artist from that of the surrounding room. A frame is a museum object in its own right, its design inevitably representing contemporary fashion. But it was soon recognised that a frame also provides physical protection for the painting it houses. It protects the painting from excessive interference and allows handling without direct contact with the painting. In the sixteenth century, portrait miniatures were also protected by glass. By the nineteenth century the museum frame with removable glazing and cloth backing demonstrated a considered and practical solution to the conservation needs of a painting.

Gradual industrialisation from the sixteenth century, accelerating during the eighteenth and nineteenth centuries, created air pollution throughout all urban areas. The use of coal for power generation, kilns and smelting in industrial cities and for domestic heating in London had a major impact [1]. As a result, the exteriors of buildings became coated with black deposits and sulphates. Most buildings were well ventilated by modern standards, being designed for the burning of coal in open fires, and exterior pollution readily found its way in. Clothes, furnishings, fabrics, wallpapers and any absorbent decorative material would need regular dusting and washing. Silver and copper alloys needed regular cleaning and polishing. In a large household, servants worked ceaselessly to keep everything clean. Wherever possible some form of protection was applied to surfaces. All paintings would have had a coating of mastic varnish applied to allow them to be dusted regularly and surface-washed occasionally. By the mid-nineteenth century copal

resin was recommended to protect pigments in oil paint from being attacked by polluted air [2].

Despite this unpromising atmosphere, such was the interest in art from the mid eighteenth century, as expressed through attendance at exhibitions and academies, that the display of vulnerable old master and contemporary drawings, prints, pastels and watercolours became popular [3], by removing these works from portfolios, mounting and framing and glazing them. Cylinder glass was manufactured in large enough sheets to make window glass of sufficient size to satisfy the architectural needs of the enlightenment. Polished glass, manufactured using mechanical abrasive and polishing techniques, was highly valued and suitable for mirrors. Such methods of manufacture were not revolutionary; instead they reflect the development and perfection of difficult traditional manufacturing processes and mechanisation using cheap coal power, which continue today.

In 1850 Eastlake, Faraday and Russell proposed that glazing be applied to oil paintings on permanent display at the National Gallery [4]. In the select committee report of 1853, the keeper, Sir Charles Eastlake, was questioned on why little progress on glazing had been made. His reply was ambivalent, emphasising the disadvantage of reduced visibility (from reflections) yet re-affirming his conviction of the protection afforded [5]. This constituted the central dilemma: the recognised need to exclude pollution in conflict with significant interference with display. Ominously, the perception of this dilemma depends on the needs of the individual viewer. Artists had special viewing rights, for copying, free from the interference of the crowds and Eastlake considered the use of removable glazing to permit temporary viewing. Much of the enquiry dealt with removal of varnishes and sites for a new gallery in a less polluted location. A new gallery was never built and glazing remained the only option.

External pollution was not the only problem, the enthusiastic attentions of the public involved significant risk, from pointing, sneezing and spillage, and this would not be solved by relocation.



Figure 1. A nineteenth century gallery frame on a J.M.W. Turner painting (*Sketch for East Cowes Castle, the Regatta Beating to Windward, no2, 1827, Tate N01994*). The inset door allows glazing to be removed. © Tate, London 2007

A further recommendation by Faraday and Russell had been the application of backings. Because paintings were tilted for better viewing their backs were exposed to considerable dust deposition. In the 1853 report, Segurier suggested that tightly woven stretched textile be applied to the backs of frames as a dust seal. A trustee, Colonel Thwaites, expressed a concern that air should not be excluded from the canvases for fear of creating a hazard, presumably mould growth.

Following such procedures the painting is entirely enclosed. Russell, by his own admission, had not been considering the backs of paintings sufficiently but he had made glazed boxes to enclose entire paintings (and frames). Faraday was clear on the effects of enclosure, stating categorically that enclosure would not harm a painting, and distinguishing enclosure from hermetic sealing. He compares the seal of a frame enclosure with that on a Ward's case, a very successful design to transport plant specimens on long sea journeys. This is the first intimation of a microclimate. Following the 1853 report cloth backings were generally introduced (fig. 1).

The following period saw fundamental changes in art that would lead many artists to reject framing. At its height the concept of 'finish' was essential to any painting exhibited by serious artists, such as academicians. Finish involved a high level of obvious workmanship and detail, and even included an overall shiny varnish. Whistler was accused by Ruskin of having fallen below this standard, yet Whistler took great care to design individual frames and to consider the presentation of his work in context. His contemporaries in France at the *Salon des Refusés* challenged the establishment more



Figure 2. An unvarnished oil painted relief by Ceri Richards (*Two Females, 1937-8, Tate T00307*) which cannot be protected on display and has accumulated considerable dirt particularly on the top of horizontal surfaces. © The estate of Ceri Richards

fundamentally. Impressionism rejected varnish and finish. There had always been paintings that were much too big to glaze: a concern for surface absorbency, texture and large scale led artists to emphasise the virtues of mural painting. Later cubists and abstractionists rejected completion of the picture space and the depiction of perspective that had been in use since the Renaissance. Malevich talked of a suprematist painting as an object with an existence unrelated to the depiction of another event and architectonics transmuted painting into a third dimension. More prosaically many artists simply regarded the frame as an expensive afterthought that could only detract from a painting, or simply be left to the dealer or new owner. Such frames have since been considered to be 'not original'.

Modernist architects sought more light in their buildings, incorporating large windows, new lighting technology and painting walls in lighter colours. The challenge of minimising the use of material extended to furniture and frames. Not only did contemporary artists no longer want frames for their work but exhibition designers wanted to put traditional paintings in modern settings. Older frames looked dark and unfashionable and reflections from glazing that had been reluctantly accepted on sky-lit deeply coloured Victorian walls presented serious glare in modern ambiently lit galleries. Glazing had to go and dirty old frames needed to be re-gilded, or even removed and sometimes replaced by more fashionable versions.

The Tate Gallery Conservation department was established in 1956, initially to restore major paintings, but later to survey the collection. Evidence emerged of traditional paintings neglected

since acquisition and contemporary works of art in good condition but also at direct risk from museum activity and longer term deterioration (fig. 2).

In 1967 the London Conference on Museum Climatology addressed the subject of the protection of works of art on display, providing important technical information [6, 7, 8, 9]. Rapid changes in relative humidity were thought to be important agents of damage: certainly the evidence of damage from very low winter humidity in the form of paint flaking from panels and from canvases with old glue linings was frequently observed. Air conditioning was installed at the National Gallery and in the 1979 extension at Tate. But most of the Tate Gallery remained unconditioned, and portable humidifiers had only limited effect in an unsealed building.

In response to the needs of a contemporary collection the concept of preventive conservation was easy to establish at Tate. A policy of examining and protecting new acquisitions had clear benefits, but required an understanding of deterioration and means of prevention. The lessons learned in 1850 were still relevant and could be revived to fit new circumstances, but needed to be applied in a way that was acceptable for the display of a collection that included a wide variety of paintings.

Beginning with the basics, a strong frame is essential for the physical protection of both frame and painting and incidentally is also a requirement for the application of a backboard [10]. Frames are often weakest at their mitred joint corners. They are strengthened by adding to the reverse a wooden build-up that overlaps the corners and provides rigidity. Together these elements provide a rigid structural box.

Backboards became a mainstay of conservation policy. Since they are not seen, there are few constraints on their application and backboards have been applied to all paintings in the collection [11]. If rigid backboards are used, they can protect from impacts from the reverse during handling. Even unframed or minimally framed paintings can have a backboard applied to their stretcher or to a special transit/handling frame to provide similar protection. Backboards can also be dust seals and impermeable moisture barriers. Earlier cloth backings were replaced with hardboard backboards with ventilation vents. Measurements were carried out on the permeability of backboards [12]. As a result oil-tempered hardboard backboards, which

were well sealed with screws and tape, were adopted in order to reduce significantly moisture transfer.

In conjunction with glazing, the effectiveness of backboards proved to be much better than expected. Simple seals and moisture barriers created extremely stable relative humidity (RH) conditions within frames, which could be measured by newly available RH/T data loggers. It became apparent that it was the self-buffering of the enclosed space by the hygroscopic materials of the work of art and frame themselves that caused stability. The RH remained constant as long as moisture leakage from the frame was less than the rate of transport through the wood, glue or canvas and evaporation from their surfaces [13]. Because the quantity of water supported by the air is very small any lost air took with it very small quantities of water.

We measure RH of air because it tells us about the moisture content of the work of art in equilibrium with it [14]. The rate of moisture exchange between a work of art and its environment may be very low, particularly for a thick wooden panel. A panel's moisture content changes very slowly and is independent of short term fluctuations in RH. Provided its temperature is kept in the range for human comfort, a glazed and backboarded panel can be hung in unconditioned galleries without any damage and with only minor seasonal changes in moisture content. Even air-conditioning systems cannot match the stability or reliability of enclosures.

This backboard and glazing design, later modified with an inner polyester film, has been used at Tate for 30 years, allowing works of art to be stored, exhibited in different galleries and loaned (fig. 3). It is difficult to attribute with certainty any damage

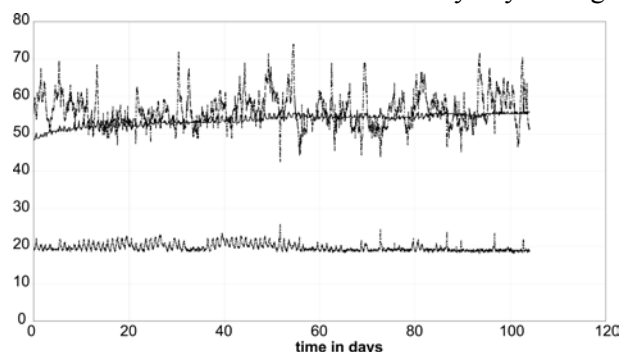

Figure 3. Graph showing the relative humidity and temperature inside and outside a framed, glazed and back-boarded oil painting on stretched canvas kept in an unconditioned gallery at Tate Britain (Tate) at a temperature around 20°C (lowest line on graph). The stability of RH inside a frame (the continuous line) is well documented.

to specific causes, but the low level of observed damage contrasts with previous experience. There are also benefits for paintings that cannot be glazed. The variation of a backboard/canvas microclimate depends on transport through the front of the enclosure and this depends on the nature of the painted surface and varnish.

Sulphur dioxide pollution measurements indicated that good seals could prevent the ingress of pollution. Even in polluted conditions, levels inside a frame enclosure are negligible, suggesting that little penetration occurs [15]. In order to test this, in 1980, linen canvas samples that had been kept in the gallery conditions for 24 years, some in enclosed containers, were examined in detail. Strong evidence emerged of protection afforded by enclosure. The colour, dirt deposition, pH and strength of enclosed samples remained significantly better than exposed canvases [16]. This related to the polluted conditions during the period.

The application of glazing to the front of a painting, for mechanical, chemical and hygroscopic reasons, is key to the provision of a microclimate. Fortunately the reflection problem has a solution, which has allowed the conservation benefits of microenvironments to be realised [17]. Low-reflecting glass cuts reflections significantly to one or two percent and if lit carefully can avoid inevitable green or purple fringes being noticeable from most angles. Over a period of years, as low reflecting glass has become more affordable, it has been introduced into framing practice. With nineteenth century frames this has been simple to implement, providing obvious benefits, even to those initially reluctant to accept glazing. Low reflecting glazing can also be applied to many earlier frames, but can visually spoil some elaborately carved lightweight frames. Early twentieth century frames can often accommodate glazing but unframed works present a problem. Where the surface is obviously vulnerable, such as exposed canvas, unvarnished paint or impasted surfaces, display vitrines can be used. A simple glass or acrylic box with a solid plywood backboard, preferably painted the same colour as the gallery wall, can look acceptable, especially when kept thin and wide so that it is visually well separated from the painting.

For lighter coloured objects, often works on paper, the reflections from acrylic are masked by the high general reflection, and are frequently accepted, but for dark objects in light galleries the reflections are unacceptable. As low reflecting glass has found its way into many museum collections, the reflections

from acrylic and even ordinary glass are no longer considered acceptable for display. Low reflecting acrylic sheeting with a scratch resistant surface is now available but remains very expensive.

Glass is a brittle material. Risk analysis of the breakage problem has allowed simple and reliable procedures for the safe handling and transport of glazed paintings to be developed [18, 19]. This has allowed us to combine better display with improved conservation within an economic framework required by the huge expansion of display activity at Tate. The availability of low reflecting glass, the application of the principles of preventive conservation, risk analysis, a systematic working environment and an engaged pre-emptive approach to the needs of display are all necessary to achieve this result.

The benefit of consistent procedures for fitting glass and strengthening frames over many years provided confidence that taping was not necessary to protect a painting if the glass broke. We therefore ceased to tape glass for Tate works. We cannot extend this rule to works brought in on loan since we are not always certain of the rigidity of their frames or the fitting and age of the glass and we were aware that some lenders would expect their glass to be taped. We were comfortable with our risk analysis to a maximum size of glazing around one square metre. Since we have not tested larger pieces we specify that any glazing of larger paintings is done with laminated glass. But as laminated glass becomes more affordable we may extend its use to all glazed paintings.

We also concluded that the use of acrylic glazing confers no advantages and, since it is unacceptable for display of many paintings, it is no longer used for loans. This prevents extra handling to change glazing and disturbance to the painting. It also avoids other drawbacks of acrylics, such as their tendency to develop an electrical charge leading to dust deposition and sometimes transfer of unbound pigment from a painting surface and their susceptibility to abrasion. Where the frame is relatively flexible, acrylic is still used, for example, on works of art on paper which are predominantly white paper and much less susceptible to reflections.

Wherever possible, the principle of the microenvironment was extended to unframed and unglazed paintings too. Transit frames are made for unframed modern paintings to protect them during handling and transport (fig. 4). These frames are wrapped in polyethene film to isolate the paintings from their environment [20]. The same frames are



Figure 4. An unvarnished painting with a vulnerable surface protected when off display, during handling, storage and transit, by an L-section frame wrapped in polythene. The reverse is protected by a backboard either attached to the storage/transit frame or to the painting stretcher.

used for storage, with the wrapping left in place. A backboard is attached to the stretcher or the transit frame to provide physical protection for the rear. The space between the painting and the backboard is a microenvironment. Its stability depends on the paint film. An acrylic film is a poor moisture barrier, whereas a varnished oil film is very much better. A varnished traditional oil painting in a heavy frame can provide almost as much RH stability as if it were glazed.

Internal pollution levels in frame enclosures remain to be studied. Two acids, acetic and formic, are produced by the degradation of various materials that may be enclosed [21]. Acetic acid is found naturally in certain woods, such as oak, or from the hydrolysis of man-made adhesives such as polyvinyl acetate. If the wood or adhesive is in close proximity to a work of art or is part of that work of art then acid build up is inevitable. Although the actual quantities available are very much less than for external pollutants, proximity and duration of exposure are important. A pollutant continuously generated at low levels and trapped within an enclosure will eventually cause noticeable damage. Similarly formic acid is generated by the degradation of adhesives, wood products such as MDF, resins such as phenol formaldehyde and urea formaldehyde. The precursors to these acids are formaldehyde or acetaldehyde, respectively, which then oxidise to the formic or acetic acids. Although the aldehydes have been measured and are an indicator of a problem, they may not be immediately damaging.

Other weaker organic acids generated by the degradation of natural resins and other organic material are also likely to be present. They have been studied less because their effect is likely to be masked by that of acetic and formic acids. Fatty acids from oils and amino acids from proteins may have a contribution to make to acid hydrolysis. For example degrading oil medium releases fatty acids to react with lead white pigment to create lead soaps, which increases the transparency of the paint and may give rise to protrusions. Sulphur dioxide from earlier pollution sorbed onto the surface of museum objects such as canvas or paper is likely to contribute to degradation which in turn releases more pollutant.

An interesting example is brown staining on the reverse of a painting by Morris Louis [22]. The unpainted cotton canvas has darkened most not at the extreme edges where the canvas is in good contact with the acidic wood of the stretcher but further into the canvas plane over the chamfered front surface of the stretcher and particularly where the wooden stretcher has an open joint between two sections of wood. This indicates that material is being given off by the stretcher but its ultimate effect does not simply depend on proximity. Whether the pollutant emitted is an aldehyde or a resin acid is not known but we could speculate that the degradation product, or emission, is transported by air currents and perhaps oxidised before it reacts. The need to understand such details reliably has become urgent for planning long-term storage in microenvironments. Louis's response was to paint the front of his stretcher (fig. 5)

The solution to chemical degradation is to introduce materials into the enclosure that absorb or neutralise acidity, oxidation or any other pollutant. This could either be applied directly to a work of art, say in the form of deacidification [23], or to control the quality of the gas inside. The introduction of chemicals is not likely to be reversible therefore we are reluctant to apply them directly to an object and, since their effect



Figure 5. The reverse of a painting on cotton duck removed from its stretcher revealing brown discoloration associated with the stretcher.

is preventive, we need to apply them to objects that are still in good condition. With any successful chemical control, the controlling agent is consumed and some method of identifying when it needs replenishing is required. But an enclosure provides a stable and measurable environment that enables us to prevent the most serious degradation reactions [24]. Since it is already our main tool it should be refined further to incorporate pollution scavengers and both the frame and painting should be treated appropriately before enclosure.

CONCLUSIONS

The frame microenvironment offers a unique conservation measure, combining physical and chemical protection. Further work is needed to ensure chemical stability.

AUTHOR

Stephen Hackney
Conservation Department - Tate
Tate Britain
Millbank
London SW1P 4RG
UK
stephen.hackney@tate.org.uk

REFERENCES

- 1 Peter Brimblecombe, *Air Composition and Chemistry*, 2nd edition, Cambridge University Press, 1996.
- 2 Joyce Townsend, Jacqueline Ridge and Stephen Hackney Ed., *Pre-Raphaelite Painting Techniques 1848-56*, pp 116, 2004, Tate Publishing ISBN 1 85437 498 2.
- 3 Smith G, Watercolourists and Watercolours at the Royal Academy, *Art on the Line: The Royal Academy at Somerset House 1780-1836*, ed. David H Solkin, 2001, The Paul Mellon Centre for Studies in British Art and Courtauld Institute of Art, pp189-200.
- 4 Eastlake, C.T., Faraday, M. and Russell, W., Report on the Protection by Glass of the Pictures in the National Gallery, House of Commons, 24 May 1850.
- 5 Report from the Select Committee on the National Gallery, Minutes of Evidence, ordered by the House of Commons, 4th August 1853.
- 6 Toishi, K, Humidity control in a closed package, *Studies in Conservation*, 4, 1959, pp 81-7.
- 7 Thomson G, Relative Humidity – variations with temperature of a case containing wood, *Studies in Conservation*, 9, 1964, pp153-69.
- 8 Padfield T, Control of Relative Humidity and Air pollution in Show Cases and Picture Frames, *Studies in Conservation*, 11, 1966, pp 8-30.
- 9 Stolow N, Controlled Environments for Works of Art in Transit, Butterworths London, 1966.
- 10 Booth P, 1996, The Tate's Approach to Conservation Framing, *The Picture Restorer*, No 10, Association of British Picture Restorers, 18-19.
- 11 Ridge J, The Tate Brand: its consequences fro the care and presentation of Tate collections, *The Object in Context: Crossing Conservation Boundaries*, ed. David Saunders, Joyce Townsend and Sally Woodcock, pp 23-29, IIC, 2006.
- 12 Hackney, S.J., 1990, Framing for Conservation at the Tate Gallery, *The Conservator*, No 14 , UKIC, 44-52.
- 13 Michalski S, 1994. 'Leakage prediction for buildings, cases, bags and bottles'. *Studies in Conservation*, 39 {3}: 169-186. London IIC.
- 14 Hackney S, The Dimensional Stability of paintings in Transit, *ICOM-CC 8th triennial meeting Sydney pre-prints*, 1987, pp 597-600.
- 15 Hackney S, 1984, The distribution of gaseous pollution within museums, *Studies in Conservation*, 29, 105-16.
- 16 Hackney, S. and Hedley, G., 1981, Measurement of ageing of linen canvas, *Studies in Conservation*, 26, 1-14.
- 17 Saunders, D, and Reeves, A., 1994, Protective Glass for Paintings, *National Gallery Technical Bulletin*, No 15, 98-103.
- 18 Green T, Hackney S and Perry R, Breaking Glass: Perception and Risk, *ICOM-CC 14th Triennial Meeting, The Hague preprints*, ed. I. Verger, 2005, pp 632-638.
- 19 Freemantle, R., 2003, Glazing Over: A Review of Glazing Options for Works of Art on Paper, *The Paper Conservator* 27, IPC, p 5-15.
- 20 Mecklenburg, M., (ed.), 1991, *Art in Transit: Studies in the transport of Paintings* National Gallery of Art, Washington.
- 21 Pamela B. Hatchfield, *Pollutants in the Museum Environment*, Archetype, 2002, ISBN 1 873 132 96 4.
- 22 Learner T and Crook J, *The Impact of Modern Paint*, Tate Publishing, 2000.

- 23 Hackney, S., Townsend, J., and Wyplosz, N.,
‘Studies on the Deacidification of Canvas
supports with magnesium methoxy carbonate’,
in Bridgeland, J., ed. *ICOM Committee
for Conservation, 11th Triennial Meeting,
Edinburgh pre-prints 1-6 September 1996*,
James and James, London, (1996) 271-5.
- 24 Lockett, K. and McKenzie, B. 2005. ‘Anoxic
framing investigations at Tate to date’. *Art on
Paper: Mounting and Housing*, Rayner, J.,
Kosek, J.M. and Christensen, B. [ed.] 67-74.
London: Archetype Publications.



This work is licensed under a Creative Commons Attribution - Noncommercial - No Derivative Works 3.0 Licence.

THE BENEFITS AND DISADVANTAGES OF ADDING SILICA GEL TO MICROCLIMATE PACKAGES FOR PANEL PAINTINGS

MERVIN RICHARD

ABSTRACT

Microclimate packages frequently are used for paintings exhibited in less-than-ideal environments. In order to minimize adverse effects caused by leakage, silica gel is added by some conservators to buffer the relative humidity. Concern has arisen that the difference between the adsorption properties of silica gel and the materials in panel paintings might cause damage during temperature changes. To evaluate this question, a research project was undertaken to study the behaviour of panel paintings in microclimate packages with silica gel and panel paintings in microclimate packages without silica gel, observing their dimensional behaviour during fluctuations in temperature. Various silica gels were tested. Additionally, panel paintings within microclimate packages were monitored with dataloggers while in shipment and on loan to other institutions. Results indicate that while silica gel is probably not necessary in well-designed and well-constructed packages, adding a moderate quantity of silica gel to microclimate packages used for panel paintings incurs no increased risks and may prove beneficial when a package has a higher than anticipated air exchange rate.

INTRODUCTION

The idea is not a new one—that of encasing paintings in sealed environments. [1] Many terms have been applied—clima-box, microclimate case, microclimate vitrine—but the designation presently used at the National Gallery of Art, Washington, is “microclimate package.” [2] In this paper, the term microclimate package refers to enclosures housing only the painting, containing relatively small quantities of air, and typically fitting within the frame rabbet.

A number of institutions have used microclimate packages routinely for panel paintings loaned to venues with less-than-ideal environments. Their value is so widely accepted that some conservators recommend them solely to minimize environmental fluctuations during transit, when in fact adequate protection can be provided by using well-insulated packing cases and by wrapping paintings in vapor

barrier materials, such as polyethylene. [3] But while microclimate packages have been used extensively, the inclusion of silica gel has been a subject of debate. This paper will address the benefits and disadvantages of employing silica gel in microclimate packages.

THERMAL RESPONSE OF PAINTING MATERIALS

Dimensional responses of painting materials to temperature fluctuations often are ignored because the effects of relative humidity [RH] are greater. But temperature should be considered in transit situations. Most materials expand and contract in response to temperature variations, and linear thermal expansion coefficients have been derived experimentally for many painting materials. A few coefficients are provided in Table 1.

Nathan Stolow studied the physical properties of hygroscopic materials and methods to control environmental conditions inside packing cases containing works of art during transit. He concluded that packing cases should be insulated to minimize temperature changes and large quantities of silica gel should be used to stabilize RH. [8] Stolow determined that temperature changes have a negligible effect on the EMC of silica gel and thus,

Material	Linear Thermal Expansion Coefficient (x 10 ⁻⁶ per °C)
White oak, <i>Quercus alba</i> , longitudinal	0.3
White oak, <i>Quercus alba</i> , radial	32
White oak, <i>Quercus alba</i> , tangential	40
Oil paint, white lead	44
Oil paint, yellow ochre	64
Oil paint, Naples yellow	52
Rabbit skin glue	29
Copper	17
Aluminum T-2024	23

Table 1. Linear thermal expansion coefficients for various painting materials. Calculation of the thermal expansion coefficient for white oak, *Quercus alba*, assumes an average specific gravity of 0.62. (Coefficients for oil paint and rabbit skin glue provided by Marion Mecklenburg, Smithsonian Institution.)

silica gel would stabilize the RH within sealed cases even with temperature fluctuations during transit. [9] It is worth noting that Stolow based this conclusion on the properties of only one type of regular density silica gel. His conclusion that temperature has a negligible effect on the EMC of silica gel is not valid, however, for all types of gel. [10]

Some scientists did not agree with Stolow's recommendation to use silica gel in cases exposed to temperature fluctuations. [11, 12] Silica gel has the capacity to adsorb and desorb large quantities of moisture as compared to most hygroscopic materials found in works of art. Differences in this response to environmental variations could cause materials to gain or lose unacceptable quantities of moisture. If temperature variations produced a significant migration of moisture between silica gel and a panel painting, it could lead to potentially damaging dimensional changes. Results obtained in this research, however, indicate that an adverse effect on panel paintings is highly unlikely with the moderate quantity of silica gel typically included in microclimate packages.

Again, it is useful to consider a hypothetical example. White oak has a linear expansion coefficient of 0.0018 per one percent change in moisture content. If a quarter-sawn one-metre-wide panel is moved from 50% to 40% RH at 20°C, its EMC would drop from 11% to 9.3%, resulting in shrinkage across the grain of approximately 3.1 mm.

Foil strain gauges of 1.25 cm length were adhered with cellulose nitrate cement on the reverse of each panel, perpendicular to the grain. Strain gauges were also adhered to aluminum alloy T-2024 and titanium silicate samples that were used as controls to ensure accurate data handling. In order to understand the environmental conditions within the packages and the consequent responses of the wood panels, over thirty experiments were conducted to evaluate the effects of several types of silica gel, various package volumes, different temperature fluctuations, and assorted exposure periods. In addition, many panel paintings inside microclimate packages were monitored with dataloggers while in transit and on loan to other institutions.

While dimensional changes that accompany temperature variations in the longitudinal direction of the wood are extremely small, the expansion coefficients of oak in the radial and tangential directions are greater. Note that the coefficients for radially and tangentially cut wood are close to the

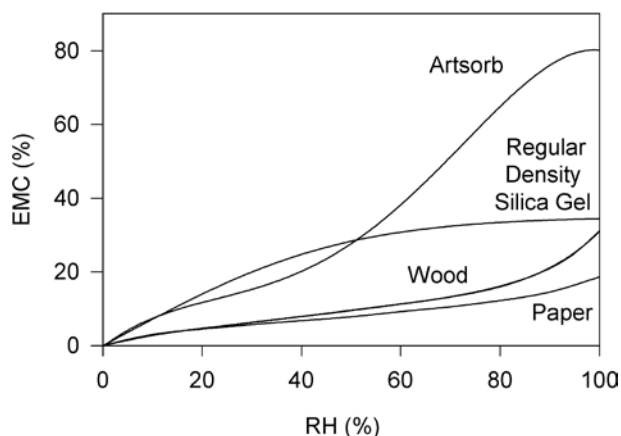

Figure 1. Moisture sorption isotherms of a few hygroscopic materials at 20°C.

coefficients of oil paint and rabbit skin glue and greater than copper and aluminum. In the longitudinal direction, wood restrains the thermal response of the glue and paint layers, increasing stress between the layers.

A good way to grasp the significance of these numbers is to consider the dimensional changes of a hypothetical painting on white oak panel during transit. A quarter-sawn one-meter-wide white oak panel in a well-sealed microclimate package will theoretically contract by 0.64 mm across the grain when the temperature drops from 20°C to 0°C. For comparison, the same shrinkage would occur with a drop in RH from 50% to 47.7%. This is a relatively small dimensional change, but one which happens very rapidly when induced by varying temperature.

EQUILIBRIUM MOISTURE CONTENT

Hygroscopic materials—wood, paper and silica gel—adsorb or desorb moisture until they attain equilibrium with the surrounding RH. At a fixed temperature, the equilibrium moisture contents (EMC) of materials as a function of RH are called isotherms (see Figure 1).

The EMC of hygroscopic materials is affected not only by RH but also by temperature and pressure. It is generally accepted that the pressure effects on the moisture content of materials sealed within microclimate packages are so negligible as to be ignored, even in the case of air shipments. Temperature effects, however, can be significant and should not be overlooked. At a constant ambient RH, increasing the temperature drives off moisture but water vapour is adsorbed when the temperature decreases. In a stable RH environment, wood will have a higher EMC at 15°C than at 25°C. A panel painting displayed in a gallery maintained at 25°C and 50% RH will have

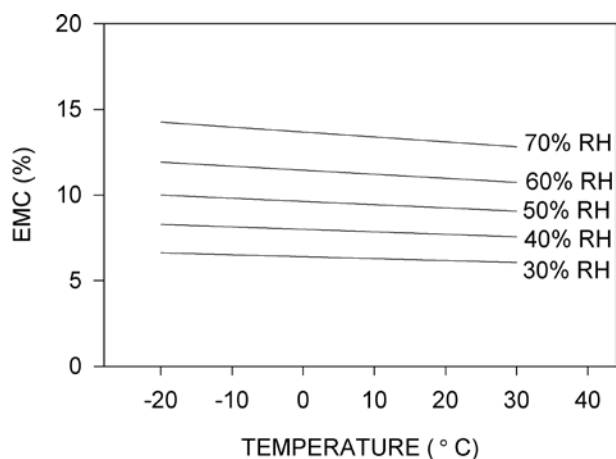

Figure 2. Relationship between temperature and the equilibrium moisture content of wood at several relative humidities.

an EMC of approximately 9.14%. If the temperature were to drop to 15°C while the humidity remained at 50% RH, the moisture content of the wood would gradually increase to 9.34%. The relationship between temperature and the EMC of wood at fixed RH levels is illustrated in Figure 2. [4]

The circumstances in a microclimate package are quite different, because the package's small air volume offers little moisture for adsorption. [5,6,7] In moving from 25°C to 15°C, equilibrium is re-established at approximately 48.5% RH, assuming a high ratio of wood volume to air space. A tiny quantity of moisture is actually adsorbed by the cooling wood in reaching equilibrium at the lower RH level, having virtually no effect on the EMC of the wood unless another source of moisture is available. To state this another way, a tightly wrapped piece of wood exchanges moisture with the surrounding air until an equilibrium RH is attained that is appropriate for the moisture content of the wood and the temperature. When the temperature changes, the process is repeated and a new equilibrium RH will be established within the wrapped air space.

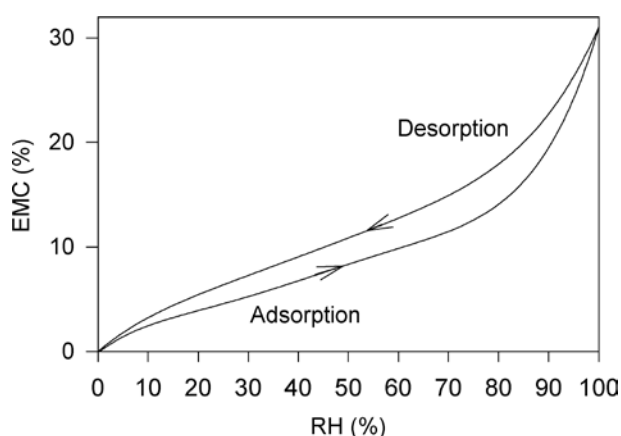

Figure 3. Moisture adsorption and desorption isotherms of wood at 20°C.

HYSTERESIS

The EMC of hygroscopic materials is not only dependent on temperature and RH but on whether equilibrium is approached from a drier or a damper environment, a phenomenon called hysteresis. A hygroscopic material moved from a dry to a damp environment will arrive at a lower EMC than one moved from a damp environment to a dry one. Similarly, materials adsorbing moisture as the temperature declines will not return to precisely the same EMC when the temperature rises. The typical hysteresis behaviour of wood is shown in Figure 3. The lower adsorption line represents the results of placing a dry piece of wood in a progressively damper environment while the upper desorption curve corresponds to the opposite situation, placing a saturated piece of wood in a progressively drier environment.

The two curves in Figure 3 define a region of the graph known as the hysteresis loop. The curves serve as the boundary lines for an infinite number of EMC points that can result from moving wood between different RH environments at constant temperature. The hysteresis loop is much smaller when wood is moved within lesser RH ranges, as seen in Figure 4 when wood oscillates between 30% and 70% RH. Silica gels exhibit pronounced hysteresis between 30% and 70% RH. Given that temperature changes will have an effect on the sorption properties of these materials as well, the exact point at which the moisture content of a wooden panel in a microclimate package comes to rest during transit is scarcely predictable. While it is important to recognize that hysteresis affects the EMC of wood exposed to changing environments, it seems unlikely that it plays a significant role in the behaviour of panel paintings enclosed in microclimate packages.

DIMENSIONAL CHANGES DUE TO MOISTURE

Dimensional changes in wood caused by variations in moisture content are anisotropic, that is, of different magnitude in the longitudinal, radial, and tangential directions. As with temperature variations, dimensional responses to moisture variations in the longitudinal direction are very small. Within moisture content limits of 6% to 14%, wood's linear expansion coefficient per one percent change in moisture content varies from 0.002 to 0.0045 (Δ length/length) in the tangential direction and from 0.001 to 0.003 in the radial direction.

All materials in traditional panel paintings are affected by fluctuations in temperature and relative

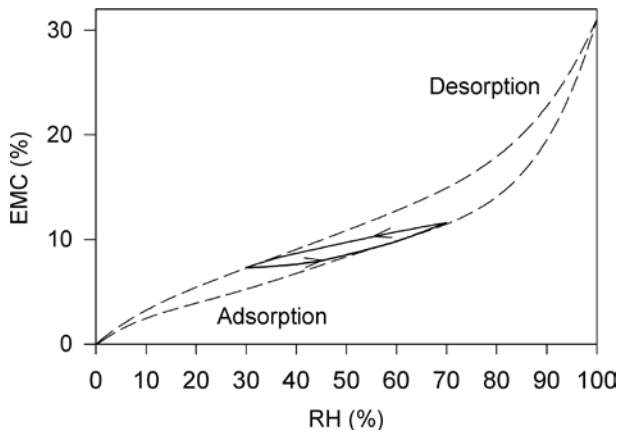

Figure 4. Moisture sorption hysteresis loop for wood between 30% and 70% RH at 20°C.

humidity. Wood's response, as already noted, is anisotropic while paint, ground, and glue size behave isotropically; they swell and shrink equally in all directions. Wood's swelling in the radial and tangential directions, as a result of relative humidity changes, is greater than that of glue size, gesso, or paint. It is significant enough that cracks in the various painting layers can develop parallel to the grain because of stress imposed on them by excessive movement of the wood. In the longitudinal direction, there is very little expansion or contraction of wood due to relative humidity changes. Since the glue size, gesso, and paint respond in all directions, the dimensional movement of these materials is restrained by the longitudinal wood when the relative humidity changes. The stress resulting from this restraint can cause formation of cracks perpendicular to the wood grain during desiccation. [13]

EXPERIMENTAL RESULTS AND DISCUSSION

One means to a better understanding of the behaviour of panel paintings within microclimate packages is to measure dimensional changes in wood panels using foil strain gauges. These small devices exhibit predictable changes in electrical resistance when stretched or compressed. Experience has shown that strain gauges work well for measuring the overall dimensional activity of quarter-sawn wood, provided the grain is reasonably uniform. They work less well with samples cut from wood sawn in other planes, and on wood with knots, cracks, or irregularities in the grain.

Experiments were performed on three quarter-sawn oak panels. The reverse of the panels had no coatings, battens, or cradles, which would alter the panel's behaviour. The first was a North American oil painting on white oak panel (c. 1900) measuring 0.25

x 0.20 x 0.014 m thick. The second was a watercolour on paper adhered to an oak panel (unknown species) estimated to be at least two hundred years old and measuring 0.48 x 0.27 m x 0.01 m thick. The third was a panel—its obverse coated with a traditional calcium carbonate gesso plus two layers of Acryloid B-72—made ten years ago from white oak flooring removed during renovation at the National Gallery of Art. It measures 0.61 x 0.40 x 0.006 m thick. In all instances, the panels were mounted inside the microclimate packages with two small polyethylene foam pads. This is significantly less support than normally used in microclimate packages, but the intention was to ensure that the mounts did not restrict the movement of the wood. Generally, the experiments were conducted with the panels positioned with the grain direction vertical, although tests showed that orientation had no effect on the results.

MICROCLIMATE PACKAGES WITHOUT SILICA GEL

Several experiments were conducted to evaluate the effects of environmental fluctuations on the dimensional responses of oak panels in microclimate packages without added buffering materials. Three packages with interior dimensions of 0.262 x 0.207 x 0.016 m; 0.417 x 0.281 x 0.032 m; and 0.619 x 0.41 x 0.036 m were acclimatised to 20°C and 50% RH for several days before dropping the temperature to 0°C.

The temperature and RH responses within the three packages were very similar, and are thus represented by single curves in Figure 5. The interior temperature dropped at virtually the same rate as the environmental chamber. The relative humidity initially increased slightly and then dropped until equilibrium was established at a lower RH. With rapid temperature changes, several factors might contribute to the observed initial rise in RH: transient temperature and RH gradients that would develop within the packages; the air would cool more quickly than the panel, possibly allowing the RH to increase before the wood began to adsorb moisture; and/or the rapidly-cooling metal housing of the RH sensor might have caused an anomalous response in the early stages of the experiments.

Figure 6 is a graph of the percent length change of the three oak panels inside their microclimate packages. For comparison, curves for the temperature-induced dimensional changes of the aluminum alloy T-2024 and the theoretical response of radially-cut white oak are provided. Moisture adsorption is not a determining factor because the only source of water is in the surrounding air. After a tiny quantity of

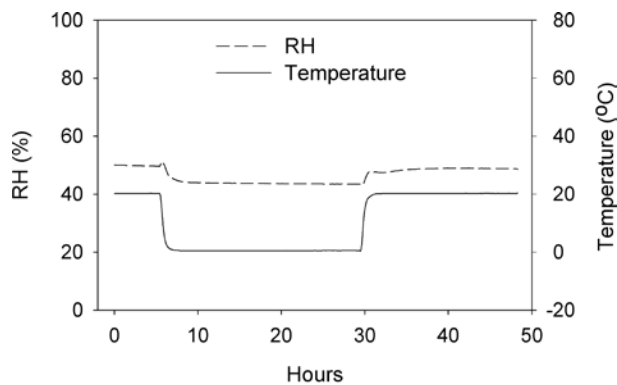

Figure 5. Temperature and RH inside a microclimate package containing an oak panel but without silica gel.

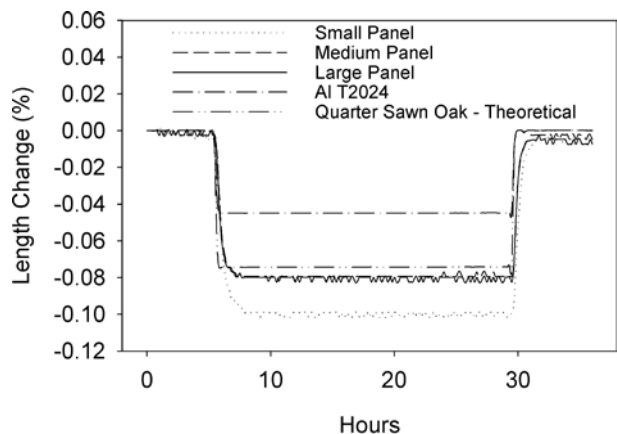

Figure 6. Percent length change ($\Delta L/L$) of oak panels inside microclimate packages (without silica gel) during temperature fluctuations. For comparison, curves are provided for aluminum alloy, T-2024 and for the theoretical dimensional change of quarter-sawn oak.

water from the air is absorbed, equilibrium is re-established at a slightly lower RH. As evident in the curves, shrinkage of the wood occurred quickly and remained constant until the temperature was raised. Similar experiments were conducted to evaluate the impact of a 20°C temperature rise and a 40°C temperature drop, yielding proportional results.

MICROCLIMATE PACKAGES WITH SILICA GEL

Multiple experiments were designed to evaluate the impact of adding silica gel to the packages. Different types and diverse quantities of gel were placed inside microclimate packages and exposed to a variety of test parameters. To illustrate, two experimental runs that included Artsorb beads have been selected. Artsorb beads were enclosed in a panel made of a polystyrene lighting diffuser covered with polyester screening. The silica gel used in the three panels weighed 187 g, 504 g, and 980 g when conditioned to 50% RH.

The experimental procedure was identical to the one described earlier, except the depth of the microclimate packages was increased to accommodate the silica

gel panels. Interior dimensions of the packages were 0.262 x 0.207 x 0.022 m, 0.417 x 0.281 x 0.038 m, and 0.619 x 0.41 x 0.042 m. Results for a drop from 20°C to 0°C can be seen in Figures 7 and 8. The temperature change inside the packages was identical to the previous example, but the spike in relative humidity was slightly greater.

Various silica gels were evaluated, yielding similar results. Anomalies did appear, not in the pattern of behaviour, but in the degree of the temporary humidity change accompanying a rapid rise or fall in temperature.

Once again, the wood panels shrank in response to the dropping temperature. The degree of initial shrinkage was slightly less than observed in the packages without silica gel but it did not remain constant. The wood gradually expanded during the 24 hour exposure to 0°C, recovering 10% of the initial shrinkage caused by temperature. That is comparable to a 0.25% change in RH. Other experiments demonstrated that the results varied with package volume, type of silica gel, quantity of gel, degree of temperature change,

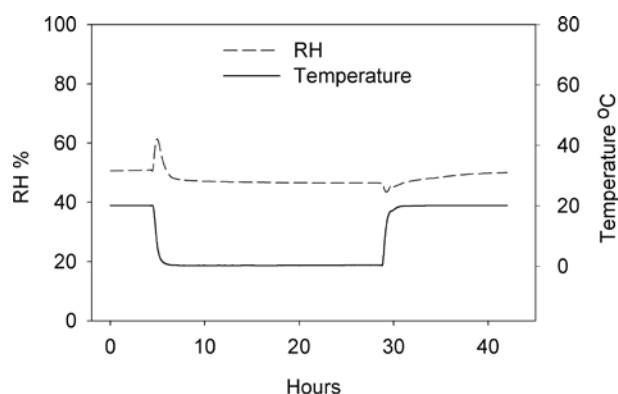

Figure 7. Temperature and relative humidity conditions within a microclimate package containing an oak panel and Artsorb.

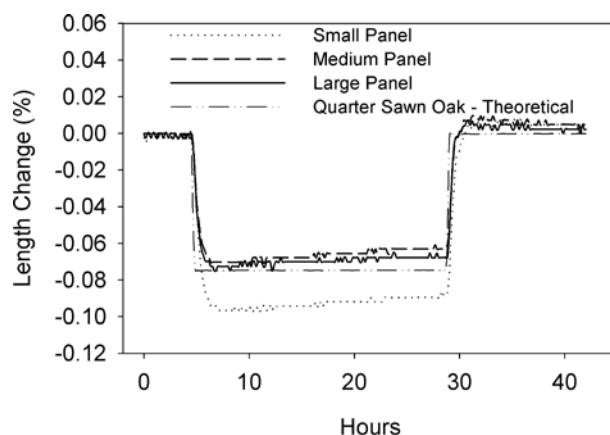

Figure 8. Percent length change ($\Delta L/L$) of oak panels inside microclimate packages (with Artsorb) during temperature fluctuations. For comparison, curves are provided for the theoretical dimensional change of quarter-sawn oak.

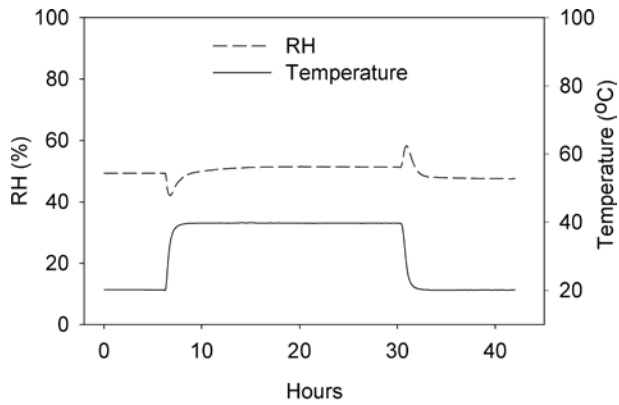

Figure 9. Temperature and relative humidity conditions within a microclimate package containing an oak panel and Artsorb.

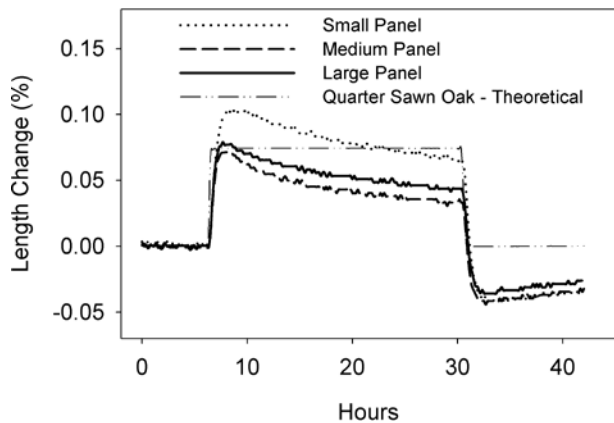

Figure 10. Percent length change ($\Delta L/L$) of oak panels inside microclimate packages (with Artsorb) during temperature fluctuations. For comparison, curves are provided for the theoretical dimensional change of quarter-sawn oak.

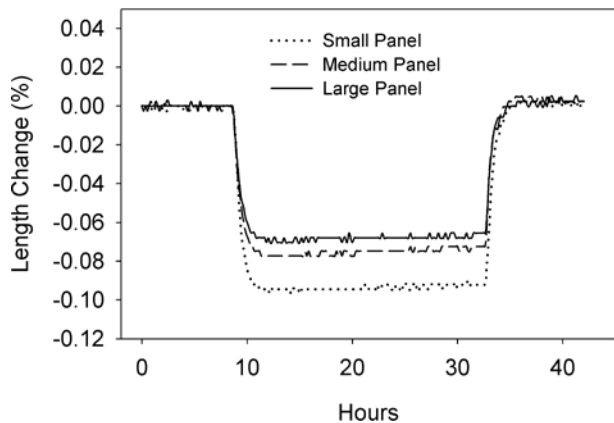

Figure 11. Percent change in length ($\Delta L/L \times 100$) of oak panels inside microclimate packages (with Rhapsid Gel) during 20°C variations.

and exposure period. However, the expansion due to moisture adsorption was always considerably smaller than shrinkage caused by the drop in temperature.

Response rates tend to be faster at higher temperatures, clearly visible in Figures 9 and 10. The pattern is a simple reverse of the cooling cycle with changes occurring more quickly.

Various sheet materials consisting of silica gel embedded in paper or synthetic fibres were tested

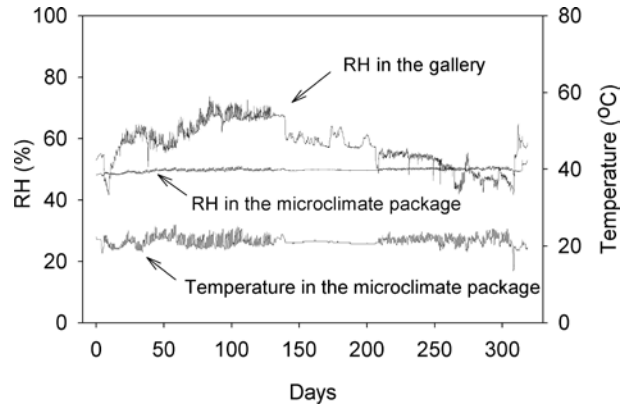

Figure 12. Environmental conditions inside and outside a microclimate package for an Italian renaissance panel painting (with Artsorb) while on loan to two museums.

with similar results. Figure 11 provides curves for the dimensional response of three microclimate packages containing a sheet of Rhapsid Gel. Per unit weight, Rhapsid Gel has buffering properties similar to Artsorb, but a single sheet contains a much smaller quantity of gel. The pattern of shrinkage was similar. However, less dimensional recovery was observed.

ENVIRONMENTAL CONDITIONS IN MICROCLIMATE PACKAGES FOR PAINTINGS ON LOAN

Many paintings loaned by the National Gallery of Art during the last twenty years have travelled in microclimate packages. In some instances, environmental conditions—both inside and outside these packages—were monitored with dataloggers. Figure 12 provides data pertaining to the loan of an Italian renaissance painting on wood exhibited at two venues. Conditions in the galleries were less than ideal, but the painting's environment within the microclimate package remained nearly stable. Small daily fluctuations, reflected in Figure 12, are almost certainly due to temperature changes caused by gallery lighting.

CONCLUSIONS

Temperature variations cause rapid dimensional changes in painting materials, including wood panels. The expansion and contraction of wood resulting from temperature variations is small, as compared to the effects of RH change within normal everyday extremes. Indeed, a 20°C temperature variation is equivalent to only an approximate 2.3% RH change. Panel paintings displayed on museum walls are regularly exposed to larger fluctuations in relative humidity without damage.

This research confirms that microclimate packages are beneficial for panel paintings being loaned to institutions

with less-than-ideal environments. Similarly, we can presume that microclimate packages work equally well for paintings on fabric supports. Well-constructed microclimate packages containing minimal air will maintain a stable relative humidity without adding silica gel, provided there is little leakage. The addition of a moderate quantity of conditioned silica gel will improve the performance of microclimate packages having a significant leakage rate. While there may be situations where temperature-induced differences in adsorption could adversely affect some materials, it is unlikely that this phenomenon poses a serious risk to the stability of panel paintings.

SUPPLIERS

ARTSORB:

Fuji Silysia Chemical, S. A.,
2-1846 Kozoji-cho, Kasugai-shi, Aichi-ken,
JAPAN 487-0013.

RHAPID GEL:

Art Preservation Services, 315 East 89th Street,
New York, NY 10128, USA.

SR-4® STRAIN GAGES:

Vishay BLH, Vishay Micro-Measurements,
PO Box 27777, Raleigh, NC 27611, USA.

METROSONICS MODEL 721 DATALOGGER:

Metrosonics, Inc., 1060 Corporate Center Drive,
Oconomowoc, WI 53066, USA
(no longer available).

TEMPERATURE/RELATIVE HUMIDITY TRANSMITTERS (MODEL 850):

General Eastern Inc., GE Sensing, 1100
Technology Park Dr., Billerica, MA 01821, USA.

AUTHOR

Mervin Richard
The National Gallery of Art, Washington D.C.
Mailing address:
2000B South Club Drive
Landover, MD 20785, USA
m-richard@nga.gov

ENDNOTES

- 1 Wadum, J., 'Microclimate Boxes for Panel Paintings', in *The Structural Conservation of Panel Paintings, Proceedings of a Symposium*

at the J. Paul Getty Museum, April 1995, ed. K. Dardes and A. Rothe, The Getty Conservation Institute: Los Angeles (1995) 497-524.

- 2 The National Gallery of Art has used flexible laminated moisture barrier films, such as Marvel-seal, for microclimate packages since 1992.
- 3 Richard, M., 'Control of Temperature and Relative Humidity in Packing Cases', in *Art in Transit: Studies in the Transport of Paintings*, ed. M. F. Mecklenburg, National Gallery of Art: Washington (1991) 279-297.
- 4 *Handbook of Wood and Wood-based Materials for Engineers, Architects, and Builders*, Published for the Forest Products Laboratory, U.S. Department of Agriculture, by Hemisphere Publishing, New York (1987) 3-11.
- 5 Thomson, G., 'Relative Humidity: Variation with Temperature in a Case Containing Wood', *Studies in Conservation*, 9 (1964) 153-169.
- 6 Thomson, G., 'Stabilization of RH in Exhibition Cases: Hygrometric Half-Time', *Studies in Conservation*, 22 (1977) 85-102.
- 7 Stolow, N., *Conservation and Exhibitions*, Butterworths, London (1987) 126-130.
- 8 Stolow, N., *Controlled Environment for Works of Art in Transit*, published for the International Institute for Conservation of Historic and Artistic Works and the International Centre for the Study of the Conservation of Cultural Property by Butterworths, London (1966) 42-44.
- 9 Stolow (1966) 11.
- 10 The author currently is investigating the adsorption properties of various desiccants.
- 11 Hackney, S., 'The Dimensional Stability of Paintings in Transit', in *ICOM Committee for Conservation, 8th Triennial Meeting, Sydney, Australia, 6-11 September 1987: Preprints*, ed. K. Grimstad, The Getty Conservation Institute, Los Angeles (1987) 597-600.
- 12 Toishi, K.J. and T. Gotoh, 'A Note on the Movement of Moisture Between Components in a Sealed Package', *Studies in Conservation*, 39 (1994) 265-271.
- 13 Mecklenburg, M. F. and C. S. Tumosa, 'Mechanical Behavior of Paintings Subjected to Changes in Temperature and Relative Humidity', in *Art in Transit: Studies in the Transport of Paintings*, ed. M. F. Mecklenburg, National Gallery of Art: Washington (1991) 279-297.



This work is licensed under a Creative Commons Attribution - Noncommercial - No Derivative Works 3.0 Licence.

THE EFFECT OF AIR TIGHTNESS ON RH BUFFERING AND CONTROL

DAVID THICKETT, PHILLIP FLETCHER, ANDREW CALVER AND SARAH LAMBARTH

ABSTRACT

It has been known for over thirty years that air exchange rate is fundamental to the hygrometric performance of display cases. However, the expense of commercial testing services and the unavailability of methods had severely limited testing. The availability of relatively inexpensive equipment and the use of simplified methods has resulted in at least a fifty fold increase in the number of air exchange rate measurements undertaken in the UK. Coupled with developments in measuring technologies for relative humidity, which has allowed more widespread and more accurate monitoring, a corpus of data now exists to assess the effect of different air exchange rates on RH buffering and control within display cases and storage enclosures. These results demonstrate that in most instances where attempts to control the hygrometric performance of enclosures has failed, air (or moisture) exchange is the key variable. The potential major drawback of tightly sealing showcases, besides cost and time, is the concentration of off-gassed products from objects, dressing or construction materials. The carboxylic acids are by far the most widely reported culprits of adverse effects on objects inside showcases and storage enclosures. Diffusion tube based measurements are ideal to determine carboxylic acid concentrations inside such enclosures and a body of such data has now been acquired. Methanoic acid emissions from paint have been shown to follow existing models. Ethanoic acid concentrations from MDF were found to increase dramatically at air exchange rates below 0.5.

INTRODUCTION

Besides providing security for their contents, the most common conservation use for showcases is to protect against relative humidity fluctuations or to allow the display of artefacts in environments that are known to be aggressive. It has been known for over thirty years that air exchange rate, AER is fundamental to showcase performance in this area [1,2,3,4]. However, the expense of commercial testing and the unavailability of methods has severely limited testing. The development of affordable methods has allowed air exchange rates to be measured in a large number of showcases [5]. This, coupled with

developments in measuring technologies for relative humidity, which have allowed more widespread and more accurate monitoring, has generated a corpus of data for assessing the effect of different air exchange rates on RH buffering and control within showcases and enclosures. Many institutions are using air exchange rate in the specification criteria for new showcases. Better knowledge of its effects can lead to better targeted, cheaper specifications.

The existing models for RH buffering and control capacity have been tested and their predictions compared to monitored data. A number of applications for calculating the performance of showcases and requirements for conditioning have been developed.

The major drawback of tightly sealing showcases, besides cost and time is the concentration of off-gassed products from showcase or construction materials. The carboxylic acids are either way the most widely reported culprits in adverse effects on objects inside showcases, storage furniture and enclosures. Diffusion tubes are ideal for determining carboxylic acid concentrations inside an enclosure and a body of such data has now been acquired. The effect of reducing air exchange rate has been assessed from such measurements combined with information about the showcase materials.

METHODS

Air exchange rate has been measured using carbon dioxide tracer gas decay following the broad method discussed in Calver et al [5]. All measurements were made with a Vaisala GMP70 data-loggers and probes. The probe was placed centrally on the base of the case and 5000 ppm of carbon dioxide injected. An initial measurement of the carbon dioxide concentration in the case before injection was made and subtracted from all subsequent readings. The air exchange rate was calculated, averaging over 72, 96 or 120 hour periods to account for diurnal effects.

Temperature and RH measurements were made with Meaco or Hanwell radiotelemetry systems, with either Rotronic Hygrostop or Vaisala Humicap probes, Hanwell Humbug dataloggers with Humicap probes, or Smartreader SR002 dataloggers. All

sensors were calibrated annually with a three point RH calibration traceable to UK National Physics Laboratory standards via the UK National Accreditation Measurement Service. In all instances temperature and RH were measured in the room space as well as the enclosure.

Where the amount of buffer could be accurately measured, ie large amounts of silica gel in enclosures with relatively little other reactive hygroscopic material, the hygrometric half life was calculated using the formula developed by Thomson [2]. The interior RH was then modelled from the room RH by simple iteration. Since there is a lag in internal RH, using the initial RH as the starting point for the model means the results are influenced by earlier RH. Better experimental fits were obtained by allowing the initial RH to vary in 1% RH intervals, 5% above and below the initial measured internal RH. The modelled RHs were compared by eye and the 'best' initial RH selected. Thomson's model assumes isothermal conditions between the case and the room and instant equilibrium of the whole buffer mass with the immediately adjacent air. Modelling was also undertaken based on the formula developed by Tetrault and Weintraub, which accounts for non isothermal conditions [6].

For cases where the amount of buffer could not be accurately measured (constructed from wood or wood based materials), modelling was applied by varying the hygrometric half life. The best half life model was determined as that with the minimum root mean square deviation between the model and the measured RH inside the enclosure. Knowing the air exchange rate of the case, the mass of buffer per unit volume was then calculated from Thomson's equation.

Carboxylic acid concentrations inside showcases were measured using diffusion tubes exposed for twenty eight days and analysis by ion chromatography [7]. Measurements were made every three months to account for the large seasonal variation in carboxylic acid concentrations in showcases containing wood products in naturally conditioned buildings. This is because large seasonal variations in temperature and RH dramatically influence carboxylic acid emissions from wood products and paints and the air exchange rates of showcases.

Since the major hygroscopic materials present in showcases exhibit hysteresis over part of the RH range found in buildings, their performance differs when the enclosure is drier or wetter than the room and when they are working at an RH below the

hysteresis region or in it [8]. Hysteresis can have a dramatic effect on the buffering capacity of silica gels, with the B_H value (defined in the appendix) in a limited RH interval being much less than expected from the sorption chart [8].

SILICA GEL AS THE ONLY BUFFER IN THE ENCLOSURE, DRIER THAN OUTSIDE, BELOW HYSTERESIS ON THE ISOTHERM

Archaeological iron can be amongst the least stable of materials and can rapidly deteriorate at RH levels above 16%. Many institutions use polypropylene boxes with silica gel to store archaeological iron. Since reliable low RH indicators are expensive and the volume of material is large, modelling the RH and hence the replacement time of the silica gel has been undertaken. Four models were tested and over thirty boxes in four different stores monitored over a period of two years. The Thomson and Tetrault and Weintraub models were found to give excellent results, with the Thomson model being computationally easier [9]. A web based application has been developed to allow other institutions to apply the model to their collections.

In order safely to display vulnerable archaeological metals in damp environments a standard showcase design incorporating silica gel has been developed and extensively tested with twelve cases in four different locations. An air exchange rate of 0.4 day^{-1} was specified for these cases from calculation using the iteration of Thomson's equation described previously and RH and AER measurements of existing desktop showcase designs [10]. The designs were found to exceed the specification and managed to retain an RH close to 20% for over twelve months in environments of up to 90% RH. A representative case is shown in Figure 1. Both the Thomson and the Tetrault and Weintraub models gave excellent results. One would expect Thomson's model to begin to fail if there are

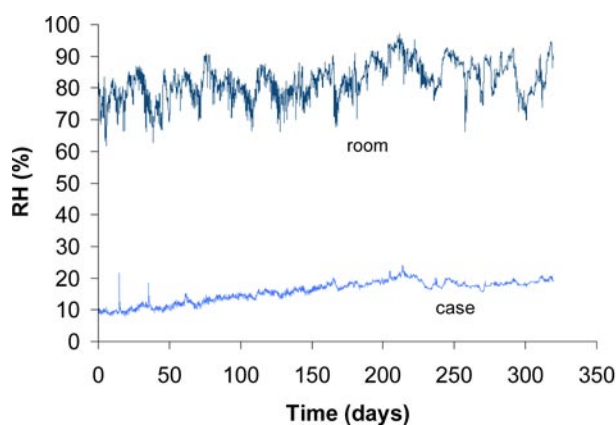

Figure 1. Conditions inside standard 'EHI' showcase at Pevensey Castle. The RH is maintained close to 20% for eleven months.

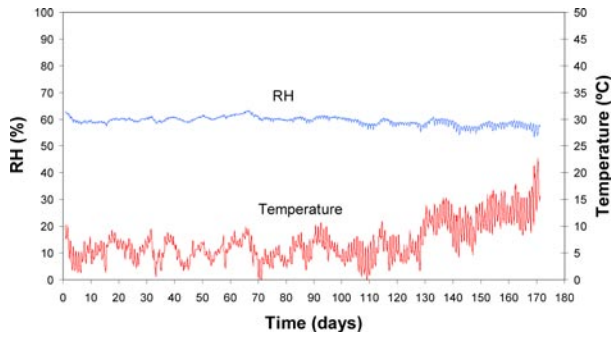

Figure 2. Lullingstone coffin case. The RH is maintained within a 10% band by use of an airtight case and ProSORB.

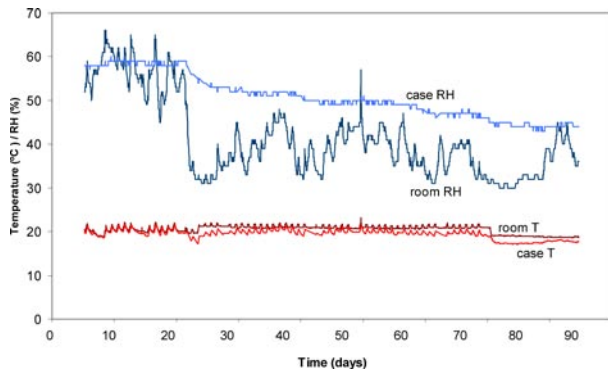

Figure 3. Down House case. The RH is maintained above 40%, during the winter/spring heating period.

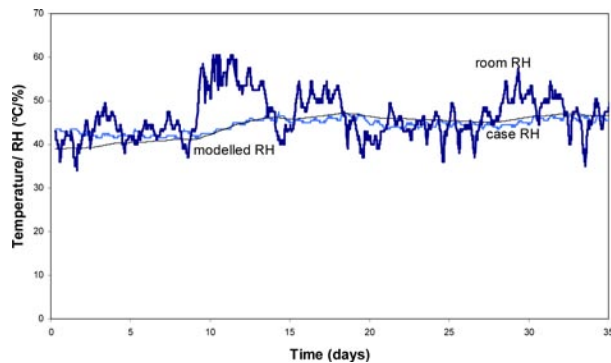

Figure 4. Apsley House cases. Modelled and measured RH. The model correctly describes the general trend, but underestimates short term RH variations.

temperature differences between the showcase and the outer space. Since these cases are not internally lit and direct sunlight illumination of the cases has been intentionally excluded, the temperature difference is negligible (less than 0.5°C).

SILICA GEL AS THE ONLY BUFFER IN AN ENCLOSURE, DRIER THAN OUTSIDE, IN HYSTERESIS REGION ON ISOTHERM

Both regular silica gel and then ProSORB have been used in a showcase containing a lead coffin and skeleton, displayed in a damp building. Initially the case fluctuated between 25 and 65% RH using normal silica gel, replaced with dry gel at six month intervals. Reducing the air exchange of the case and replacing the regular silica gel with ProSORB allowed

much better control, 50-65%, and removed the dangerous low RHs when the silica gel was changed (figure 2).

SILICA GEL AS ONLY BUFFER IN ENCLOSURE, WETTER THAN OUTSIDE IN THE HYSTERESIS REGION OF ISOTHERM.

Three showcases displaying natural history collections in a house that is thermostatically heated for human comfort were found to have dangerously low RH throughout the winter and spring. Since their performance was inadequate, they were resealed. This reduced the air exchange rates from 4.5, 4.9 and 6.2 per day to 0.7, 0.6 and 0.8 per day, improving the cases' performance to acceptable levels, retaining an RH above 40% throughout the heating period (figure 3).

SOME HYGROSCOPIC MATERIALS, AMBIENT RH

It is difficult to estimate the amount of buffer available in a showcase constructed of wood. Not only is it difficult in retrospect to calculate how much wood is in the case, but the slow penetration of water vapour into wood means that it is likely that the whole thickness of the wood is not contributing to the buffering effect. This means that even knowing how much wood is present and its sorption curve will not necessarily give an accurate measure of the buffering potential. A series of ten nineteenth century showcases used to display silver has been investigated. The empirical, numerical approach described earlier has been used. The best fit half life was determined from the minimum square root variation. As can be seen in figure 4, the Thomson model gives a good overall fit, but underestimates the short term variations in humidity, particularly the daily variations driven by temperature changes. This is not unexpected, as wood responds slowly to changes in RH, with short term changes causing rapid equilibration at the surface of the wood, but longer term changes taking several days for deeper wood to respond [11]. The amount of buffer reacting, the B value in the model, therefore depends on the time scale of the RH changes and a single hygrometric half life as predicted from this approach would be inadequate.

SILICA GEL AND HYGROSCOPIC MATERIALS, AMBIENT RH

A series of measurements over three years on nine showcases with artsorb, has shown that cases with an air exchange rate above one per day were unable to maintain a 40% to 60% RH band over a period of ten months [12]. The placing of the artsorb within the display plinths in the cases means that all the

densely displayed objects have to be removed to change it and the opening of the house means this is extremely difficult until the winter closed period.

MECHANICAL CONTROL

In order successfully to control the RH inside a showcase or enclosure, a mechanical control system needs to be able to supply or remove water vapour to the air, faster than it is entering or leaving the showcase. The ingress or egress rate can be calculated from the air exchange rate and internal and external hygrometric parameters. Depending on the closeness of control required, one may need to consider the instantaneous rates, as these can vary significantly over the diurnal cycle.

CIRCULATING SYSTEMS

A major new exhibition in the gatehouse at Kenilworth Castle required close environmental control for vulnerable loan material in a room with a known poor environment. The recent marketing of a close control, low maintenance circulated system for showcases, Miniclimate EB08 and 09, appeared an ideal solution for this application. In order to prove the technology to lenders, a unit was placed in a showcase in the foyer of the English Heritage head office. Its performance was monitored over a year and found to be suitable. To expand the data set and define the showcase specification, air exchange rate measurements were undertaken on showcases at the Post Office Museum. This institution had Miniclimate units installed three years ago (the earliest installation in the UK) and monitoring confirmed their performance. The required conditioning load was determined from a year of environmental monitoring data in the proposed exhibition space, and from loan conditions. Combined with the Post Office Museum data and foyer trials, this information was used to develop the showcase air exchange rate specification. After installation of the exhibition in April, the monitored data has been compared to the specification. The results are shown in Table 1. All of the cases except one performed as predicted. The tapestry case showed a series of short lived temperature and RH spikes around 4 pm every day over the late autumn. These coincided with infra-red illumination of the compartment containing the conditioning unit through a single white blind on one of the windows. This increased the compartment temperature, reducing the dehumidification capacity of the Peltier unit in the conditioning unit. Improving ventilation in this compartment by adding a fan drawing air into the compartment overcame this.

Case	Air Exchange Rate (day ⁻¹)	Volume (m ³)	Control range (%)	Percentage time within range
tapestry	0.11	4.5	45-55	99.47
paintings	0.59	6	45-55	100
manuscripts	0.86	0.67	50-60	100
leather	0.69	1.2	45-55	100

Table 1. Performance of Cases Controlled by Miniclimate Units

The RH failure times for the showcases, meaning the period that they will retain acceptable RH conditions after the mechanical control device has failed, was calculated for different additions of Prosorb to the showcases. Within this time, the mechanical systems would need to be repaired or replaced or the objects would need to be removed to safe storage. For the Kenilworth exhibition, the remoteness of the site, lack of specialist staff and use of a foreign made conditioning system all mean that response time is likely to be relatively long. Therefore, 8kg/m³ of Prosorb was incorporated into every showcase. In the event of a system failure this was calculated to provide a window of twenty days in which to respond, by repairing the control unit or moving the objects affected to safe storage, before the case climate would move outside the specified loan conditions.

When the loan of objects in one case finished they were replaced with low vulnerability stone artefacts. The Miniclimate unit was turned off and the performance of the case compared to the model described above. Extremely good agreement was observed, as shown in Figure 5.

DEHUMIDIFIERS

Ducted Munters dehumidifiers are used in showcases at Peveril Castle and in the Mesopotamia and Ancient Levant Galleries in the British Museum. These contain

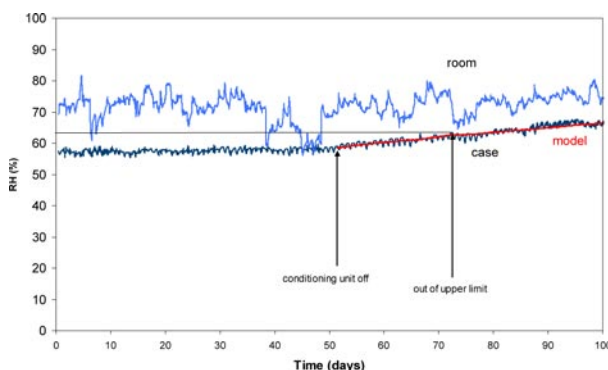

Figure 5. Modelled and measured RH inside a showcase after the conditioning unit was switched off. Note the good agreement with the modelled failure time.

Construction	Glass	Glass	Perspex
Volume (m ³)	2	2	0.5
Air Exchange Rate (day ⁻¹)	20.46	6.52	4.09
RH range (%)	Percentage of readings in RH range		
<20	0.05	3.15	28.00
21-25	0.33	12.56	44.36
26-30	8.68	59.89	22.47
31-35	60.50	24.40	4.68
36-40	29.32	0.00	0.50
40-42	1.00	0.00	0.00
42-43	0.10	0.00	0.00

Table 2. Performance of Cases Controlled with Dehumidifiers

vulnerable archaeological copper alloys showing signs of bronze disease. The conditioning systems aim to keep the RH below 42%. The air exchange rates of the cases and the annual distribution of RH values are shown in Table 2. As can be seen cases with air exchange rates of 7, and below maintain RHs below 42% while the one with a higher AER just fails.

The instantaneous dehumidification requirement for a series of showcases displaying human bones in a wet church was calculated from the specified air exchange rates of the cases, their volumes, the measured temperatures and relative humidities in the church and the desired RH of less than 65%. The results are shown as figure 6. The required dehumidification load is well below the capacity of the unit selected (minimum of 110g/m³ over the measured temperature range).

LIMITATIONS OF THIS APPROACH

The Thomson model works reasonably well provided there is no significant temperature difference between the enclosure and the room. If there are significant differences, because of internal lighting or sunlight, then that approach will break down. Modelling using the Weintraub and Tetrault equation in these conditions would require an estimate of

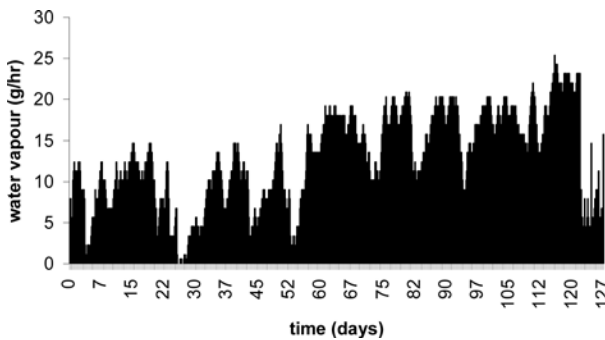

Figure 6. Modelled instantaneous dehumidification load at St Peter's Church, Barton. The required water vapour removal rate is below 30g/hr.

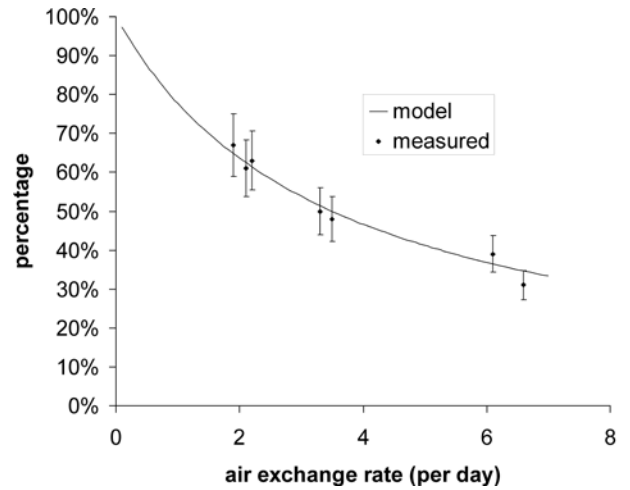

Figure 7. Methanoic acid concentrations inside painted cases at Kenwood House. Concentrations are expressed as a percentage of the equilibrium concentration expected inside a perfectly sealed enclosure. The line is the modelled concentration from Meyer and Hermanns [15].

the internal temperature, which is not a trivial exercise. The temperature differences will be strongly varying with time, due to lighting during opening hours and sunlight heating being a function of room and window geometry, orientation and time of the year. This would require intimate knowledge of crack and hole location and dimensions [13], which is unlikely to be readily available and in many instances can be extremely difficult to determine.

METHANOIC (FORMIC) ACID EMISSION FROM PAINT

Application of an unsuitable paint to the inside of a series of wooden cases caused dramatic corrosion of jewellery solder. A series of carboxylic acid measurements confirmed that emission of methanoic acid was causing the corrosion, which had been identified as a lead methanoate by x-ray diffraction. A series of refits to increase the air exchange rate was undertaken on four cases to reduce the concentration. A case with similar initial concentration was measured as a control through out this work. Methanoic acid emission from paints is likely to be a strong function of temperature and a control was needed to quantify this effect [14]. The series of concentrations and air exchange rates allowed testing of the Meyer and Hermanns model [15].

The measured methanoic acid concentrations ratioed against the equilibrium concentrations, determined from the control case concentrations and air exchange rates, are shown in figure 7. As can be seen, the concentrations fall well onto the predicted values.

A set of showcases at the British Museum constructed over the past twelve years using similar designs and materials was selected to give a range of air exchange rates. Cases without objects that could be sources of carboxylic acids were selected and the surface area of an internal source, Moistop sealed MDF base and back boards, was measured [16]. All other materials in the showcases had undergone and passed accelerated corrosion tests with lead, indicating an extremely low emission rate of carboxylic acids.

The air exchange rates, and ethanoic acid concentrations are shown in Figure 8. Summer measurements are significantly higher as both temperature and RH increase the emission rate from wood products [17]. The acid concentration increases dramatically when the AER drops below 0.5. This result has important ramifications for showcase design. However the geometry of a showcase may affect this relationship. All the showcases investigated here were approximately 2m high, 0.5 to 1m deep and 2 to 4 m wide, with 'pull and slide' doors as the front face.

CONCLUSIONS

As expected the absolute importance of air exchange rate on an enclosure's ability to buffer or have the RH controlled within it, has been confirmed. The equations developed by Thomson and Tetrault and Weintraub have been verified and shown to have significant potential to predict the internal environment of enclosures from climate data for rooms and parameters for the enclosures. The predictions are not comprehensive; empirical methods are required when the amount and type of buffering material is not known (wooden carcasses). Surprisingly, the Weintraub and Tetrault equation does not appear to give better results, even when lighting causes internal temperature gains of up to 2°C. The Thomson equation is computationally easier. The data can be used to design enclosure air exchange rate specifications which, coupled with rigorous testing and refitting as necessary, will provide 'guaranteed' internal environments. Of course, changes in room environments and other effects such as infra-red radiation through blinds will affect the internal RH.

Carboxylic acid concentrations increase as the air exchange rate decreases. The Meyer and Hermanns model appears to hold well for

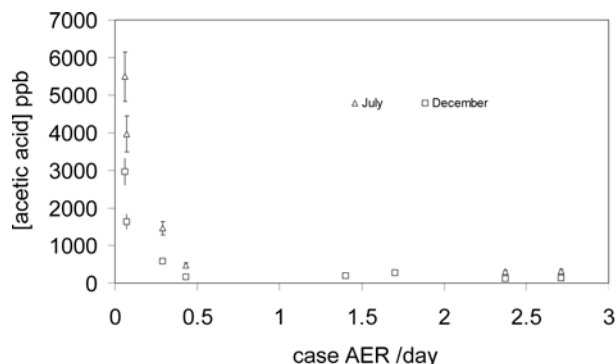

Figure 8. Ethanoic acid concentrations in a series of cases at the British Museum. Concentrations increase sharply when AER drops below 0.5 per day. Summer concentrations are higher, because higher temperature and RH increase the emission rate from medium density fibreboard.

methanoic acid emission from paint. However an extremely interesting non linear effect for ethanoic acid in showcases of a particular geometry and construction type has been observed. For this geometry the concentration increases dramatically when the air exchange rate drops below 0.5 per day. If this behaviour is general then it has very important implications for showcase air exchange rate specifications and mitigation of ethanoic acid concentration and its adverse effects on artefacts.

AUTHORS

David Thickett and Sarah Lambarth
English Heritage,
1 Waterhouse Square, 138 Holborn,
London, EC1N 2ST, UK
david.thickett@english-heritage.org.uk

Phillip Fletcher
The British Museum,
Great Russell Street,
London, WC1B 3DG, UK

Andrew Calver
Museum of London,
150 London Wall,
London EC2Y 5HN, UK

REFERENCES

- 1 Padfield, T. 1966, The control of relative humidity and air pollution in show-cases and picture frames, *Studies in Conservation* 11, 8–30.
- 2 Thomson, G. 1977, Stabilisation of RH in exhibition cases: hygrometric half time, *Studies in Conservation* 22, 85–102.

- 3 Brimblecombe, P. and B. Ramer, 1983. Museum display cases and the exchange of water vapour *Studies in Conservation* 28, 179–188.
- 4 Cassar, M. and G. Martin, 1994. The environmental performance of museum display cases. Preventive conservation: practice, theory and research. Contributions to the IIC Ottawa Congress, 1994, 171-174
- 5 Calver A., Holbrooke, A., Thickett, D. and Weintraub, S. 2005. Simple methods to measure air exchange rates and detect leaks in display and storage containers. In: I. Verger, ed. Preprints of ICOM-CC 14th Triennial Meeting Hague. London. 597–609
- 6 Tetrault J., 2003. *Airborne Pollutants in Museums, Galleries and Archives*, Canadian Conservation Institute, Ottawa, p58
- 7 Gibson, L.T., Cooksey, B.G., Littlejohn, D, and N.H. Tennent, 1997. A diffusion tube sampler for the determination of acetic acid and formic acid vapours in museum cabinets, *Analytica Chimica Acta*, 341, 11-19
- 8 Weintraub, S. 2002. Demystifying silica gel. In Object Specialty Group
- 9 Thickett D. and M. Odlyha, 2007. Assessment of dry storage microenvironments for archaeological iron, *Postprints of Archaeological Conservation*, Williamsburg, in press Postprints. 9, Washington, D.C.: American Institute for Conservation., available at http://www.apsnyc.com/pdf/silica_gel_SW_2003.pdf
- 10 Thickett D. and N. Luxford, 2007. Controlled RH cases for archaeological metals in aggressive environments, *Metals 07*, in press
- 11 Bratasz L., Jakiela, S. and R. Kozłowski. 2005. Allowable thresholds in dynamic changes of microclimate for wooden cultural objects: monitoring in situ and modeling; In Preprints of 14th Triennial Meeting of ICOM-CC, The Hague, 582-589
- 12 Thickett D., David F. and N. Luxford, 2005. Air Exchange Rate – the Dominant Parameter for Preventive Conservation? *The Conservator*, 29, 19-24
- 13 Michalski S., 1994. Leakage prediction for buildings, bags and bottles. *Studies in Conservation* 39, 169–186.
- 14 Tetrault J., 1999. *Coatings for Display and Storage in Museums*, CCI Technical Bulletin, 21, Canadian Conservation Institute, Ottawa, 58
- 15 Meyer B. and K. Hermanns, 1985. Formaldehyde release from pressed wood products, Formaldehyde: *Analytical Chemistry Toxicology*, American Chemical Society, Washington DC, 101-116.
- 16 Thickett D. 1998. Sealing MDF to Prevent Corrosive Emissions. *The Conservator* 22, 49–56.
- 17 Thickett, D. and S.M. Bradley. 1998, Effects of carboxylic acids on metals, *Preprints of Metals98*, 260-265

APPENDIX

Thomson introduced the concept of hygrometric half life, which while a simplification of reality has provided beneficial insights for many years [2].

$$t_{1/2} = \frac{4MB}{N}$$

where $t_{1/2}$ is the hygrometric half life (days)

M is the loading of absorbent in the chamber (kg/m^3)

B is the specific moisture reservoir of silica gel (kg/kg per 1%RH)

N is air exchange rate (day^{-1})

Weintraub and Tetrault developed an equation to determine the amount of silica gel required to buffer to a given RH fluctuation, which can be modified to estimate the time taken to reach a given RH [8].

$$t_{RH} = \frac{M_H FB}{C_{eq} DN}$$

where t_{RH} is time to reach a specified RH (days)

F is targeted range of RH fluctuation (%)

M_H is specific moisture reservoir corrected for hysteresis (no units)

B is loading of absorbent in chamber (kg/m^3)

C_{eq} is equilibrium concentration of water vapour (g/m^3)

D is decimal difference between external RH and chamber (no units)



This work is licensed under a Creative Commons Attribution - Noncommercial - No Derivative Works 3.0 Licence.

MUSEUM SHOWCASES: SPECIFICATION AND REALITY, COSTS AND BENEFITS

SIOBHAN WATTS, DAVID CROMBIE, SONIA JONES AND SALLY ANN YATES

ABSTRACT

This paper explores the practical application of the theory of museum showcases, including the contradictions within our specifications, how the management of the contract affects the final product, and the reality of the compromises made when you are confronted by the two main drivers of a project – programme and budget. Case studies of a range of gallery development projects at National Museums Liverpool illustrate some significant lessons learned from the procurement of showcases. The impact of case lighting and gallery ventilation systems on the measurement of air exchange rates is explored, and heat build up from lighting systems is shown to increase the air exchange rate by a factor of 4. The difficulty of ensuring that the recommended ventilation and off-gassing periods are upheld is discussed. Measurements of VOC concentrations within relatively air tight cases two years after installation showed that concentrations remain high. Communication of the associated risks and benefits to others on the project team within a formal project management structure is shown to be at least as beneficial as producing good technical specifications for the showcases.

INTRODUCTION

The cost of showcases is a major component of the budget for most gallery creation projects, and museum showcases are a highly specialised product with a comparatively limited number of suppliers. Frequently, the showcase microenvironment is the primary means of environmental control for vulnerable and valuable collections. In comparison to close control air-conditioning, showcases are a relatively cheap, energy efficient method of protecting collections [1]. There has been a significant body of published research into how to ensure that this microclimate protects the collections being displayed, and the specifications for showcases are usually rigorous in applying this knowledge. Despite this, museums too frequently end up with showcases that do not meet the specification, and do not provide the protective microclimate that is one of their primary functions.

National Museums Liverpool undertook a major review of showcase specifications and policy between 1997-1999 ahead of a complex, large scale, capital development project called Into the Future. This project ran from 1999 to 2005 and involved the procurement and installation of 150 display cases in a number of different galleries. Early in the project there was a decision not to install close control air-conditioning in most of the galleries, but to rely on high performance cases for environmental control. With such a large investment, it was important to define the showcase performance and ensure that the specifications were met. This paper discusses this process, and compares the approach to that taken in a subsequent project of smaller scale, the Reveal gallery at National Museums Liverpool's Conservation Centre.

METHODS FOR ASSESSING SHOWCASE PERFORMANCE

AIR EXCHANGE RATES

Air exchange rate measurements were carried out in several phases, with initial phases (2000 to 2005) being undertaken by BSRIA Ltd, using a nitrous oxide tracer gas decay method [2]. From 2006, measurements were undertaken by the authors using the carbon dioxide tracer gas method outlined by Calver et al. [3]

MEASUREMENT OF AIR QUALITY

Concentrations of aldehydes and VOCs were measured using passive diffusion samplers supplied and analysed by the Building Research Establishment (BRE), and organic acids were measured using passive diffusion tubes supplied and analysed either by Oxford Brookes University [4], or by Strathclyde University [5]

Polished coupons of lead, silver and copper were also placed in showcases for long term monitoring of the effect of VOCs on metal objects [6]. The coupons were visually assessed in comparison to control coupons that had been wrapped in acid-free tissue and stored in the laboratory for the same length of time.

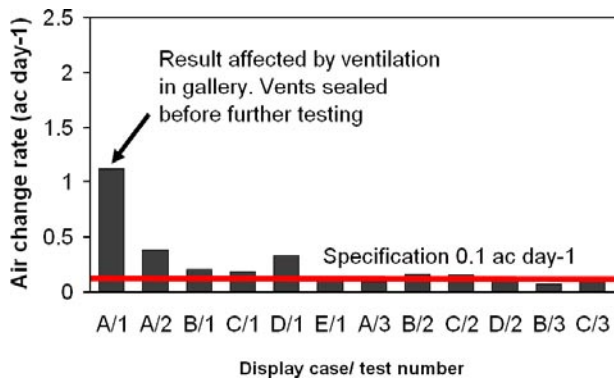

Figure 1. Air exchange rate measurements of *Into the Future* sample cases

MONITORING OF TEMPERATURE AND RELATIVE HUMIDITY

Temperature and relative humidity (RH) monitoring was carried out using either Hanwell Humbug dataloggers, or a Hanwell radio telemetric monitoring system. During air-exchange rate measurements undertaken in house, temperature, RH and light levels in the showcases were recorded using an Elsec 764 Environmental Monitor.

AIR EXCHANGE RATES: HOW TO TEST THEM AND WHAT THEY MEAN.

There has been much emphasis on quantifying and testing the air exchange rate of a display case [1, 3, 7], and an airtight case is still seen as being an important factor in providing the best microclimate for vulnerable collections on display. But what do we mean by air-tight? 0.1 air changes per day (ac day-1) has been proposed as a standard that museum cases can theoretically be built to meet [1, 8], but what are the costs of meeting this specification, and what are the benefits? Once an air-tightness specification is agreed, what is the best approach for ensuring the case meet this?

DIFFERENT APPROACHES TO MEASURING AIR EXCHANGE RATES

Two approaches to testing air tightness have been carried out by museums in recent years. The first approach involves contracting a specialist company, such as BSRIA Ltd (formerly the Building Services Research and Information Association) to measure the air exchange rates[1]). The costs of this are at least £500 per case tested, so that for large gallery projects, only a small fraction of the cases is usually tested. One of the recommendations from large gallery projects at other museums has been that in order to ensure that air exchange rate specifications are met, all cases should be tested [9].

The second approach follows the development of a method for measurement of air exchange rates that can easily be employed by conservators or conservation scientists in-house. This has led to the potential to test many more of the installed cases [3]. Other factors then need to be considered – staff resources to carry out the testing, and the impact on the installation programme if every showcase is tested individually (and potentially may need adjusting before exhibits can be installed).

National Museums Liverpool employed the first of these approaches for testing showcases for the *Into the Future* project. In this instance, we were able to stipulate that the showcase contractor should produce sample cases or prototypes for testing. Five sample cases selected to represent the different case types were produced, and air exchange rate measurements were carried out by BSRIA Ltd, using a tracer gas decay method [2]. The results are illustrated in Figure 1. Initial air exchange rate measurements indicated that none of the cases were within the specification of 0.1 ac day-1. An air exchange rate of 1.3 ac day-1 was recorded for one of the cases (case A test 1) located immediately below the inlet to the gallery ventilation system, which may have affected the result. After the vents were sealed and the system shut down, the case was re-tested and found to have an air-exchange rate of 0.38 ac day-1 (case A test 2). Additional silicone sealant was applied by the manufacturer to selected areas of the cases, and they recalled one desktop case (case D) to their factory for re-alignment. The cases were then re-tested, and the air-exchange rates had improved so that all the cases finally had an air-exchange rate of less than 0.12 ac day-1 (test 2 cases C and D and test 3 cases A, and B in Figure 1). When the final cases were installed in the galleries, the initial investment in sample cases and testing programme proved its worth. The installed cases selected for testing were different to the initial sample cases, but were again chosen to represent the main case types.

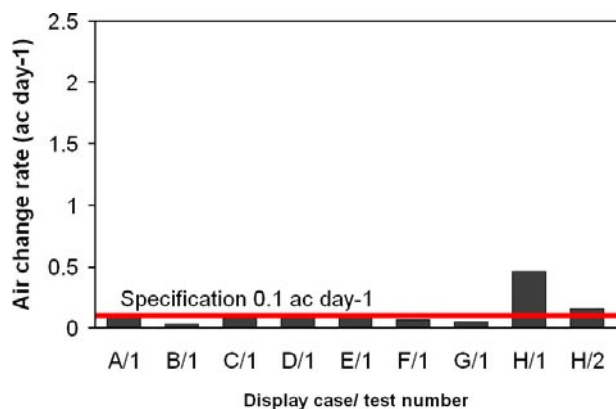

Figure 2. Air exchange rate measurements of *Into the Future* final cases

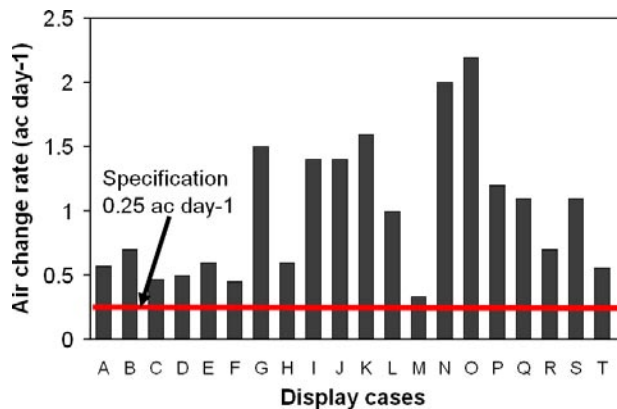

Figure 3. Air exchange rate measurements of Reveal cases

All the cases had an air exchange rate of less than 0.12 ac day-1 the first time they were tested (Figure 2), with the exception of the case H, a desktop case. The initial air exchange rate measured for AM/08 was 0.46 ac day-1, and it was noted that there was some play in the locks of this case and that the glass lid was not closing onto the sealant. The case was realigned by the case installation team, and the air exchange rate improved to 0.16 ac day-1.

In comparison, a more recent gallery project (Reveal: the Hidden Story of Objects) of much smaller scale employed the in-house testing method developed by Calver et al. [3], with the aim of testing every showcase as it was installed. However, testing was left until the final weeks of the exhibition installation. 20 out of the 25 display cases were tested, either before installation of the objects or afterwards. Even though the air-tightness specification had been relaxed to 0.25 ac day-1, none of these cases were within the specification, and there was insufficient time to rectify the problem and significantly improve the air-tightness before objects were installed. Figure 3 illustrates the results from the air exchange rate measurements for these cases, with air exchange rates between 0.3 and

2.2 ac day-1. The results are from measurements made over 12 hours overnight, and represent the performance of the cases without taking account of the impact of the case lighting systems, which is discussed in more detail below.

0.1 AIR CHANGES PER DAY – IS IT WORTH IT?

We changed the case specification for the Reveal project from 0.1 to 0.25 ac day-1, since it was felt that the additional cost incurred in the construction of cases of 0.1 ac day-1 was not warranted by the benefits. Some case manufacturers currently quote a premium of 5-10% of the case cost for manufacturing a display case to a specification of 0.1 ac day-1, with the increase relating entirely to additional installation costs. The care taken over the alignment of the case, and the sealing of joints is a major factor in producing an airtight case.

The assessment of the sample cases for the Into the Future project included monitoring temperature and relative humidity in the empty showcases, and in the gallery environment. The aim of the monitoring was to investigate the response of cases with different air tightness to variations in ambient conditions. Figures 4a and 4b illustrates that there was no significant difference between cases measured at 0.12 and 0.38 ac day-1 to short term fluctuations in the ambient environment. Figure 5 shows the response of the same two cases to fluctuations in the gallery over a longer period. As expected, the better sealed case was more effective at buffering longer term RH changes (Figure 5a) and the relative humidity within this case remained lower than in the leakier case (Figure 5b). The temperature in the cases is consistently lower than in the gallery, because the datalogger in the gallery was placed at a higher level than those in cases, so the results reflect the temperature gradient within the room.

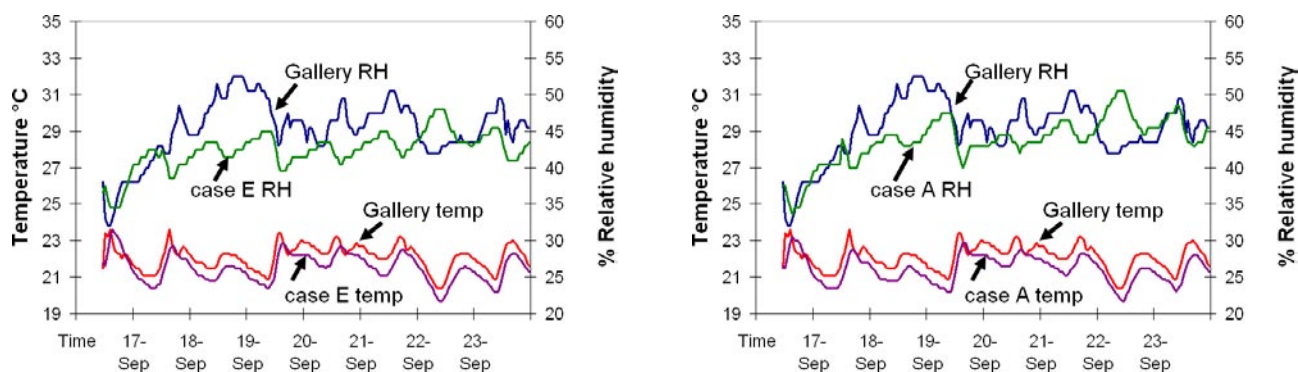

Figure 4. The response of cases with different air leakage rates to short term fluctuations in ambient gallery relative humidity and temperature.

a. RH and temperature in a display case measured at 0.12 ac day⁻¹ over 1 week.

b. RH and temperature in a display case measure at 0.38 ac day⁻¹ over 1 week

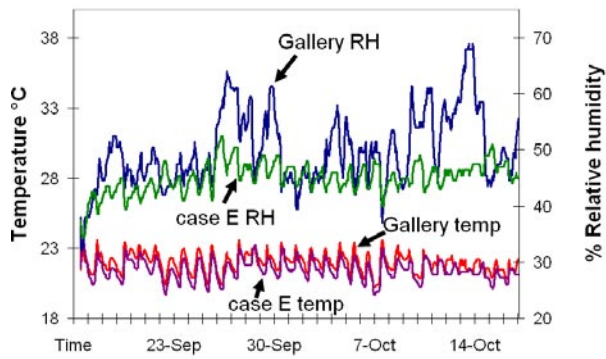
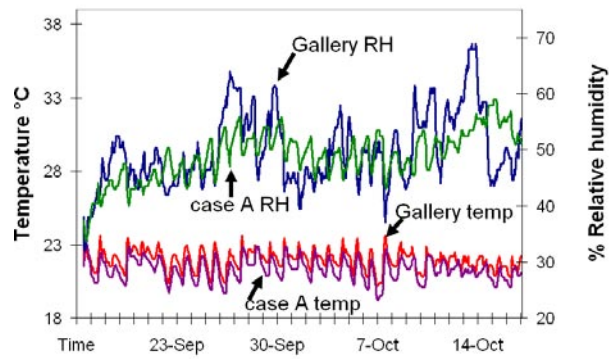

Figure 5. The response of cases with different air leakage rates to longer term fluctuations in ambient gallery relative humidity and temperature.

a. RH and temperature in a display case measured at 0.12 ac day⁻¹ over 1 month.



b. RH and temperature in a display case measured at 0.38 ac day⁻¹ over 1 month

When specifying the air-tightness of a case, consideration needs to be given to the ambient environment – a very air-tight case may not be suitable for a gallery with diurnal fluctuations in temperature but little seasonal drift. The specification of 0.1 ac day⁻¹ for the Into the Future galleries was informed by dynamic thermal modelling of the galleries in which the showcases were to be installed, and as a consequence adjustments were made to the control strategies for the comfort cooling systems to reduce the short term temperature fluctuations in the galleries.

IMPACT OF LIGHTING SYSTEMS ON CASE PERFORMANCE

Our showcase specifications originally stated that the case lighting systems should not result in any heat gain within the case, and requested that drivers for fibre optic projectors should be placed remotely, or above the case rather than below the case volume. Experience has shown us that this is unrealistic, and the case lighting frequently has a significant effect on the case microclimate. The impact on air exchange rate has been noted by others [7], and is clearly

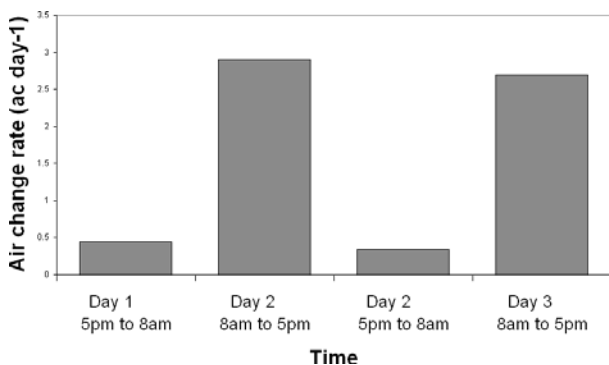

Figure 6. Diurnal changes in the air exchange rate of Case M in the Reveal Gallery.

illustrated by this example of the diurnal effect of the case lighting system (Figure 6). The air exchange rate varies from 0.4 ac day⁻¹ at night when the lights are off, and nearly 3 ac day⁻¹ during the day. This pattern of extreme and sudden variation between the air exchange rates measured in the day and night was observed for a large proportion of the cases in the Reveal Gallery. More detailed tests were carried out on one case (Reveal case S), to investigate whether this variation resulted exclusively from the case lighting system. This case (Figure 7) has a lighting system of both fluorescent lighting and fibre optics, with the projector for the fibre optics located in a light box above the main volume of the case. The external dimensions of the case are 1350 x 1550 x 340 mm, with a hinged door on one side that opens the full width and height of the case enclosure.

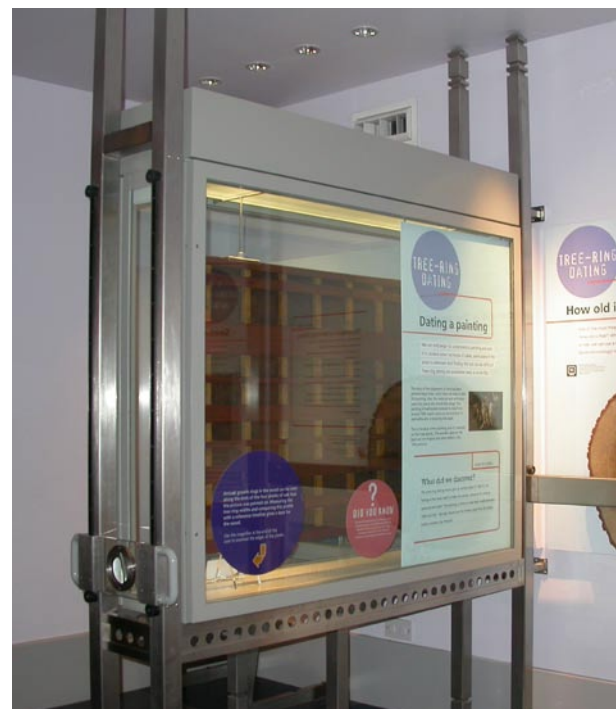

Figure 7. Case S in the Reveal Gallery.

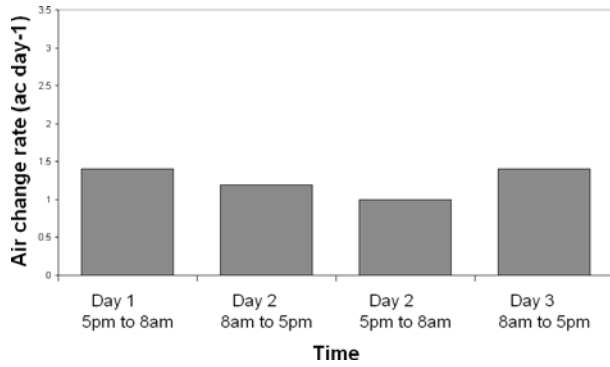

Figure 8. Air exchange rate measured in Reveal case S over a 48 hour period, with the case lighting off and gallery ventilation on for the duration of the testing period.

As well as the impact of case lighting systems, we also investigated the effect of the gallery ventilation system, given the large reduction in the air exchange rate noted above for one of the Into the Future test cases following the sealing of air vents in the gallery where the case was tested. Case S is located directly below two of the main air inlets for the gallery ventilation system. Table 1 summarises the results of the air exchange rate measurements under differing conditions, with case lights on during the day, or switched off completely for the duration of the test, and with the gallery ventilation on for the duration of the measurements or switched off. The results demonstrate clearly that the case lighting system is responsible for the variation in air exchange rate of the case. When the case lighting was switched off, the air exchange rate of the case remained constant (Figure 8). When the gallery ventilation was switched off but the case lights turned on as usual during the day, the same diurnal effect on the air exchange rate was observed. There was a slight reduction in the air exchange rate when the ventilation was off, but this is within the error of 20% for the measurement method estimated by Thickett et al. [7], so would need further measurements to determine whether this apparent contribution is significant.

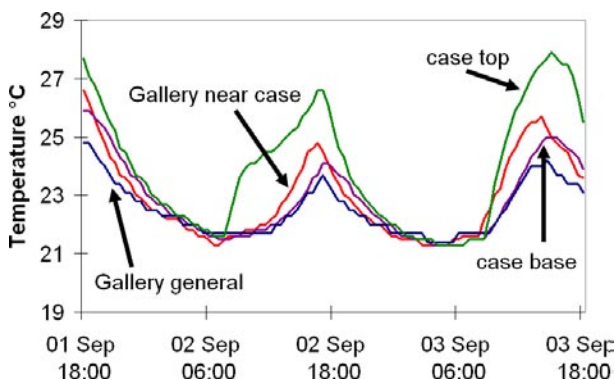

Figure 9. Variation in temperature inside Reveal case S at the top and base, and between gallery locations in the vicinity of case S, and remote from the case.

Measurement conditions	AER	AER	AER
	– night	– day	24 hours
Case lights on 7:30 – 17:00 gallery ventilation on 24 hrs	1.1	4.9	2.5
Case lights on 7:30 – 17:00 gallery ventilation off	0.8	4.4	2.3
Case lights off Gallery ventilation on 24 hrs	1.4	1.2	1.3
Case lights off Gallery ventilation off	1.0	1.0	1.0

Table 1. Variation in the air exchange rate of Case S in the Reveal gallery. All measurements are air changes per day (ac day⁻¹).

Temperature inside the case and in the ambient gallery environment was recorded during the air exchange rate measurements. Dataloggers were placed inside the case at the top and bottom to measure the temperature gradient within the case during the first test, when case lighting and ventilation systems were operating normally. These measurements showed that when the case lighting was on, the temperature at the top of the case was 2.5–3°C warmer than the temperature at the base of the case (Figure 9). At the top of the case, diurnal fluctuations of 5–6°C were measured during the air exchange rate tests. The temperature differential between the top of the case and the ambient gallery environment in the vicinity of the case varied from less than 0.5°C at night when the lights were off, to 2°C with the case lighting switched on.

In a gallery development project, case air exchange rate measurements are frequently carried out before the case lighting systems are operating normally, so such measurements are of doubtful usefulness. Since an idea of the air exchange rate of a case is important for calculating the quantity of buffering material needed, it is helpful to have a realistic measurement of the air exchange rate of a case within a normal gallery environment, rather than a measurement made in unrealistic conditions with no ventilation or lighting. It is clear that the air exchange rate of these cases, once the impact of lighting systems is taken into account, is even further from the specification than indicated in Figure 3.

One action that has been agreed for the cases is to place additional insulation materials between the fibre optic projector and the base of the light box, to minimise the heat radiated into the case volume. The impact of fibre optic lighting systems on case leakage is not limited to the problems of heat generation: even if the projectors are located remotely and are well insulated, the tails for fibre optics will invariably puncture the microclimate,

with a potential increase in the air-exchange rate. The point where the tails enter the case volume can be well-sealed initially, but there is the risk that the sealant will deteriorate over time, and the leakage rate of the case will increase [7].

SPECIFICATION OF MATERIALS FOR SHOWCASES

The requirement to specify inert construction materials to reduce the emission of reactive volatile components causing collections to deteriorate is well understood. There are clear guidelines and a standard testing procedure for materials [10] is routinely used to screen case construction and dressing materials before they are approved for used.

However, in practice the choice of materials is not straightforward. To begin with, the main inert materials used in case construction (metal, glass, Perspex) offer comparatively little buffering capacity, so there is already a compromise between an inert environment and a well-buffered environment. Powder-coated steel as a case lining is less likely to produce harmful organic acids than MDF or other wood products, but it is much more difficult to fix to, and therefore not popular with designers wishing to display objects fixed to the back or sides of a case.

National Museums Liverpool's case specifications list our required curing and off-gassing periods for coatings and sealants. However, even when all materials have been tested and approved, the cases invariably have a strong solvent smell when they are installed – perhaps because curing times are difficult to police when plinths and case linings are manufactured off site. The original programme had an allowance of two weeks for the cases to ventilate, with the doors open, once constructed. This became very difficult to enforce with so many other activities taking place on the gallery.

Concentrations of organic acids were measured in the Into the Future sample cases, and in some of the final cases before the plinths and objects were installed, and were found to be well within the “no observable adverse effect level” suggested by Tétrault et al for the corrosion of lead and copper in the presence of organic acids [11]. However, when concentrations were measured again two to three years later, some cases had high levels of acetic and formic acids. Possible sources include the objects themselves, or the plinths and stands which were constructed from MDF sealed with a two part polyurethane coating.

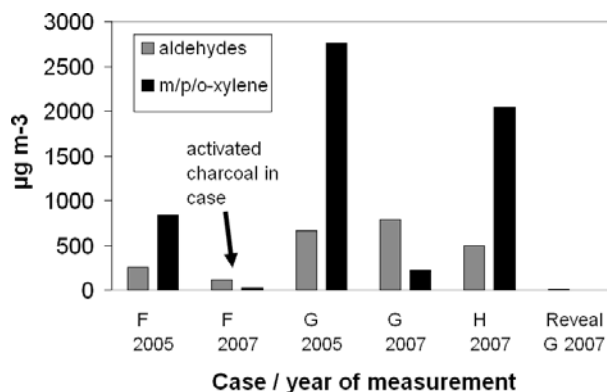

Figure 10. Concentrations of aldehydes (formaldehyde and acetaldehyde) and xylene (total m/p/o-xylene) in showcases. Cases F and G were monitored soon after installation (2005), and two years later (2007). Case H was monitored 2 years after installation. The Into the Future cases were specified to have an air exchange rate of 0.1 ac day⁻¹, although this was not confirmed through testing these cases. Reveal case G had a measured air exchange rate of 1.5 ac day⁻¹, and the aldehyde and VOC concentrations were monitored 9 months after installation.

Concentrations of aldehydes and total volatile organic compounds (VOC's) of the Into the Future Cases were measured shortly after the cases were constructed, but before the objects were installed. Relatively high levels of VOCs, especially xylene and aldehydes were found in the cases (Figure 10). The concentrations were measured again two years later. Activated charcoal had been placed in one of the cases, (case F), as a scavenger for pollutants, and this appears to be successful in reducing concentrations. In cases without any pollutant scavenger, concentrations remain relatively high two years after installation. Case H had not been part of the initial study immediately after construction, but was included because curators had noted that it had a very strong solvent smell, and two years after installation, xylene concentrations were still over 2000 µg m⁻³.

By contrast, the concentrations of VOCs measured in the comparatively leakier Reveal cases were very low one year after installation, even though the initial perception was that there was a strong solvent smell when they were installed. One advantage of the cases failing to meet the air tightness specification is that they allow any volatile products emitted by sealants and finishes to disperse. The dilemma that we now face is how to undertake remedial works to improve the air-tightness of the cases, which may mean applying sealant to cases with collections in situ. This is a problem that is sometimes encountered in the run-up to a gallery opening. When air-tightness testing finds gaps in the case days before object installation is due to take place and additional sealant needs to be applied, do

you prioritise an air-tight case over one where all the volatile components have dispersed?

The comparative risk to a collection from a leaky case and pollutants needs to be assessed. For some internally generated pollutants, such as the VOCs measured in the Into the Future cases, these risks are difficult to assess when little is known about the likelihood of damage to collections at particular concentrations. Metal coupons exposed in Into the Future case G for 32 months showed some tarnishing of the silver coupon, and darkening of the lead coupon, compared to control coupons kept in the laboratory for the same duration. A survey of metal objects in the Into the Future cases 24-32 months after installation showed no significant effect from the high levels of VOCs.

PROJECT MANAGEMENT AND COMMUNICATION

The examples given above illustrate that the way a project is managed affects the ability to procure a product that meets the specified requirements. Stanley et al [12] discuss the benefits of having a conservator in a key role in the project team, and the importance of ensuring that all parties accept the technical specifications and understand their implications for the programme. National Museums Liverpool's specifications were developed by a cross-functional team with input from all departments, and following widespread consultation with external colleagues. One of the factors that may have contributed to the problems we encountered is that the project team changed completely part way through the Into the Future project, and the new team had not been involved in the development of the original showcase specifications or the original tender process.

Programmes drawn up at the beginning of a project usually have a generous allocation for commissioning and ventilation of cases and off-gassing of sealants. However, since the off-gassing time is towards the end of the programme, it is very vulnerable to compression when a fixed opening date is looming, with dignitaries booked. Frequently this period ends up being used to absorb the slippage of other elements, which may be incompatible with the dust-free environment needed to allow cases to vent with doors open. We now avoid the use of solvent-based paint finishes in showcases, even if accelerated corrosion tests indicate that the cured finish is relatively inert. If the finishes are applied off-site, it is very difficult to ensure that they have been cured for the recommended time in a well-ventilated environment.

The specifications have been updated and revised following the Reveal project, and the appointment process for a showcase contractor now includes a detailed session to examine the technical specifications and discuss difficulties and queries. Over the next 3 to 4 years, National Museums Liverpool is undertaking a further series of major development projects, and one of the challenges will be communicating the lessons learned to the different external consultants appointed to each project.

CONCLUSIONS

This paper highlights some of the practical problems encountered when applying knowledge of microclimates to specifying museum showcases, and the compromises needed to satisfy different aspects of the microclimate. The development of a method for testing air-exchange rates that can be used in-house to test every case installed in a new gallery doesn't necessarily result in more air-tight cases. More important is the management of the project, to ensure that the specifications and their implications are understood, and to allow time for testing and development at an early stage of the project. Programmes for testing cases and measuring air exchange rates need to take account of factors such as the case lighting systems and gallery ventilation, to predict the air-exchange rates that will actually be achieved once the cases are in an operating gallery.

There are certain risks associated with specifying air-tight cases that need to be communicated and understood. An understanding of the comparative risks to objects from a leaky case or from internally generated gaseous pollutants is important. Ongoing research on the interaction of these pollutants with museum objects [13] has a significant contribution to make to the specification and procurement of museum showcases.

AUTHORS

Siobhan Watts, David Crombie, Sonia Jones
and Sally Ann Yates
National Museums Liverpool
National Conservation Centre,
Whitechapel,
Liverpool, L1 6HZ
Fax: +44 151 479 4990
Siobhan.watts@liverpoolmuseums.org.uk

REFERENCES

- 1 Cassar, M. and Martin, G. 1994 The environmental performance of museum display cases. In A Roy and P Smith (eds.) Preventive conservation: practice, theory and research. Preprints IIC Ottawa Congress. London: International Institute of Conservation, pp. 171-173
- 2 Potter, I.N. and Jones, T.J. 2001 Results of ventilation measurements on five display cases within the Conservation Centre, Liverpool. Report 16090A. BSRIA Ltd., Old Bracknell Lane West, Bracknell, Berkshire, RG12 7AH, UK.
- 3 Calver, A, Holbrooke A, Thickett, D and Weintraub, S. 2005 Simple methods to measure air exchange rates and detect leaks in display and storage containers. In I Verger (ed.) Preprints ICOM-CC 14th Triennial Meeting Le Hague. London: James and James, pp. 597-609
- 4 Dr. Simon Watts, School of Biological and Molecular Sciences, Oxford Brookes University, Headington, Oxford, OX3 0BP, UK.
- 5 Gibson, L.T., Cooksey, B.G., Littlejohn, D. and Tennent, N.H. 1997 A diffusion tube sampler for the determination of acetic acid and formic acid vapours in museum cabinets. *Analytica Chimica Acta* 341, pp 11-19
- 6 Tétrault, J. 1994 Display Materials, The good, the bad and the ugly. In J.Sage (ed.) Exhibitions and Conservation. Preprints of the Conference held at the Royal College of Physicians, Edinburgh. SSCR pp 79-87.
- 7 Thickett, D., David, F. and Luxford, N. 2006 Air exchange rate – the dominant parameter for preventive conservation? *The Conservator* 29 pp.19-34
- 8 Michalski, S. 1994 Leakage prediction for buildings, bags and bottles. *Studies in Conservation* 39, pp. 139-186
- 9 Bacon, L. and Martin, G. 2000 Out of Africa! Display case strategies – the theory and the reality. In A Roy and P Smith (eds.) Tradition and innovation. *Advances in Conservation*. Preprints IIC Melbourne Conference. London, International Institute of Conservation, pp. 18-23.
- 10 Green, L.R. and Thickett, D. 1995 Testing materials for the storage and display of artefacts – a revised methodology. *Studies in Conservation* 40 pp. 145-152.
- 11 Tétrault, J., Cano, E., van Bommel, M., Scott, D., Dennis, M., Barthés-Labrousse, M. and Robbiolo, L. 2003 Corrosion of copper and lead by formaldehyde, formic acid and acetic acid vapours, *Studies in Conservation* 48, pp 237-250.
- 12 Stanley, B. Xavier-Rowe, A. and Knight, B. 2003 Displaying the Wernher collection: a practical approach to display cases. *The Conservator* 27 pp 49-56.
- 13 Cost Action D42 Chemical Interactions between Cultural Artefacts and Indoor Environment (ENVIART) <http://www.echn.net/enviart/> accessed 26.04.2007



This work is licensed under a Creative Commons Attribution - Noncommercial - No Derivative Works 3.0 Licence.

THE USE OF GLASS BOXES TO PROTECT MODERN PAINTINGS IN WARM HUMID MUSEUMS

FRANCIZA TOLEDO, MAGALI SEHN, MÁRIO SOUSA JÚNIOR, SÉRGIO BRAZOLIN AND STEPHEN HACKNEY

ABSTRACT

This paper considers the advantages and disadvantages of an enclosure for the display of unvarnished easel paintings, both modern and contemporary, for use in warm, humid museums. Microclimate analyses of a display box's performance in five museums are presented and correlated with material damage to paintings. The results are presented of a research project, carried out between 2000 and 2002, to test a sealed glass box at five Brazilian, naturally ventilated museums and to verify its efficacy in protecting paintings, not only to avoid soiling and consequent cleaning of their surfaces but also to reduce biological attack, particularly that caused by fungi.

INTRODUCTION

This research resulted from a discussion among Brazilian conservators on the efficacy of using glass boxes for the exhibition and conservation of modern paintings in Brazilian museums, during a workshop conducted by Stephen Hackney (Tate, London), supported by Fundação Vitae, a Brazilian private sponsoring body, in 1999. It aimed at testing a simplified type of box and evaluating its performance as a protective device for unvarnished paintings. The box was tested in five museums in Brazil, all naturally ventilated, in three regions of the country with distinct climates: Northeast, Southeast and South of Brazil. The host museums were the following: Museu de Arte Contemporânea de Pernambuco (MAC-PE), in Olinda, Museu de Arte Contemporânea da Universidade de São Paulo (MAC-USP), in São Paulo, Museu de Arte Moderna (MAM-RIO), in Rio de Janeiro, Museu de Arte da Pampulha (MAP-BH), in Belo Horizonte, and Pinacoteca Barão de Santo Ângelo (PINA-POA), in Porto Alegre, Rio Grande do Sul.

Physical protection and stability of museum objects is achieved by enclosures of many types. However, it is common knowledge that, in warm and humid climates, each and every thing that is kept in cabinets, drawers and boxes grows mold. In fact, biodeterioration, fungal outbreaks in particular, is one of the major conservation problems faced by Brazilian museums' staff. During the workshop,

conservators reported that unvarnished paintings aged quickly, particularly if exhibited in naturally ventilated museums. Surfaces darken with dust, losing colour saturation, and potentially hazardous surface cleaning becomes necessary.

The argument put forward by Stephen Hackney at the workshop was that in temperate climates protection of modern paintings by enclosure behind glass brings benefits, preventing them from dust accumulation, soiling, premature aging [1] and large daily climate fluctuations [2] and the debate was whether this protection could be extended to museums with high temperatures and humidity and consequent tendency for mould growth.

Some researchers state that fungal outbreaks are due to sporadic rises of air temperature and relative humidity [3]; others relate them to constantly high levels of relative humidity, corresponding to a high 'water activity number' [4] [5]. Other researchers anecdotally correlate mould growth with a combination of moist and dirty surfaces [6]. During the development of its ten-year program in Sub-Saharan African countries – Prevention in Museums in Africa, the International Centre for the Study of the Preservation and Restoration of Cultural Property – ICCROM staff observed that fungal spores would not germinate on clean surfaces. In some African museums, both objects and shelves, after being thoroughly cleaned, were enclosed by polyethene sheets fixed with *Velcro* to the furniture structure. Most of them have remained free of biodeterioration.

It is interesting to note that while easel paintings are directly exposed to indoor environmental conditions, works of art on paper, due to their apparent fragility, have their fronts protected by glass, and their backs by cardboard or other inadequate, porous, normally acidic materials. This type of protection allows humidity from the walls to penetrate those back supports and cause mould to appear, first on the inner glass surface, where condensation may occur, then on the *passe-partout* (the card mount), and finally on the art work itself. Therefore the experience of framing visual art in warm humid museums had failed in Brazil in the past.

The use of glass boxes to protect modern, unvarnished paintings also raises aesthetic problems. Artists, curators and ordinary museum-goers seem not to appreciate observing works of art through glazing. Light reflects on the glass surface, producing glare and preventing the observer from identifying and enjoying artistic materials and techniques. In this research, the aesthetic drawbacks of glazing modern and contemporary paintings are not discussed, and the performance of the glass boxes is analysed simply on their ability to stabilize indoor climate daily fluctuations and prevent surface mould growth. Therefore an attempt was made to correlate both sporadic climatic extremes and also long periods of constantly high temperature and relative humidity with mould growth on painting replicas.

METHODOLOGY

Because it was a national project, involving five institutions in five states of Brazil, some logistical issues were addressed prior to the design concept and construction of the glass box. Aiming at a smooth development of the research project, the authors undertook the following: 1) theoretical and conceptual discussions; 2) definition of the design and materials to be used in the glass box; 3) definition of the materials to be used in the painting replicas; 4) selection of the monitoring equipment; 5) microbiological analysis to be carried out, before and after the boxes were exhibited in the five museums, to be undertaken by the Instituto de Pesquisas Tecnológicas – IPT in São Paulo; and 6) data analysis, correlation and conclusions on glass enclosures in warm humid museums.

The box was intended to be sent to the museums and be exposed there for one year, completely unattended, without any type of maintenance. The box design and construction were very simple: two 4mm glass panes on its front and back, held together by a wood frame, a sliding plywood (10mm) stretcher with the six painting samples, sealed together with caulk. Holes were drilled around the stretcher to facilitate air mixing between front and back of the box. The relationship between air moisture content and that of the organic buffering materials inside the box was calculated [7][8] based on the space necessary to insert the small NOVUS datalogger. A set of six unprotected painting replicas was exhibited next to the set protected by the glass box.

The most popular and vulnerable painting materials, particularly to microbial attack, were selected for the mock-ups. Six different painting techniques

were tested, with and without ground or preparation layer: 1) oil, 2) acrylic emulsion, 3) vinyl emulsion, 4) egg tempera, 5) mixed media (oil, acrylic and paper glued on canvas), and 6) mixed media (acrylic on paper glued on *Eucatex*). The paintings were simple stripes of primary and black and white colours. A set of replicas was kept in the laboratory, in controlled conditions, for later comparison purposes. Ready-made acrylic paints *Acrilex* were utilized, being available in many colours, of good colour rendering, cheap and easily found in the local market. However, for the other painting techniques to be tested, some imported pigments (*Prisma*) had to be purchased. The most popular supports were also chosen: cotton canvas (that could be tensioned on a stretcher, plywood or wall); *papier collé* (*Kraft* paper glued on textile); and *Eucatex* (a hard and lightweight wooden panel that accepts various painting techniques). For the preparation layer, white *Suvinil* ground paste was used. Twelve prototypes were made: six were exhibited inside a well sealed glass box and the other six were exhibited without protection.

Before sealing the box, its interior glass panels were cleaned and sterilized with alcohol (ethanol). Painting surfaces were sampled for fungi by IPT staff, at three points: egg tempera, vinyl emulsion and the plywood stretcher. Under laboratory conditions, mould grew on the vinyl emulsion of the MAC-USP and MAM-RIO, and on the egg tempera of the MAC-PE and the PINA-POA. The potential for mould growth was observed in all egg tempera samples exhibited without glass protection. 7 types of fungi were isolated.

Two dataloggers were attached to the box: one inside and the other outside it. The monitoring of air temperature and relative humidity values lasted one year, from April 2001 through March 2002. The dataloggers had to be wireless, operating by battery, be resistant, accurate, and the data downloaded without opening the box (by infra-red emission)¹. The equipment was manufactured by and purchased from NOVUS Produtos Eletrônicos, a Brazilian company that uses the English technology of Tiny Tags. They were programmed to register an average of 5 readings, taken every 15 minutes, with just 19 daily readings, with the hours coinciding each 5 days. The averaging, meant to save memory, in fact smoothed the curve, missing some extreme climate values.

Because of the long monitoring interval established by the conservators in the first year, as well as the

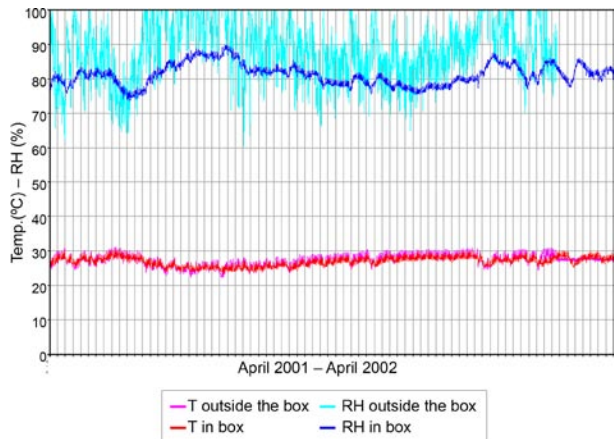

Figure 1. annual graph with collected climatic data at MAC-PE, a massive building, showing the high indoor RH. There is frequent condensation on the wall of the upper exhibition room where the glass box was hung.

large number of painting replicas (and therefore variables to take into account), the experiment was considerably simplified, according to recommendations made by Stephen Hackney, in September 2002, when all the authors met in Rio de Janeiro, and since September 2006 it has been repeated in Recife, by Franciza Toledo. The box is in her living room, sitting next to an interior wall perpendicular to the glazed east facade, and daily exposed to the morning sun. The dataloggers were then programmed for hourly readings. The painting replicas of the first experiment were replaced by a piece of cotton canvas, stretched and partially coated with animal (rabbit-skin) glue, with and without fungicide. The results of this research in progress will be the subject of another article.

RESULTS

Out of the five experiments carried out between 2001 and 2002, three failed in data collection because three exterior dataloggers became faulty. Therefore only data from experiments undertaken at MAC-PE, in Olinda, northeast Brazil, and MAC-USP, in São Paulo, southeast Brazil, are discussed in depth. The experiments conducted at MAP-BH, in Belo Horizonte, MAM-RIO, in Rio de Janeiro, and PINA-POA, in Porto Alegre, are discussed in a general way. Summer and winter climatic data were processed, to determine the average values of temperature, relative (RH) and absolute humidity (AH) of air, inside and outside the boxes, and to evaluate its performance.

The Museu de Arte Contemporânea de Pernambuco – MAC-PE occupies an 18th century two-storey massive building in Olinda, a world heritage site. It was originally built to house a religious prison and still maintains its original features: the windows

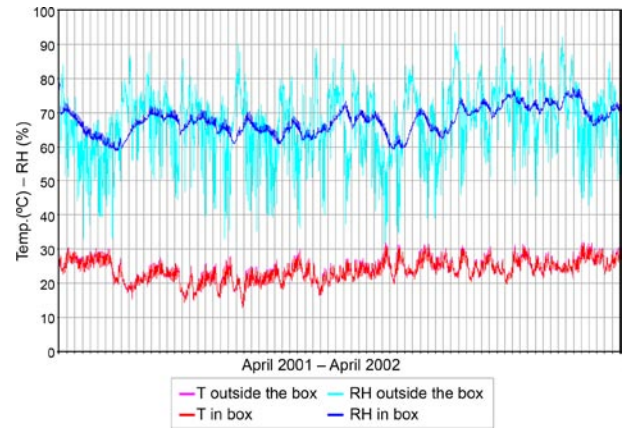

Figure 2. annual graph of the collected climatic data in the MAC-USP museum corridor, showing five-day large fluctuations both of temperature and RH values.

do not have shutters, just rails, being permanently cross-ventilated, and the upper rooms do not have ceilings. The boxes were exhibited on the upper, first, back room. Being a constantly open museum, the MAC-PE presented a large daily climate variation of $\pm 7\%RH$ and $\pm 1.3^{\circ}C$. The box reduced the variation to $\pm 1\%RH$, while interior temperature variation values approached those of the exterior ($\pm 1^{\circ}C$). Next to the wall there was frequent air saturation and condensation, while the RH inside the box remained high, around 81%. The RH near the wall varied between 90% and 100%, while inside the box it varied between 85% and 90%. In the rainy winter the average climate values inside the box were 83%RH and 25.6°C and in the dry summer, 80%RH and 27.8°C. The absolute humidity next to the wall was 19g/kg in winter and 21g/kg in summer. Inside the box, it ranged from 16.5g/kg to 18.5g/kg in winter, while in summer it increased, ranging from 18g/kg to 20.3g/kg (fig. 1).

The Museu de Arte Contemporânea da Universidade de São Paulo – MAC-USP is housed in a modern, modular concrete building at the university campus. The box was hung in a corridor between the museum administration and exhibition rooms, characterized by a large movement of people and climatic instability. The RH daily fluctuation next to the wall at the MAC-USP was about $\pm 8.5\%$, while temperature varied about $\pm 2.2^{\circ}C$. The box reduced the RH fluctuation to $\pm 1\%$, while temperature variation was similar ($\pm 2^{\circ}C$). Both average temperature and RH values, inside and outside the box were similar, around 24°C and 67%RH. Inside the box, the RH average value in the dry winter was 66% and in the rainy summer 71%. Temperature inside the box, in winter, was 22.5°C and in summer, 25.6°C. Still in summer, the absolute humidity next to the wall was 14g/kg to 15g/kg, while inside the

box it varied from 13.5g/kg to 15.5g/kg. In winter, the absolute humidity reduced, the inside values ranging from 10 to 13g/kg, and the outside ones from 11 to 12g/kg (fig. 2).

At the Museu de Arte Moderna do Rio de Janeiro – MAM-RIO, a modern concrete building from the 1950s, designed by architect Afonso Eduardo Reidy, in Flamengo Beach, exterior temperature readings were corrupted in winter time, and remained high, while the inside temperature reduced by about 4°C (in September and October 2001, the average temperature inside the box was 24.6°C and that of the outside, 28.6°C). The interior RH average value was 72%, while the exterior RH varied between 62% and 83%. Towards the rainy summer, exterior RH readings decrease instead of increasing, confirming the inaccuracy of the equipment. Next to the wall, the microclimate varied just $\pm 3\%$ RH, and the box contributed to enhance this stability, presenting interior daily fluctuations of $\pm 0.75^\circ\text{C}$ and $\pm 0.75\%$ RH. In February and March 2002, the RH inside the box was about 76%, while the exterior ranged from 53% and 81%. The average temperature inside the box was 28.3 °C, but reached 32.4°C (on 03.20.02 at 17:45). The glass box was exhibited in the museum entrance hall.

At the Museu de Arte da Pampulha – MAP-BH, in Belo Horizonte, a concrete and glass building, designed by Oscar Niemeyer in the 1940s, the exterior climate data were corrupted after July 5, 2001. However, the climate conditions inside the box, hung on an exterior wall of the museum's mezzanine, showed a constantly hot environment, which led to a gradual air drying process, with the interior RH values being reduced from 72% to 55% at the end of the year. In the first three months of the dataloggers simultaneous operation, both inside and

outside temperatures dropped 2.5 °C and while the outside RH raised to 78%, the inside one remained stable at about 72%. In this short period, the outside temperature and RH variations were $\pm 0.25^\circ\text{C}$ and $\pm 2\%$ RH, and the inside ones, $\pm 0.3^\circ\text{C}$ and $\pm 0.4\%$ RH. The inside temperature values were slightly higher (0.7°C) than that of the outside, the average value being 28.7°C, reaching 32.6°C in various occasions. In the dry winter, the absolute humidity inside the box varied from 17.5g/kg to 15.2g/kg, and in the rainy summer, it was about 13.7g/kg.

At the Pinacoteca Barão de Santo Ângelo, which is housed in an ordinary building from the 1940s, in the center of Porto Alegre, the exterior climate data were also corrupted. The box was hung on an internal wall of one of the exhibition rooms on the second floor. The average temperature inside the box was 22.5°C and the RH, 78%. Between September and October 2001, the average RH was about 85% and temperature, 21°C. In January and February 2002, the RH was 73%, and the temperature, 26.4°C, reaching 29°C (on 01.30.02 at 20:00). Interior temperature and RH daily fluctuations were $\pm 0.6^\circ\text{C}$ and $\pm 0,5\%$ RH. The lowest absolute humidity value occurred in the rainy winter, with an average of 11.5g/kg, and the highest, in the dry summer, with an average of 15g/kg.

Concerning the annual RH average values inside the boxes, it was observed that the MAC-PE presented the highest (81%), followed by the PINA-POA (78%), MAM-RIO (73%), MAC-USP (67,5%) and MAP-BH (63%). The latter presented the highest temperature average value (28.7°C), followed by MAC-PE (27°C), MAM-RIO (26.9°C), MAC-USP (23.8°C) and lastly, PINA-POA (22.5°C). The most stable microclimate was found at the MAP-BH, followed by the PINA-POA. The most unstable

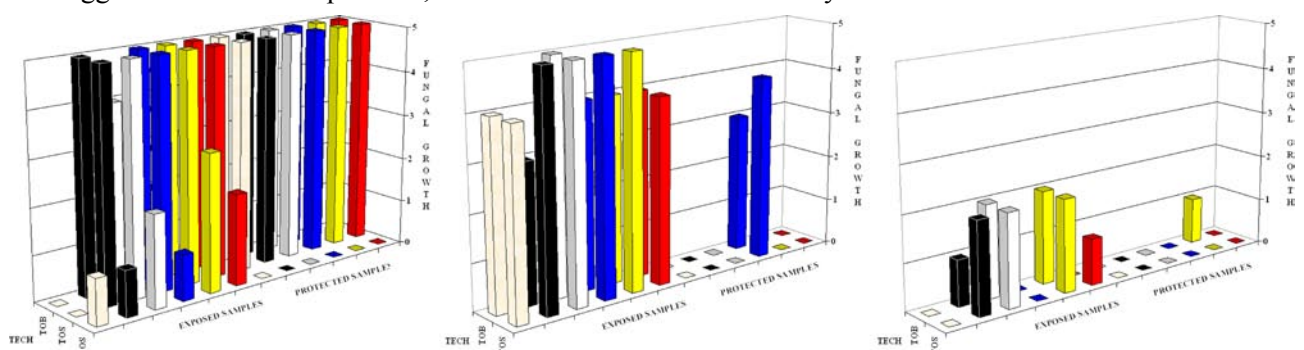

Figure 3. microbiological analysis of the egg tempera painting replicas exhibited at the MAC-PE (left), PINA-POA (center), and MAM-RIO (right). The colours in the graphs represent the stripes and the beige represents the canvas without paint. Axis X shows the two sets of replicas without and with the protection of the glass box. Axis Y shows the degree of mould growth: 0 - no growth, 1 - signs of growth, 2 - 1 to 10% of growth of the total area of the colour stripe, 3 – over 10% up to 30% of growth, 4 – over 30 % up to 70% of growth, and 5 - more than 70% of growth. Axis Z shows the egg tempera replicas with (TOB) and without (TOS) the preparation layer; at the MAC-PE (left graph), the oil on canvas painting replica, without preparation layer (OS), in the third row, also grew mould. Source: IPT report n° 63.058.

climate conditions were registered at the MAC-USP and MAC-PE. The highest absolute humidity values were registered at the MAC-PE (18.3g/kg), followed by the MAM-RIO (16.5g/kg), MAP-BH (15.5g/kg), PINA-POA (13.4g/kg) and MAC-USP (12.6g/kg).

The boxes were collected at the IPT, on April 11 to 18, 2002, for microbial examinations: quantification and identification of fungi. The painting replicas displayed without the protection of the glass box were visibly soiled and presented, aside from the stains caused by fungal attack, wall or ceiling paint drops, bats and insects' excrements, surface darkening and dust accumulation, as well as structural damages such as undulations, fissures and paint losses. Such decay was considerably attenuated in the samples displayed in the glass boxes. The technique most susceptible to decay was the egg tempera, followed by the two mixed media: acrylic paint on Kraft paper glued to Eucatex, and oil and acrylic paint on Kraft paper glued to canvas.

After one year, the fungal contamination increased, with 21 new fungi being identified. Yeasts and bacteria were also identified. Three out of the five pairs of boxes developed mould, but microbial contamination was higher on the replicas exhibited without protection. The following was observed: a) canvas, plywood and paper favoured microbial deterioration; b) the ground used was less susceptible to fungi; c) egg tempera and oil painting (without ground), particularly on the black and white colours, were the most vulnerable to fungal attack. The replicas from MAC-USP and from MAP-BH were clean, while those of MAC-PE, PINA-POA, and MAM-RIO presented microbial contamination, in an incipient manner on the third, and widespread on the first and second sets of replicas (fig. 3).

CONCLUSION

The results showed that, in warm humid museums, a glass box, if well built, is efficient in creating a safe microclimate and protecting exhibited paintings from microbial deterioration. The glass boxes presented many advantages: 1) climatic stability due to a good sealing and a certain amount of buffering materials; 2) microbial control; 3) dust control; 4) extra protection for works on loan; and 5) UV radiation control, if UV filters is applied to the glass. The disadvantages were: 1) visual interference; and 2) its incompatibility with some conceptual works of art.



Figure 4. painting replicas exhibited with (left) and without (center) the protection of the glass box at the MAC-PE, and details (right) of the egg tempera samples protected by the glass (above) and unprotected (below).



Figure 5. painting replicas exhibited with (left) and without (center) the protection of the glass at the MAC-USP, and details (right) of the mixed media - acrylic, oil and Kraft paper on canvas samples, protected by the glass box (above) and unprotected (below), showing the paper undulations.

The glass box may be recommended for: a) works of art with thin painting layers sensitive to daily climate fluctuations and prone to mechanical damages; b) works with rich, porous painting layers, such as temperas; c) monochromed works, on which any type of surface cleaning is problematic; d) old, fragile or heavily soiled works; e) works that are constantly handled and/or on loan.

It should not be used on: a) works of art composed of slow drying materials (such as oil, paraffin, vaseline, etc.); b) varnished works; c) works with thick impasto paint or reliefs; d) conceptual works that require exhibition as they are; and e) works of large dimensions due to risk of glass breakage.

To work properly the glass box requires: a) minimal sealing, with tape, silicone or caulk; b) minimal sterilization; c) the use of dry organic buffering materials in the enclosure; d) interior air absolute humidity lower than that in equilibrium with the moisture content of the enclosed materials; e) the use of chemically inert materials. However, more investigation is needed on: a) the use of thermal insulation materials as backings; b) the use of lighter materials; c) painting surfaces changes (colour and texture); d) air diffusion rate and hygrometric half-time of the glass box; and e) smaller and more reliable monitoring equipment.

ACKNOWLEDGEMENT

This research project was possible thanks to the financial support of Vitae Apoio à Cultura, Educação e Promoção Social.

AUTHORS

Franciza Toledo.
Conservare Consultoria em Tecnologia de Conservação. Rua de Apipucos, 1230. Recife/PE. 52.071-000.
franciza_toledo@uol.com.br

Magali Sehn. MS
Preservação de Acervos de Arte. Rua Bela Cintra 261/02. São Paulo/SP. 01.415-000.

Mário Sousa Júnior.
CECOR/EBA/UFGM. Av. Antônio Carlos, 6627. Belo Horizonte/MG. 31.270-901.

Sérgio Brazolin.
Instituto de Pesquisas Tecnológicas do Estado de São Paulo – IPT. Av. Prof. Almeida Prado 532. São Paulo/SP. 05.508-901.

Stephen Hackney.
Tate Gallery. Milbank, London. SW1P 4RG.

REFERENCES

- 1 HACKNEY, S., J. Townsend and N. Eastaugh (editors). *Dirt and Pictures Separated*. UKIC, 1990. p. 56. 12 papers.
- 2 MICHALSKI, Stefan. 'Relative humidity: a discussion of correct/incorrect values'. In: *Preprints of ICOM-CC 10th Triennial Meeting*. Washington, 1993. p. 614-619.
- 3 HACKNEY, Stephen. Data analysis and discussions with him about the results, in two meetings: September 22 and 26, 2002.
- 4 VALENTÍN, Nieves et al. Microbial control in archives, libraries and museums by ventilation systems. In: *Restaurator*, v. 19, n. 2. 1998. p. 85-107.
- 5 FLORIAN, Mary-Lou. *Heritage Eaters – Insects and Fungi in Heritage Collections*. London: James & James, 1997.
- 6 De GUICHEN, Gaël. Conversation with him about ICCROM's Prevention in Museums in Africa – PREMA, and how museum buildings (storages and exhibition spaces) were approached in the training program, in November 2006.

7 HACKNEY, Stephen. Correspondence via email from 2000 to 2002.

8 THOMSON, Garry. Relative humidity: variation with temperature in a case containing wood. In: *Studies in Conservation*, n. 9. 1964. p. 153-169.

9 The boxes at the MAC-PE presented the highest level of microbial deterioration (fig. 4) followed by the ones exhibited at the PINA-POA. At the MAC-USP (fig. 5) and MAM-RIO, the mixed medias, with paper strips glued as collages, presented fissures and undulations. In sum, within a year, the painting replicas exhibited in constantly high air relative humidity developed mould while the ones that underwent daily large fluctuations suffered mechanical damages



This work is licensed under a Creative Commons Attribution - Noncommercial - No Derivative Works 3.0 Licence.

TRENDS IN MICROCLIMATE CONTROL OF MUSEUM DISPLAY CASES

JERRY SHINER

This historical review of microclimate control in museum display cases reflects the changes in approach to museum microenvironmental control that have arisen with new technologies over the past hundred years. A variety of approaches to controlling the environment within display and storage cases has been developed. An explanation of these various microclimate control techniques is provided, with an emphasis on recent developments in active microclimate control systems.

INTRODUCTION

When a society elevates an object to a symbol, demands arise for its safe handling and preservation. Whether simply stored or fancifully displayed, we design and create environments to protect these objects from known threats. Our ability to protect artefacts from harm is always trailing just a little behind the ever accelerating developments in the analysis of the world around us. The microenvironmental control methods we use constantly change as our technologies and analytical techniques expand.

ANCIENT HISTORY

Museum display case microclimates involve enclosures, and this survey must start with the development of the museum enclosure itself. Some cite the Ancient Greeks as the first to record ideas on the design of storage facilities, where practical consequences of orientation and construction on the environment are discussed. However, the most obvious examples of purpose-built storage structures are in Egypt. Primarily seen as impressive symbols of power, the architects of the pyramids also attempted to protect the materials they enclosed by incorporating environmental control. Whether by chance or good design, these massive tombs have maintained fairly constant environmental conditions within them over millennia.

MUSEUM MICROCLIMATES

A microclimate is an environment that can be clearly defined (both by measurements of the environment, and by location). For our purposes a microclimate is usually a contained space, such as the burial chamber of a pyramid, a museum gallery, or a storage or display

cabinet. Enclosure isolates the inner (microclimate) environment from the outer (ambient) environment.

While a museum gallery's roofs and windows may reduce levels of pollutants, inclement weather, and daylight, they may also create pockets of dangerously high or low humidities, off-gassed pollutants, and over-illumination. Similar situations can be produced by any successive barrier system incorporated into the larger ambient environment. The establishment of any microclimate becomes a two-edged sword, its benefits usually obvious, and its dangers often less apparent. The history of display case microclimates is rooted in the mechanics of creating display cases, the development of appropriate methods of controlling the case environment, and the technical innovations applied to microclimate control.

CREATING THE MODERN DISPLAY CASE

By the middle of the nineteenth century, modern industry was providing relatively inexpensive and easy to assemble materials. The Crystal Palace, built in 1851 in London, exemplified the new Age of Industry. Created almost entirely of iron and glass, the structure used glass sheets 49 inches square fitted with tolerances close enough to create an essentially leak-proof roof. Architecture had provided the model for the modern display case.

NINETEENTH CENTURY MICROCLIMATE CONTROL - THREATS AND RESPONSES

By the middle of the nineteenth century, it was recognized that pollution from burning coal gas was harming the leather bindings in London's libraries, as well as the paintings in the National Gallery. An architectural response to the problems of indoor pollution from burning gas for illumination was to increase ventilation to exhaust the soot and toxic gases. While air borne pollution was a relatively new problem, dampness (a factor in metal corrosion and the growth of moulds) had long proved more of a challenge for microclimate control. Beyond the use of building heat to reduce humidity on cold and damp days, true control of a building's humidity levels would need to wait until the early twentieth

century for large scale mechanical solutions. Smaller scale microclimate solutions would have to wait even longer.

By 1850 the National Gallery in London was glazing paintings to protect them from airborne pollutants. One of the earliest references to a sealed enclosure especially designed to create a microclimate environment is an 1892 patent [1] for a sealed case used to protect a painting by JMW Turner in 1893. When originally sealed into the patented enclosure, the Turner painting was perceived as the most deteriorated of a group. The painting has remained undisturbed in the case since then, and when compared to its companion paintings, all of which have been conserved during the last hundred years, it now looks to be in far better condition! [2]

EARLY TWENTIETH CENTURY DEVELOPMENTS

In 1932, another patent was awarded [3] for a museum case providing passively controlled humidity levels. As in the earlier example, this patent again specified the use of a very well-sealed case but also incorporated a tray of saturated salts. As long as the case remained sealed, and the temperature remained stable, the mixture of salts would maintain a constant relative humidity by passively buffering the moisture content of the air. A case using this system was used in the National Galleries of Scotland for the containment of a sensitive altar piece, and provided control to within 1% of the relative humidity target. [4] Saturated salt solutions were occasionally used for microclimate control in larger applications, and were still being considered in the early 1990's as an effective means of maintaining enclosed microclimates. [5]

HEATING, VENTILATING, AND AIR CONDITIONING (HVAC) SYSTEMS

With the turn of the twentieth century had come developments in air conditioning and building design, as well as the general replacement of gas flame lighting with cleaner electric lights. Filtering and humidifying of air in the whole gallery became possible in newer buildings (where the will to invest in, and maintain this expensive option existed). Humidity and temperature control were still quite limited, and older buildings would have to cope with existing methods of climate control.[6]

By the mid-thirties, new developments in motor and fan design, ductwork, air cooling and architecture were taking hold. New technologies became available

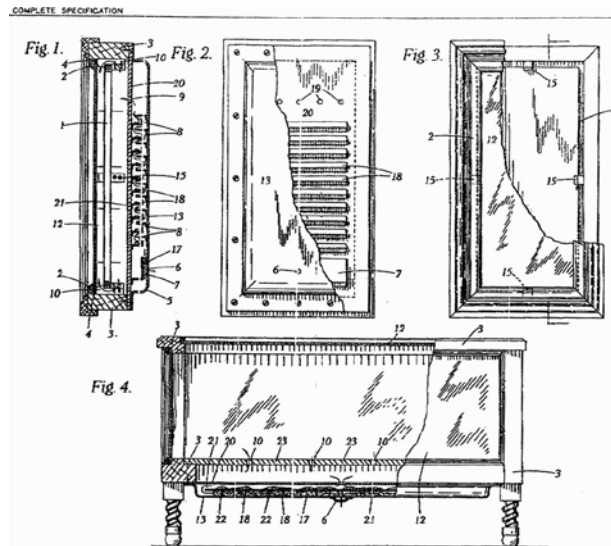

Figure 1. British Patent 396439, 1932 for a passive humidity controlled display case

for air conditioning galleries. Unfortunately, capital and operating costs for this kind of control were (and remain) very expensive. In addition, buildings must be especially designed to take advantage of these technologies, and very unpleasant conditions still may result when an older structure is retrofitted with newer building climate control technologies.

VENTILATED CASES

In a building using HVAC control, an artefact may need little more than protection from dust and curious or larcenous fingers. Indeed many display cases in the last century were designed to encourage the inflow of conditioned room air. However, air conditioned museums were in the minority, and in these museums a very limited range of environmental conditions could be maintained in each gallery. As some artefacts needed very particular, and different conditions for safe display, a leaky or ventilated case might not be suitable. Specialized microclimate enclosures would still be needed.

AN EARLY ACTIVE MICROCLIMATE ENCLOSURE

In 1938, a well-sealed display case with mechanical humidity control was built by Bill Young to create dryer than ambient conditions for an Egyptian bust in the Boston Museum of Fine Arts [7]. The gallery could not be controlled to the low humidities necessary to protect the object. Young's showcase used an electric pump (an advance then possible due to the nearly ubiquitous availability of electric power) to move air from the display case past an absorbent compound. With the simple addition of a motorized mechanism to control air flow to a substance that was usually



Figure 2. Electrically assisted passive humidity controlled display case, 1938

used as a passive buffer, humidity control could now be effectively provided in a sealed display case with a much larger volume than a picture frame.

The system was elegantly simple: The entire dehumidifying device was hidden in the plinth below the transparent glass case. Air was drawn from the case by a manually controlled electric pump and then forced through a bed of calcium chloride, removing much of the air's moisture before the air was re-injected into the upper display case. An interesting feature of the system was a gasometer, which moderated changes in barometric pressure. A similar method (diaphragm bags) is still used on some very tightly sealed cases.

SELF BUFFERING CASES AND MATERIALS

In some circumstances the materials and design of an enclosure create a self-buffering microclimate - the moisture exchange between air trapped in the enclosure and hygroscopic materials remains balanced. This is more common where the ratio of the volume of air to the buffering objects is relatively small and is often apparent in very small enclosures (e.g. a well-sealed picture frames) [8], in smaller display cases with generous amounts of cloth and wood surfaces, and occasionally in larger enclosures too (e.g. plaster walled dioramas filled

with stuffed animals and other moisture-holding materials).

SILICA GEL PASSIVE BUFFERS

An extension of the self-buffering concept is to provide a purpose-made buffering material that can be added to the showcase. A large number of organic materials could be used; over 1700 pounds of canvas hose was proposed for The Orangery of Hampton Court Palace in 1934 [6]. Inorganic silica gel offered many benefits, including seemingly infinite capacity for reuse. It was originally developed at the end of the First World War as a desiccant. In general use outside museums silica gel is usually first heated to remove moisture and is then used to capture and sequester humidity.

However, museum microclimate buffering uses silica gel's capacity to both retain and easily release moisture. This application uses a very small range of its moisture holding capacity, and regular silica gel is not very efficient as a buffering material. By varying the microscopic attributes of this material, silica gel can be tuned to form different grades, which provides more effective buffering in the range of normal museum storage humidities.

In display cases where leakage is well controlled and in an ambient environment where the average of year round humidities is close to the desired relative humidity, passive buffering can be very effective. A buffer in a case can absorb excess moisture as humid air leaks into the case and release it later when dry air leaks in. In theory, some buffers may never have to be changed. In environments where humidity conditions are consistently outside the desired target, larger quantities of buffering materials, frequent replacement, or tighter cases are needed.

By the nineteen seventies, silica gel had become a standard solution for case buffering and display cases could be ordered complete with drawers to hold a supply of silica gel for buffering [9].

While passive buffering using silica gel can be a vast improvement over cases with essentially no microclimate control, there are still significant areas where silica gel buffering proves ineffective. In some installations an inadequate transfer of moisture to and from the buffering compound into the case air results in stratification [10]. Air leakage through the case, and inadequate quantities of buffering materials can overwhelm the buffering capacity. Large cases can be especially vulnerable

to these effects. Monitoring and maintaining buffers can easily be overlooked, and is often neglected.

THE ARGUMENT FOR THE TIGHTLY SEALED CASE

A well-sealed case will substantially prolong the usefulness of a passive buffer, and more effectively block external airborne pollutants from entering the case. Museums began to look at sealed cases, air leakage testing, and other aspects of microclimate case control. In the final years of the last century, showcase manufacturers were encouraged by their clients to provide ever more tightly sealed showcases [11]. Metal and glass cases were now glued with silicone to prevent leaks, new case hardware was developed, and effective gaskets replaced brushes on doors. Display cases with leakage rates of one air change every ten days - an extraordinary achievement in sealing and design - quickly became commonplace.

THE ARGUMENT AGAINST THE TIGHTLY SEALED CASE

While providing new levels of protection for museum objects, tightly-sealed cases also pose new threats. Complex hinging mechanisms and very effective gasketing provide extraordinary seals, but the slightest misalignment of a door or the smallest damage to a gasket can substantially change a case's leakage characteristics, especially when the original leakage rate is so low. Leaks make the enclosed microclimate far more difficult to control. If a display case is designed with provision for microclimate control based solely on the maintenance of excellent seals and minimal air exchange with the gallery, increased leakage can be a climate control challenge. Leakage testing is difficult when cases are occupied, and galleries are populated, and conservators have little time to wander the galleries.

POLLUTION REVISITED

Early on, conservators sometimes noted unusual odours in their cases, especially as the cases became more effectively sealed. Tests revealed that pollutants generated within the enclosure could sometimes be at least as dangerous as those coming in from the outside. The expansion of analytical techniques in the late twentieth century revealed even more families of deleterious chemicals and measured these chemicals in smaller concentrations. A well-sealed case will not



Figure 3. Trapped pollutants create pattern on glass

only maintain relative humidity levels, it may also retain high levels of dangerous pollutants.

By the mid nineteen seventies, a number of conservators were investigating the effects of pollution in display and storage cases and were demonstrating the importance of maintaining a microclimate with very low levels of pollutants. Passive sinks for these pollutants had been suggested in the late sixties. By the mid-eighties The Metropolitan Museum in New York had created simple active microclimate pollution control units consisting of air pumps to force air through a pollution filtering canister before introducing the filtered air into display cases [9], displacing any pollution-laden air. Variations of this system were subsequently used again at the Met, as well as at the British Museum.

THE EVOLUTION OF ACTIVE MICROCLIMATE CONTROL MACHINES

As demonstrated by the use of various pump-assisted units, the concept of supplying conditioned air to cases was a viable solution for microclimate control, given appropriate technology. A number of attempts were made to adapt or apply building HVAC systems to supply conditioned air to display cases. In most applications it did not prove to be an appropriate solution. Eventually engineers realized that using whole gallery HVAC machinery for showcases was an approach akin to mounting a steam engine on a motorcycle. HVAC components were inherently too large, and fine control of their relatively massive output was fraught with problems.

An HVAC system is designed to control both temperature and humidity, but conservators realized that control of humidity levels alone would be their most useful application. Many chemical reactions can proceed only with the presence of water vapour, and while fluctuating temperatures might be directly deleterious to some materials, it was clear that the relative humidity swings occurring as a result of temperature variations created a more immediate danger, especially to composite and organic materials. Besides, building temperature control was generally a well-developed technology, and as heat travels fairly readily into and out of cases, maintaining consistent gallery temperature conditions generally proved easy and adequate.

Small commercial climate control units, especially made for room applications, did work, to varying degrees. In 1968 these small dehumidifiers were used at the British Museum to prevent bronze disease [12]. In other applications, humidifiers incorporating in-case humidistats were installed and later the British Museum would successfully use a combined humidifier and dehumidifier to treat a single case [13]. This pioneering work would eventually lead to a commitment to using active microclimate control devices throughout the museum. In the late sixties, the challenge of finding an appropriate technology remained.

THE SEDUCTIVE CALL OF MICROCLIMATES

The results from the early attempts at mechanical microclimate humidity control were more than just promising - they were tantalizing. Mechanical control of the microenvironment would allow display and storage case environments to be maintained at optimum conditions, regardless of ambient relative humidity. A reactive system would adjust relative humidity levels regardless of temperature changes. There would be no buffering medium to monitor or recondition, and the systems would also remove pollution. Dust and airborne pollutants could be kept out of the cases using positive pressure systems. Individual showcases could be controlled to provide optimum environmental conditions for their contents. Even in times of relatively cheap energy, the potential savings in HVAC costs were obvious and attractive. [14] The greatest portion of operating cost for most HVAC systems is humidity control, and with microclimate cases, tight control on gallery spaces would not be necessary (1). By the late nineteen-seventies, interest in active microclimate control was running high.

ATTEMPTS AT EMPLOYING BUILDING HVAC SYSTEMS

A number of attempts were made to harness the output of full size HVAC systems to display cases. Stories of showers of chipboard particles inside showcases [15], delicate pages fluttering [11], and condensation appearing on the interior of cases [16] continue to reverberate in the conservation community. An optimal solution continued to elude conservators and engineers - HVAC systems were too big to control, and more than a little dangerous to sensitive artefacts.

IN SEARCH OF THE BLACK BOX

In February of 1978, the conservation department of the Royal Ontario Museum in Toronto, Canada, organized a workshop called "In Search of the Black Box" [17]. Faced with an early twentieth-century building that could not be effectively controlled to modern museum standards, the workshop was called to discuss a variety of approaches towards protecting the museum's collections on display. Amongst the topics discussed was the provision of independent mechanical solutions for display case microclimate control.

A local engineering firm was engaged to create a microclimate device suitable for the museum, with the promise of a purchase if their research proved successful. In 1984 the first production models of the Micro Climate Generator were delivered. Using not compressors, but Peltier cells to provide cooling for the mechanism, these units were miniscule when compared to building HVAC systems, or even residential models. They provided unusually steady relative humidity levels in the showcases by using a proprietary humidity modification system and delivered a stream of air at constant (target) relative humidity.

HUMIDITY CONTROL BY DISPLACEMENT VERSUS ADDITION

In the common HVAC approach to humidity control, an influx of moist or dry air is occasionally added to a body of air to modify its relative humidity. The moisture content of the air rises or falls until the target has been met, and usually decays again, often resulting in repeated spikes in relative humidity. This spiking effect can become especially pronounced in small, sealed enclosures. The Micro Climate Generator used a novel approach: a steady

flow of air at the desired target humidity was injected into the case, continually displacing the existing microclimate. The recirculating flow of target humidity air was delivered at a rate often far greater than the case leakage rate. This rate of flow ensured that the case environment would remain at the desired humidity level, without overshooting or spikes.

As temperatures in the Royal Ontario Museum were relatively stable year round, the 1984 Microclimate Technology units were designed to provide a constant humidity level at a single target temperature. Soon, conservators at the Louvre pointed out that many museums did not have the luxury of well-controlled heating. In 1994 a new generation MicroClimate Generator, capable of responding to changes in ambient temperature, with advanced electronic controls and a DOS computer interface was introduced.

OTHER MINIATURE SYSTEMS

The MicroClimate Generator was not the only miniature device produced in the eighties. Others were produced in both the USA and Europe. All these small units used a constantly running fan or pump, but most modified case humidity by using the HVAC approach of intermittent humidification and dehumidification cycles. One of the simplest was the Artifact Preservation System (APS) in the early 1990's. The APS unit consisted of an oblong metal box containing both a bag of very dry desiccant and a wet pad as source of moisture. Computer fans, flap valves, and a mechanical humidistat controlled the mechanism. Air moved through 100 mm ducting, but the APS could be fit beneath many display cases. One of these units installed in 1995 in Bowdoin College, Maine, is still operating effectively [17].

In 1993 the MiniClima was introduced, using an electronic dehumidifier. Within the MiniClima was a small water tray set beneath an array of vertical aluminium fins in the air stream of a constantly running circulating fan. An electronic controller was connected to a sensor in the display case. When the case humidity exceeded pre-set upper or lower limits, the controller energized the appropriate mechanism. When the air in the case became drier than the lower limit, water from a reservoir was pumped into the tray, and evaporated directly into the air feed to the case. When the air in the case became too humid, an electronic cooling cell (Peltier cell) attached to the aluminium fins condensed water out of the same air feed, lowering its humidity. Condensation was collected in the tray and pumped into the reservoir.

Glasbau Hahn's active climate control system was generally only available with the purchase of their display cases. This humidity control device used a miniature pump, not a fan, to generate enough air pressure to move the air through the mechanism. Air was humidified in a chamber, and then passed over a Peltier cell cooled surface to reduce a moist flow of air to a suitable humidity. A constant flow of positive pressure air was fed to the cases through small tubes. Air injected into the case displaced case air, which was forced out of the case through leaks in the gaskets under very low pressure. In some applications, a single unit could be outfitted with multiple hoses, to deliver air to a number of showcases (to maintain similar humidities, all showcases had to be in the same temperature). The one way flow meant that no return hose was needed, but the amount of air that could be delivered by pump and narrow hose was relatively small. The recommended flow to control a case was less than one air change per day, necessitating the use of very well sealed cases and doing little to purge pollutants generated within the cases.

LARGE SCALE DISPLAY CASE MICROCLIMATE CONTROL

As we have seen, the application of large scale microclimate control for showcases was a temptation for generations of engineers. Mechanisms for room scale humidity control were well developed, but their application to museum cases needed some novel thinking.

Stephan Michalski of the Canadian Conservation Institute (CCI) published plans for a centrally located microclimate unit in 1982 [18]. This device provided a substantial one-way positive pressure flow of conditioned air to many cases. As in most other units, the "Ottawa Machine" used an additive system, switching between drying and humidifying modes to create appropriate humidity levels. Rather than dry the air by condensing water on a cold surface, the CCI unit used a commercial desiccant drying wheel to dry the air. To prevent transmission of the inevitable spikes from the drying and humidifying mechanisms, the Ottawa unit used a novel configuration of silica gel to buffer the output. By using this in-line moderator, the unit was able to produce a stream of air at constant relative humidity.(2)

The output from the CCI units was prodigious. Not only could many cases be controlled from one machine, the filtered air supply was ample enough

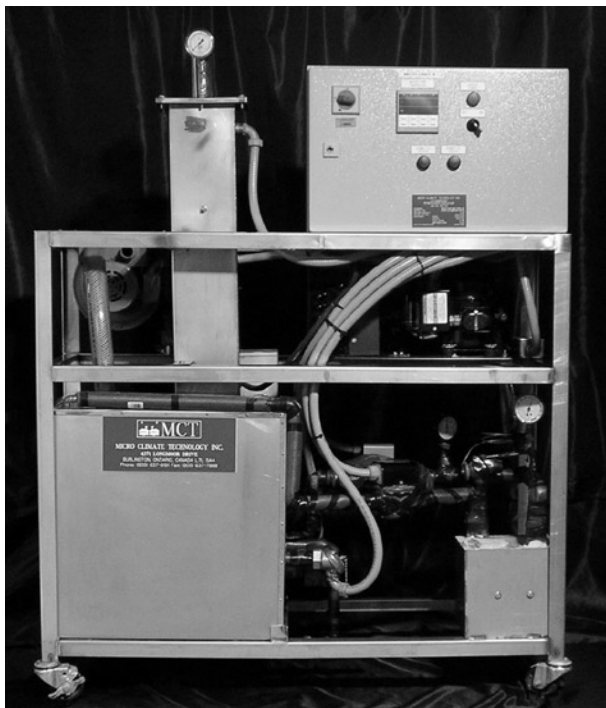

Figure 4. An early constant volume generator for positive pressure delivery, 1994

to effectively flush pollutants from within the cases. More than twenty units were built in the 1980's from the CCI design by Kennedy-Trimnell Inc., and used successfully in a number of North American applications [19]. The buffered moderating system was used again in an improved design published by CCI over a decade later.

In 1994 Microclimate Technologies introduced the first of a long series of large environmental control units, originally called the Constant Volume Generator (CVG). Unlike systems that combined separate humidifier and dehumidifier modules, these units utilised the same approach as their miniature units, using a single mechanism to provide a constant humidity output. As the units incorporated powerful blowers, they could be located hundreds of meters from the galleries. These positive pressure air distribution systems could feed many showcases at exchange rates of more than four air changes per day. A constant flow of clean air would also dilute and expel pollutants. No exhaust port was needed, as it was quickly discovered that no sealed museum case would contain air under pressure, and the oft predicted build up of internal case pressure did not occur.

The first installations of the CVG units at the Royal Ontario Museum, along with the success of the Ottawa Machines at the Museum of Fine Arts in Boston, the Field Museum in Chicago [20], and many other installations, proved the effectiveness

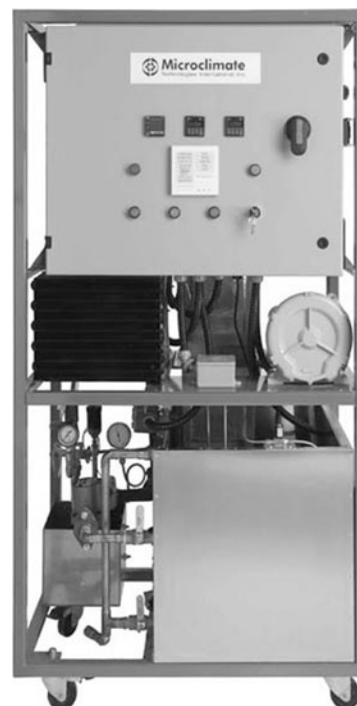

Figure 5. Recent model of a remote positive pressure unit, 2005

of the central unit approach. In Ottawa, a second generation of CCI units installed at the Canada Science and Technology Museum included many improvements.

The Microclimate Technologies' CVG unit developed rapidly, based on continuing feedback from a large number of commercial installations. New generations of the CVG units (now known as the MCG 30) were fitted with multi-point self-diagnostic systems and isolation valves in the air distribution system to dump supply air to the gallery and seal off enclosures in the event of the humidity stream going out of range. They had better pollution filtering, improved sensor systems, and other failsafes and innovations, resulting in more effective and reliable units.

OTHER MICROCLIMATE GENERATORS

A wide variety of units for display case environmental control have been built over the years, usually as unique systems. Many seem to have been effective, but few have been commercially viable. For example, the Royal Ontario Museum had a central unit that used alternately regenerating silica gel desiccant filters to reliably create a flow of very dry air. When it eventually wore out, it was replaced with a more conventional, commercially available microclimate system. Temperature control using electronic cooling was successfully applied in the early 1980's for very small scale applications [22], but the expense of

applying cooling technology has kept cooled cases rare (3).

LOW OXYGEN

In the early nineteen eighties, conservation scientists explored systems to remove oxygen from storage environments. Originally developed for the food industry, oxygen absorbers as well as inert gas purge systems were soon tested and applied by conservation scientists to the poison-free eradication of insects, as well as for the storage of organic and oxygen-sensitive materials. By 2000 both active and passive systems for oxygen-free display had been developed, tested, and installed, with varying success. Oxygen-free display and storage of museum objects still remains complex and rarely used. Continuing research in oxygen-free environments, as well as technical developments, cost reductions for nitrogen generators, ongoing exploration of the advantages of oxygen-free storage, and high profile projects (4) promise to change this.

STATE-OF-THE-ART SYSTEMS

The ultimate state-of-the-art active microclimate control system would be capable of supplying a dust, pollution, and oxygen-free, humidity and temperature controlled environment. While current technology can do it all, the cost is still substantially higher than simply controlling the humidity. However, complete environmental control is more than most applications will need - often the removal of only one factor will provide a relatively safe microclimate. In many cases, a simple (passive or active) microclimate control system providing constant humidity with some pollution control is adequate protection.

Many businesses now exist to serve the microclimate needs of preventive conservation in modern museums. Showcase makers routinely provide secure, low leakage cases. Engineers continue to improve their microclimate environmental control devices. Silica gel manufacturers have developed new and more efficient formulations. Specialized display lighting developers experiment with new light sources and technologies, and conservation scientists continue to develop new tests for known threats, find previously unknown threats, and assiduously study currently accepted methods for flaws.

All this sometimes frenetic activity is dependent on a long-standing basic human desire to define certain objects as special, and keep them for study

or veneration. In this, we differ from our ancestors only in the level of science and technology now available. Our efforts may seem primitive three thousand years from now, but our responsibility remains the development and perfection of methods for ensuring the long-term stability for the objects that our society considers extraordinary.

ACKNOWLEDGEMENTS

I would like to thank the many generous people who have written articles, sent emails, or simply taken the time to share stories from their past. I would appreciate any further anecdotes or shards of memories - this history is ongoing.

AUTHOR

Jerry Shiner
Microclimate Technologies International
jshiner@keepsafe.ca

REFERENCES:

- 1 British Patent 6556 (1892), referred to by S Edmunds in *Conservation Today* (1988) 50-53
- 2 Townsend, Joyce H. 2006. Personal Communication. Senior Conservation Scientist, Tate Britain, London
- 3 British Patent 396.439 (1933) referred to by LW Burrige in *Journal of the Institute of Heating and Ventilation Engineers*, 1935, 132-134.
- 4 Cursiter, Stanley. *The Control of Humidity in Controlled Spaces*, *Museums Journal*, 1936 44-45
- 5 Creahan, Julie *Controlling Relative Humidity with Saturated Calcium Nitrate Solutions* *WAAC Newsletter* 13 (1991); 17-18
- 6 JP Brown and William B Rose. *Development of Humidity Recommendations in Museums and Moisture Control in Buildings*. Full text at: <http://palimpsest.stanford.edu/byauth/brownjp/humidity1997.html>
- 7 Young, Bill, 1938. Copies of his original notes courtesy of Will Jeffers, Boston Museum of Fine Arts, 2006. The showcase was featured in *Edison News* 2, 1941 centerfold section (Boston?)
- 8 Sozzani, Laurent S., *An Economical Design for a Microclimate Vitrine for Paintings Using the Picture Frame as the Primary Housing* *Journal of the American Institute for Conservation* 36 (1997); 95-107
- 9 Weintraub, Steven 2007. Personal Communication.

- 10 Buttlar, Carolyn 2007, National Museum of Wales. presented in The History of the Showcase, *Conservation Matters in Wales: On Display: Showcases and Enclosures* ' A Conference on Museum Microclimates, Cardiff, Wales June 14, 2007
- 11 Hahn, Til 2007. Personal Communication. President, Glasbau Hahn
- 12 Bradley, Susan 2005. Preventive Conservation Research and Practice at the British Museum *Journal of the American Institute for Conservation* 44 (2005); 159-173
- 13 Bradley, Susan 2004. Personal Communication. Head of Conservation Science, The British Museum
- 14 Bishop, Rob 2006. Energy Use Impacts of Te Papa Relative Humidity Setpoints <http://microclimate.ca/articles/te%20papa%20savings.pdf>
- 15 Josephson, Dana 2006. Personal Communication. The Bodleian Library, Oxford
- 16 Calver, Andrew 2005. Personal Communication. Head of Conservation, Museum of London
- 17 In Search of the Black Box – A Report on the Proceedings of a Workshop on Micro-Climates Held at the Royal Ontario Museum, February 1978
- 18 Maschino, David 2006. Personal Communication. Exhibit Coordinator, Peary-MacMillan Arctic Museum, Bowdoin College, Maine
- 19 Michalski, Stephan. A Control Module for Relative Humidity in Display Cases *IIC, Washington Conference* (1982); 28-31
- 20 Kennedy, Sarah, 2005. Personal Communication. Partner, Kennedy-Trimnell Inc.
- 21 Sease, Catherine. The Development of the Humidity Control Module at Field Museum *Journal of the American Institute for Conservation* 30 (1991); 187-196
- 22 Padfield, T, Burke, M and Erhardt, D, A cooled display case for George Washington's commission, *ICOM Preprint, committee for conservation, Copenhagen* (1984) pp38-42.

NOTES

- (1) Much of the energy used to heat or cool the air in a building can be retained by heat exchangers when stale air is exhausted and fresh air brought. However, most of the very high energy cost of evaporating or condensing water to control relative humidity is lost with the exhausted stale air.

- (2) The CCI unit was an interesting hybrid, using an HVAC (addition-style) microclimate control mechanism to condition a silica gel buffer and then force air through the buffer to the cases. A variation of this method was used with the environmental control mechanism for the Mona Lisa in 2005, where a small microclimate generator reconditions a box of silica gel, and a fan then circulates air through the box and into the artefact case.
- (3) A temperature and humidity controlled display case was installed in 1997 in the Thomas Jefferson Building of the Library of Congress. The case is 12 feet long by 10 feet high and weighs 3 tons. It consists of a steel display chamber within an exterior of maple veneer with mahogany inlays. On either side, two large viewing windows are glazed with a specially rated ballistics polycarbonate and glass laminate. Small electronic microclimate cooling units, designed for mitigation of temperature swings, rather than complete control of temperature are now available. However, questions of expense, noise, energy consumption, and what to do with the transferred and waste heat continue to challenge both engineer and registrar.
- (4) Using techniques based on the encapsulation of America's Constitution, the Library of Congress will shortly have placed their copy of the Waldseemuller map, known as "America's Birth Certificate" in a very large oxygen-free enclosure. The back and sides of the case were milled from a single large block of aluminum.



This work is licensed under a Creative Commons Attribution - Noncommercial - No Derivative Works 3.0 Licence.

THE GOOD, THE BAD AND THE FRUSTRATING: DESIGNING AND IMPLEMENTING A CLIMATE CONTROL SYSTEM AT THE ROYAL ONTARIO MUSEUM

HELEN COXON

ABSTRACT

The significant renovations and expansion currently in progress at the Royal Ontario Museum have provided the opportunity to take a fresh look at the provision of humidity-controlled air to display cases. The planning process began in 2002, and the first of the new galleries opened in December 2005. When the last of the galleries reopens, the building will comprise sections of architecture built at four different periods from the 1914 west wing to the new Michael J Lee-Chin Crystal. Though the four spaces are for the most part physically contiguous, each imposes its own constraints on the environmental conditions.

Arriving at the finished system has involved many steps, beginning with the assessment of the RH needs of the more than 19,000 objects destined for display in the new galleries. Planning the controlled cases and piping layouts has had to take into account the varying needs of the objects, the large volumes of some of the display enclosures, the power of the control systems in relation to the distance that the air must travel, and the leakage rate of the cases.

Achieving the desired results to date has required compromise, flexibility, and the ability to re-think processes in the face of the empirical evidence. This paper follows the course of the process from the ideals of the initial planning to the realities of the final implementation, and passes on some lessons learned the hard way, as Phase 2 of the expansion continues.



Figure 1. The Michael J Lee-Chin Crystal, Royal Ontario Museum, opened June 2, 2007



Figure 2. New Chinese Gallery, opened December 2005

INTRODUCTION

This is a case history, but very much a story still in progress. The Royal Ontario Museum (ROM) in Toronto is presently undergoing a massive renovation and expansion, with a signature design by Daniel Libeskind resulting in 28,000 m² of renovated and newly constructed space, allowing for the display of almost twice as much of the collections as could be seen before the project began.

Called RenROM (an abbreviation of Renaissance ROM), planning began in 2001. The first group of new galleries, housed in refurbished locations in the heritage building, opened in December 2005.

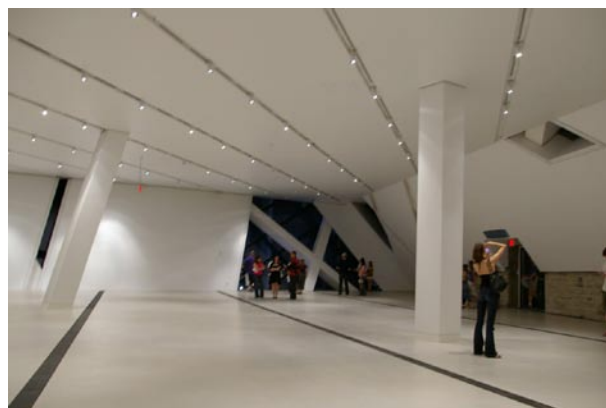

Figure 3. Future Phase 2 gallery space, prior to case construction

Phase 2 galleries, in the brand-new Michael J Lee-Chin Crystal, are scheduled to open in stages from November 2007 to March 2008.

Phase 3, which renovates the remainder of the heritage wings, is still further from completion. By the time the project ends in 2009 only one floor of one wing of the pre-2001 building will remain completely untouched and unchanged. However at the time of writing, less than half of the new galleries are open.

This is a story of the climate control challenges encountered in renovating an existing building, part of which is nearly 100 years old, and the problems introduced by the architectural design of the new expansion: iconic, striking, and decidedly non-traditional. At the end of the RenROM project, we will have a composite building dating from four different periods over the past 100 years – 1914, 1933, 1984, and 2007.

The ROM galleries experience a wide annual fluctuation in RH; in some areas as much as 50% change from a winter low of 25%, (when the risk of damage to the fabric of the older parts of the building make it inadvisable to humidify to a higher level), to a summer high of 70% or more. RH specifications for the new part of the building, known as the Michael J Lee-Chin Crystal, call for a level of 45% \pm 5% year-round, though it is hard to see how this can be reliably maintained, since the Crystal is not an isolated space. Every level of the Crystal has walkways to the older wings, and though some of these links have doors separating the old building from the new, the walkways are also open from floor to floor. The Spirit House, as the central spine of the Crystal is known, forms a void, open from the ground floor up to the fourth floor.

Given that some degree of humidity control is necessary to mitigate the extremes of the range for the most sensitive artefacts, the choice was between refitting whole gallery spaces to permit better control of ambient conditions, and controlling the individual cases. Our preference would have been for control at the gallery level, but in the older parts of the building the relative cost of renovating gallery spaces versus that for installing humidity control systems for limited numbers of display cases dictated that the existing space was upgraded in only one gallery area, principally to permit the display of organic materials without case enclosures. It is anticipated that the ambient humidity in the new Crystal galleries will be more stable than in the older wings, but we are nevertheless installing humidity control systems

in the art and archaeology galleries regardless of whether they are in the old or new sections.

PAST PRACTICE IN RH CONTROL AT THE ROM

Mechanical control of RH within display cases (as opposed to the passive use of silica gel), has been in place at the ROM since 1985, when small micro-climate generators (MCG) were first introduced to the galleries. These small machines recirculate air within the case, adding or removing moisture as necessary. Control is provided by a sensor located within the display volume. The capacity of these machines, up to about 17 m³, depending on the leakage rate of the display case, is such that in most instances one machine controls only one case volume. Their great advantage is that the RH levels can be set individually for each machine and therefore each display case.

Around 1995, a larger version of the MCG was developed by the same company [1]. Not only were the new units capable of controlling multiple cases, rather than just one or perhaps two, but they were also attached directly to the water supply, thereby removing the need for manual refilling or draining of water reservoirs every week. Each of the new machines was capable of controlling more than 100 m³ of display volume. In addition, they did not recirculate air taken from the display cases, but drew their intake from the room in which they were housed, creating a slight positive pressure within the cases, which were therefore less affected by leakage. To the extent that there were drawbacks, they were that all the cases supplied by one machine had necessarily the same RH level, which inevitably reduced flexibility.

DESIGNING FOR RENROM

Each method of RH control employed thus far has had some drawbacks and limitations: the use of silica gel is labour intensive, and only really effective in relatively small, airtight display cases. The small MCGs were rendered less effective by case leakage and also required significant staff time manually to fill or drain the water reservoirs every week. The use of larger MCGs to supply multiple cases was in some ways more limiting than the smaller versions, which could be individually set.

RenROM seemed to be the perfect opportunity to implement a climate control system that would deal with some of the limitations of earlier control methods, and more fully meet the needs

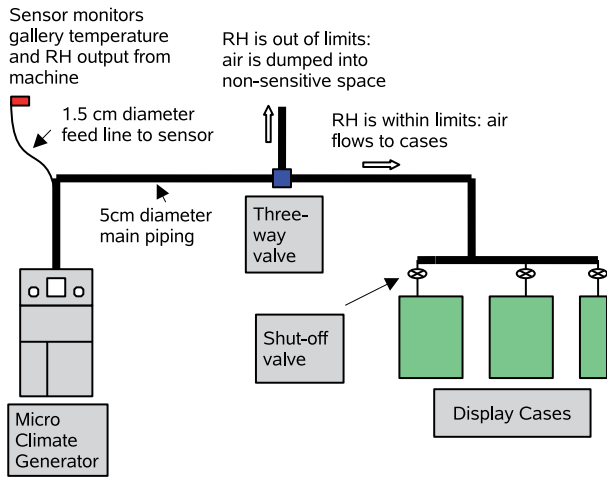

Figure 4. Schematic of MCG and piping to display cases

of the objects. The project team had agreed to the installation of climate control systems where specified by Conservation, the exhibit designers professed themselves prepared to work with us to provide the best possible conditions, and display cases from Glasbau Hahn promised a suitably low air exchange rate.

Research on possible control systems revealed nothing that seemed preferable to the newest designs from the manufacturer of our present systems. Their new generations of MCGs are ever more sophisticated. In the early versions one simply set the required RH level or dewpoint, and let the machine run. Variations in temperature within the display volume, usually caused by case lighting, resulted in unstable RH levels, and in variations from case to case. In addition, in the absence of a proper alarm system, faults in the machine resulting in humidity levels outside the acceptable range might go unnoticed for hours or even days.

In the latest generation of the machine, the MCG 40, a sensor located in the gallery space monitors the RH output from the machine and the ambient temperature, and allows the MCG to adjust its output to maintain a stable RH level even with fluctuating temperatures. This is an advance on the earlier



Figure 5. Two MCG 40s serving the Japan Gallery. On the closer machine can be seen the air filter (white grille), ion exchange cylinder and protective three-way valve (black unit on top of the machine)

systems, but still not a completely satisfactory situation, since it means one must assume (a) that the temperature is constant throughout the gallery, and (b) that the temperature is the same in all display cases serviced by the same machine, since the sensor does not monitor individual case interiors.

The same sensor, coupled to a three-way valve, also provides critical fail-safe protection for the artefacts in the cases. So long as the supplied RH falls within the set limits, air flows to the cases. If the RH deviates from the acceptable range, the valve rotates to block the air flow to the cases, routing it instead into a non-sensitive space such as a mechanical equipment room, until such time as the RH of the supply air is restored to acceptable levels. Thus in the event of mechanical failure of a machine, or a power interruption followed by a restart, the displays are protected from the

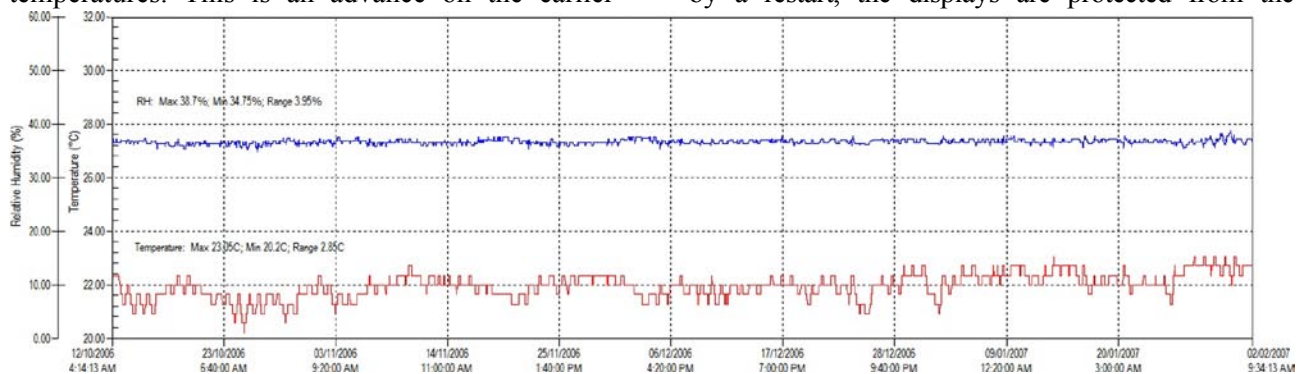

Figure 6. Sample datalogger chart from a display case in the China gallery

possibility of a dangerously high level of humidity being pumped into the cases while the machine is working towards achieving the set RH value.

The MCGs also improve the quality of the air being pumped into the display case. Incoming air is filtered at the machine intake to eliminate dust and contaminants, and the water supply is purified by a combination of reverse osmosis and ion exchange. The majority of the display cases containing RH-sensitive material in the new galleries are now controlled by these MCGs.

The Phase 1 galleries have been open for nearly two years now, and the results from the humidity control are in general very acceptable. The RH within the cases is extremely stable, varying by at most a couple of percent.

Even the handful of cases still using silica gel because they were too small or too inaccessible to run piping are extremely stable. However, reaching that point of acceptability has not been without its frustrations and difficulties. The issues that we have encountered so far, and will continue to encounter as the project progresses, result from several causes.

ARTEFACT CONSIDERATIONS

The ROM is a general museum, with collections in art and archaeology and the natural sciences, though almost all the need for RH control is on the material history side. Setting humidity levels for display is most easily accomplished where a display case houses materials of a like nature, requiring the same optimum RH level. However, in a museum with mixed collections, the storyline and design favoured by curators rarely allows for this neat separation of materials, and some compromise is necessary.

Given budgetary and space constraints, for most of our RenROM display cases there has been a choice of at most two generated RH levels as alternatives to ambient RH. In many areas of the old galleries, which feature relatively small display cases, we have indeed been able to separate organic materials from metals in order to provide each type of material with the optimum RH range and the new China and Japan galleries, for example, have display cases maintained at 30%, 40%, or 50% RH, depending on contents. In contrast, a major feature of the Crystal galleries has been the large volume of some of the display cases, which has required a different approach to RH control. The storyline created by curators and designers, and the sheer case



Figure 7. Large display case in Canada's First Peoples Gallery. Some cases in the Gallery of Africa, Americas and Asia Pacific will be larger still

size, necessitates mixing materials, and therefore imposing a compromise RH. So in the Canadian First Peoples gallery, all controlled cases are supplied with 40% RH, as a compromise between the lower value desired by the metals conservator, and the higher value desired for organic materials.

Achieving the best possible environment for as much of the displayed material as possible has involved negotiation, the provision of sealed partitions in cases, silica gel control for some small-volume cases, and substitution, or even removal, of certain artefacts from the final selection for display.

PIPING AND AIRFLOW FACTORS

The next major issue to be faced resulted from the design of the new building, and the sheer size and scope of the renovation. The current MCGs are designed to provide a constant 700 l/min air supply at the output point. Depending on the configuration of cases and piping, this is sufficient to control up to 170 m³ of display case at a leakage rate of 4 air changes per day (acd). Display cases for the new galleries are designed and installed by Glasbau Hahn to a specification of 0.1 acd for an uncontrolled case, and 0.3 acd for a case supplied with conditioned air. The larger leakage rate is designed to avoid possible over-pressure of the controlled cases by permitting a small amount of leakage. In fact, that leakage rate has proved to be still too airtight for controlled cases under positive pressure; in setting up the systems in the Phase 1 galleries, we found that large cases could require as much as a week to establish the specified RH level. Future modifications will insert a relief valve to permit flushing of the case volume when RH levels need to be established or re-established quickly. However, on the plus side, an undisturbed display case can hold its RH level for at least a similar length

of time, permitting shutdown and maintenance of the machines without adversely affecting the cases.

Though the cases are sufficiently airtight that they require only a very low airflow to maintain the required RH level, some of our largest display cases are between 60 and 120 m³, which clearly drastically reduces the number of cases that can be controlled by any one machine. Also to be taken into account is the distance the air has to travel to reach the display case. According to the manufacturers' specifications, the nominal maximum distance from machine to the furthest display case is 160 m in a straight line. Every time the piping must undergo a change in direction in its course from MCG to display case, the airflow is diminished, and so, potentially, is the total controllable volume. Thus, though simple mathematics would seem to show that a much greater volume can be controlled at 0.3 acd than at 4 acd, the reality is less straightforward.

The situation is acceptable in the heritage wings, in which the machines are almost all physically located adjacent to the gallery space, and the furthest distance from machine to case is perhaps 60 m on the same level of the building. However, in the Crystal, the gallery design does not allow for mechanical room spaces next to the galleries, and so all the MCGs will be located in one space in the basement. Since some of the galleries are on the third floor, the humidified air must travel large distances from the generating machine before it reaches the gallery level at all, let alone the display cases. The flow of conditioned air is further affected by the angled walls of the Michael Lee-Chin Crystal, and in designing the main piping runs, insufficient attention was given by the engineers to minimising direction changes in order to provide the maximum airflow. Tracing the path of the main piping is not easy, but even a cursory inspection shows that the piping makes four or five ninety-degree turns before it rises up the face of the Crystal, and up on the third floor it appears to make at least five more right angle turns in three dimensions before heading off into the gallery. Not only is the distance to reach the furthest case in the South Asia gallery quite considerable, but the airflow will be substantially reduced by the number of angles in the piping run. The combination of volume and distance seems set to push to the limit the theoretical capacity of the MCGs supplying the Crystal galleries.

There is one further concern relating to the supply piping: accessibility for maintenance or modifications. In the heritage galleries the piping

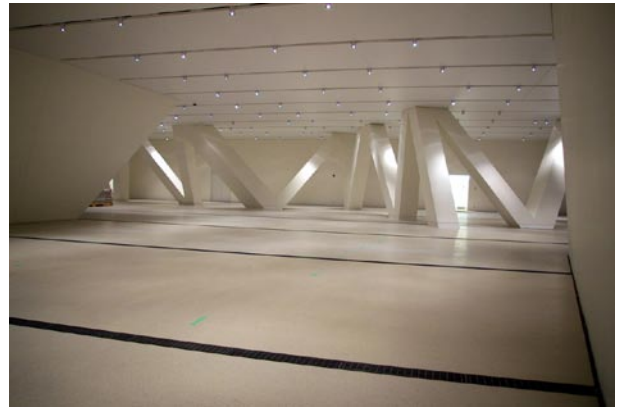

Figure 8. Garfield Weston Exhibit Hall, showing HVAC air supply grilles in the floor

runs in open cable trays above the cases, and drops down to a specially designed flow valve. In addition there are shut off valves for each case so that they can be isolated from the main run. Adjustments are easily performed. In the Crystal, all the services run below the floor, sandwiched between layers of concrete, in a space which is actually the supply air plenum for the HVAC system. A series of grids runs at 16 ft intervals across the floors to allow air into the gallery, from where it is exhausted at ceiling level. The RH control piping runs through the plenum and comes out under the grid a foot or so outside the perimeter of the display cases, to allow access to the shut-off valve, before being routed under the case to come up through the case floor into the display volume. Not only is the piping much less accessible, it will also be heated in the winter and cooled in the summer by the HVAC system.

SENSOR CONSIDERATIONS

As described earlier, sensors located in gallery ambient conditions sample the air coming from the machines through a small-diameter pipe, and direct the MCG to adjust its output to compensate for temperature fluctuations. Resistance to airflow in the small pipe has been a significant concern in the Phase 1 galleries, in which the three-way valve is mounted directly on the machines. The air feed to the sensor must be led off the main piping before the position of the three-way valve, i.e. close to the machine output, (see Fig 4) and yet the sensor needs to be located somewhere representative of normal conditions in the gallery, probably at some distance from the MCG. The length of small diameter piping, and therefore the resistance to airflow can be considerable. In the Crystal galleries, where the distance from MCG to gallery is many times greater, such a configuration would be completely non-functional. In these circumstances the sensor and

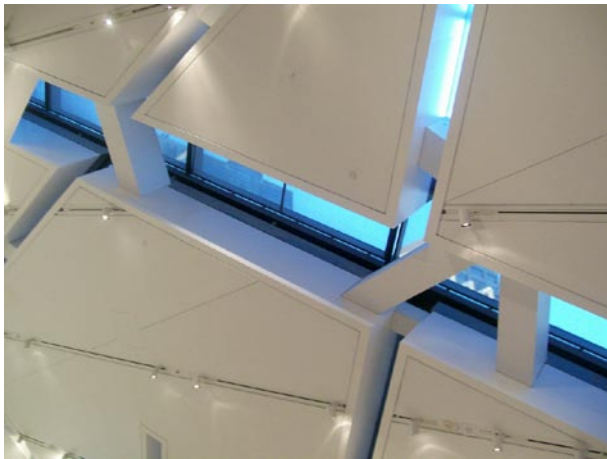

Figure 9. Narrow windows in Crystal gallery. Some windows have a larger open area, but they predominantly face north

three-way valve are both located in the gallery. At the time of writing the MCGs for the Crystal have not been installed and started up, and therefore there is no hard evidence, but in anticipation of difficulties in getting the conditioned air to both sensor and to the cases, all the new machines have been provided with a more powerful blower motor than is usual.

LIGHT AND HEAT FACTORS

The whole design concept for RenROM has centred around openness and light, and as planning began, it was evident that a significant proportion of the Crystal construction was intended to be clear glass. In addition, the plan called for the uncovering of the west-facing windows in the west wing, which had been blacked-out for many years. Despite extensive computer modeling of changes in sunlight through an annual cycle, it seemed unlikely that it would be possible to keep light entering from outside to a level low enough for light-sensitive materials. Furthermore, sunlight falling on a display case will cause a rise in temperature and a corresponding fall in RH.

So it has proved. In the Crystal, the situation is actually better than we originally anticipated. Much of the open window area faces north, and receives no direct sunlight, or illuminates galleries containing objects insensitive to light. In addition, the wall of the Crystal is extremely thick, so that light entering by the narrow windows is kept to a minimum. The major temporary exhibit space is below ground level and receives no natural light at all, while in the fourth floor rotating exhibit space, windows are blacked out as necessary.

In the older building, the west windows have been opened but conservation concerns have been partly met by locating light-sensitive materials, as far as the story-line permits, in display cases away from the windows. In addition, the windows are fitted with blinds which block 95 % of exterior light from entering. These are motorized, and in theory will respond to changing light intensity outside. In reality the amount of light falling on those windows is such that the blinds are always closed, and the motors inactivated.

However, even with the blinds down, we have recorded unacceptably high light intensities or “hot spots” in some areas at some times of the year, even in cases on the opposite side of the gallery from the windows, and modifications are currently underway to further decrease the amount of light entering the galleries.

COMMUNICATION FACTORS

One of the main lessons to be learned from our recent experience is that good communication is paramount between all parties and at all stages. I have barely touched on some of the problems we have faced, but several of them might have been lessened, and much frustration avoided, had there been better communication both internally, and with the MCG manufacturer, both in the planning and construction stages.

In the first stages of planning, a number of staff teams were created, tasked with evaluating the design and reporting back to the main design team on topics such as movement of collections around the building, access for exhibit installation, display case layout, visitor flow, etc. Initial plans were widely distributed, and comments were encouraged. However as time passed, it was noticeable that fewer plans were sent out, and at increasingly lengthy intervals. Within two years of the beginning of the project, these teams had ceased to meet, and significant changes in the plans occurred without notification to stakeholders.

In at least one instance, this lack of communication might have had (and may still have, since the Crystal galleries are not yet installed), a disastrous outcome. I discovered purely by chance, while talking to a contractor about something totally unrelated, that the plans called for the installation of under-floor heating at the outer edges of the Crystal galleries to compensate for any temperature drop close to the outer walls. By comparing floor plans, it was

possible to see that the heating grid would in some places run underneath parts of display cases.

The likely temperature difference between heated and unheated areas of the floor could be considerable, and might cause problems not only with the RH control within the cases, but also with the fabric of the cases themselves. A redesign has moved the perimeters of the heated area, but only experience, once the cases are constructed, will show whether there is still a problem to be resolved.

CONCLUSION

This has been a very limited look at just some of the hurdles to be overcome in setting up RH control systems in the 'new' ROM. For the Phase One galleries we have largely identified the difficulties in the system, and corrected or compensated for them, but for the Crystal galleries, though we can predict where some of the problems will occur, undoubtedly there are other unforeseen challenges to be found as we move towards the gallery opening dates. By the end of Phase 3 of RenROM there will be more than 25 large-volume MCGs in operation. The future seems certain to be interesting.

AUTHOR

Helen Coxon. Conservator,
Preventive Conservation,
Royal Ontario Museum, 100 Queen's Park,
Toronto, Ontario, Canada.
helenc@rom.on.ca

NOTES

1 Microclimate Technologies International Inc.,
5266 General Road, Unit 4, Mississauga, ON
CANADA L4W 1Z7



This work is licensed under a Creative Commons Attribution - Noncommercial - No Derivative Works 3.0 Licence.



The Nydam boat, a 4th century AD warship, was on temporary display at the National Museum of Denmark in the spring and summer of 2003. Its length prevented it entering the normal exhibition area. An inflated, climate controlled, tent-like structure was built for the boat in the courtyard of the museum.

